



BULL

AU SERIES

USER'S MANUAL

Minimum recommended operator age :16

WARNING

THIS VEHICLE CAN BE HAZARDOUS TO OPERATE. A collision or rollover can occur quickly, even during routine maneuvers such as turning and driving on hills or over obstacles, if you fail to take proper precautions.

SEVERE INJURY OR DEATH can result if you do not follow these instructions:

- **BEFORE YOU OPERATE THIS ATV, READ THIS OPERATOR'S GUIDE AND ALL ON-PRODUCT SAFETY LABELS.**
- **NEVER OPERATE THIS VEHICLE WITHOUT PROPER INSTRUCTIONS.** Complete a certified training course.
- **NEVER CARRY A PASSENGER.** You increase your risk of losing control if you carry a passenger.
- **NEVER OPERATE THIS VEHICLE ON A PAVED SURFACE.** You increase your risk of losing control if you operate this vehicle on pavement.
- **NEVER OPERATE THIS VEHICLE ON PUBLIC ROADS.** You can collide with another vehicle if you operate this vehicle on a public road.
- **ALWAYS WEAR AN APPROVED HELMET,** eye protection, and protective clothing.
- **NEVER RIDE UNDER THE INFLUENCE OF ALCOHOL OR DRUGS.** They slow reaction time and impair judgment.
- **NEVER OPERATE THIS VEHICLE AT EXCESSIVE SPEEDS.** You increase your risk of losing control if you operate this vehicle at speeds too fast for the terrain, visibility conditions, or your experience.
- **NEVER ATTEMPT WHEELIES, JUMPS, OR OTHER STUNTS.**

WARNING
Read the guide thoroughly & observe important safety information.
Always follow the age, height & weight restrictions.
Age 16 or older for AU2022.
Obey the Operator's Guide in the vehicle.



Important Information

Before riding, please read this user's manual carefully and take related training courses. Please follow tips for lowest age for the model. The manual contains plenty of important safety information and tips necessary for riding and maintenance. For your personal interests, please pay attention to the following notations:

 **WARNING**

—failure to follow the warning, you will result in serious injury or death.

 **CAUTION**

—failure to follow the caution, you and your vehicle can result in injury.

Please fill in your ATV information in the box below:

VIN:

Engine No.:

Dealer name:

Kayo has been dedicated to develop best products with advanced design and research methods, to help our customers enjoy the pleasure of outdoor sports physically and mentally.

Kayo persistently pursues good quality of products and reasonable cost control to realize Thank you for choosing and supporting Kayo. Kayo will spare no efforts to offer what fits your best.

Wish you a pleasant ride!

A handwritten signature in black ink, appearing to be 'Kayo' or similar, written in a cursive style.

This manual should be considered as a permanent part of the ATV and should remain with the ATV when it is resold.

This manual includes the latest production information available. Zhejiang Kayo Motor Co., Ltd. reserves the right to make changes at any time without notice and without incurring any obligation.

No part of this publication should be reproduced without permission of Zhejiang Kayo Motor Co., Ltd..

This vehicle pictured in this book may not match your actual vehicle due to product update.

Preface

Thank you for choosing our sports series ATV. We will do our uttermost to serve you and our products will bring you enjoyment.

Now you own a technically advanced utility type ATV from Kayo which is specially designed for riders above 16. Before riding, please read the user's manual carefully, especially the safety tips.

The information is intended to help you to avoid the damage to your vehicle, other property or the environment. As long as you maintain and use the vehicle as required by the manual book, the ATV will bring you lots of fun and enjoyment instead of unnecessary hurt.

We treat every customer seriously and appreciate each advice you put forward. For differences of demands from customers in different areas under various cultures, our products may have some disadvantages. Your suggestions for improvements and developing are welcome.

We treat every customer seriously and appreciate each advice you put forward. For differences of demands from customers in different areas under various cultures, our products may have some disadvantages. Your suggestions for improvements and developing are welcome.

Warranty Declaration

In the design and production of Kayo AU series ATV, the general and various complicated conditions are taken into consideration. It's crucial to maintain the vehicle especially the early use of engine and frame, to reduce wear and prolong service life based on the manual book. Improper adjustment to the vehicle may damage the parts, reduce safety and service life.

Warranty shall not cover the bikes which are modified without Kayo authorization or attached with spare parts which are not officially certified or don't fit the model. Warranty shall not cover the bikes which are not maintained based on the manual book or when no proper maintenance record cannot be provided. Warranty shall not cover the bikes which are broken due to improper operation or irregular use.

Notice: Above is general declaration. Please check with the local authorized distributor for detailed warranty period and information.

Age Recommendation

Lowest age for this ATV is 16 years old. Young children under 16 should not operate the vehicle.

Rider Training

All riders of this ATV should be guided properly.

KAYO utility type ATV —AU180



 **WARNING**

Kayo AU series models are utility vehicles, not suitable for high intensity professional racing.

Our company shall not incur the obligation when the rider uses the vehicle out of the range of application and cause breakdown and accident.

The rider should wear necessary defensive gears before riding.

The rider should inspect the vehicle to make sure its systems and components are in good condition before riding.

The rider is forbidden to ride after drinking alcohol or taking drug or narcotics.

CONTENTS

Vehicle Component Locations	2
Vehicle Parameter	3
Vehicle Mark Description	4
Control Functions	7
Loading Functions	9
ATV Riding Knowledge	10
ATV Safety Matters	12
Inspection and Maintenance	16
Troubleshooting	21
Unpacking and Dissemble	24
AU180 Electrical Circuit Diagram.....	25

AU180 Vehicle Component Locations



Vehicle Parameter

Model Parameter

Vehicle size and weight	
MODEL	AU180
Vehicle length	1680mm(66.1in)
Vehicle width	960mm(37.8 in)
Vehicle height	980mm(38.6 in)
Seat height	730mm(28.7 in)
Wheelbase	1050mm(41.3in)
Ground clearance	150mm(5.9 in)
Front wheel track	730mm(28.7 in)
Rear wheel track	735mm(28.9 in)
Vehicle weight	155kg

Engine Parameter

Engine parameter	
Engine model	R02-GY200-ATV
Engine type	Single cylinder, 4 stroke, air cooler
Displacement	177.3ml
Bore ×Stroke	62.5X57.8mm
Compression ratio	10:1
Max Power	9.1KW/7500±500r/min
Max Torque	10.0N.m/5500±500r/min
Ignition	C.D.I
Starting	electric

Vehicle Mark Description

Vehicle Information Coding

AU180



(1) VIN NO.



(2) ENGINE NO.

Warning Stickers and Position

General Warning Sticker



Age Warning Sticker

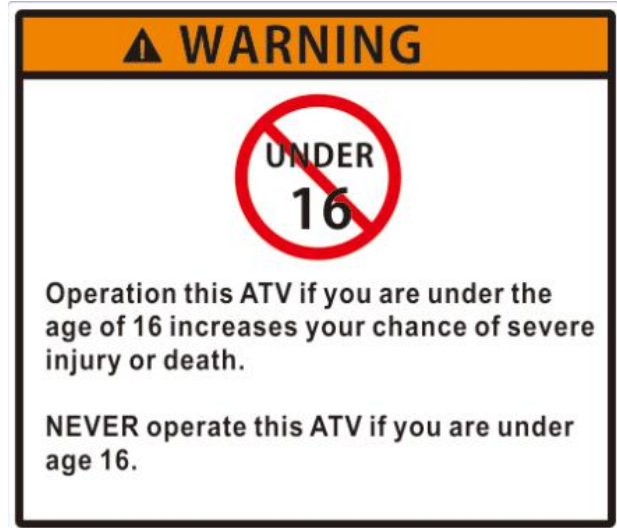

This warning sticker is put on the left front plastic, same as below picture.



Tyre Pressure and Overload Combined Warning Sticker

Passengers Warning Sticker



The above two warning stickers are put on the left rear fender, same as below picture.



Please observe the prompt content of warning labels, otherwise, it may cause property loss and even casualties. Please keep warning labels clear and complete. If warning labels are blurred or damaged, please contact the local distributor for new ones, and paste in the original position.

Control Functions

Handlebar&Switches

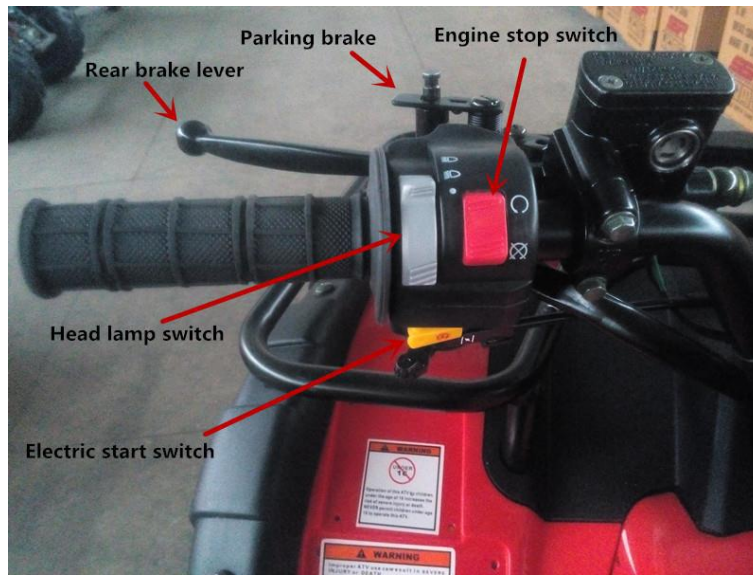

LEFT HANDLEBAR

Engine stop switch :

With the Engine stop switch on the left of handlebar in the “Stop” position, the engine cannot be started. With the Engine stop with in the 'RUN" position, the engine can be started.

Electric starting button:

With the key switch in the 'ON' position, pressing this button will automatically start the engine.

Parking brake:

Set the parking brake: grip the brake lever, press the parking brake pin, then set the parking brake.

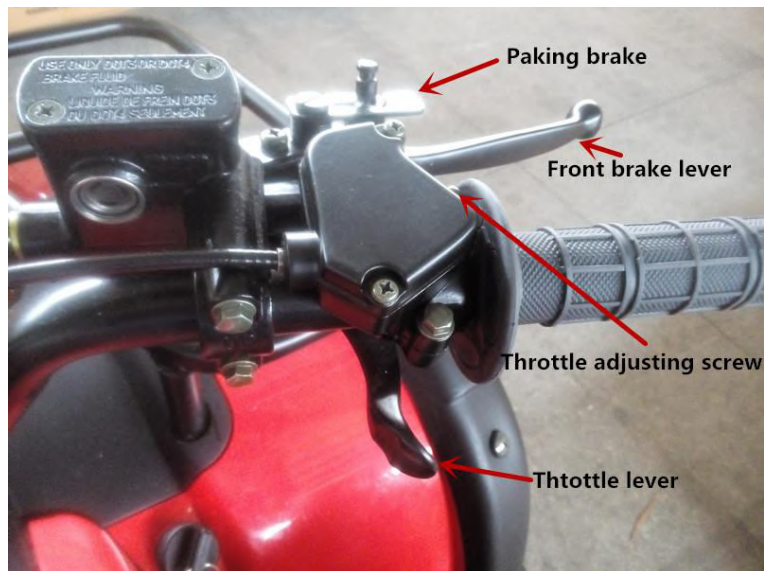

RIGHT HANDLEBAR

Throttle Lever

The throttle lever is used for controlling the engine and ATV speed. Operate this lever with your thumb. Push it forward to increase engine and ATV speed. Release it to decrease engine and ATV speed.

Parking Brake

To set parking brake, squeeze front brake lever, press parking brake pin, set the parking brake lever.

Throttle Limiter Screw

When controlling the throttle, you should screw in the adjusting screw.

Using the throttle limiter screw to restrict maximum speed of the ATV. Adjusting this limiter according to the rider's skill and experience.

Adjusting procedures:

1. Loosen the Lock nut.
2. Turn the throttle limiter screw clockwise to restrict maximum speed of the ATV.
3. Turn the throttle adjusting screw counterclockwise to increase the maximum speed of the ATV.
4. After adjusting, tighten the lock nut.

Fuel Tank Switch

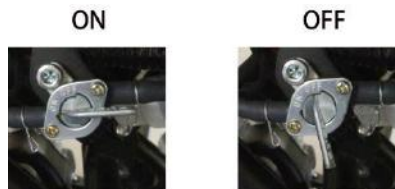

There are two positions: "ON", "OFF".

"ON" position - In this position, fuel will flow into the carburetor when the engine is running or being started.

"OFF" position-Fuel will not flow into the carburetor.

Fuel Tank Cap



To open the fuel tank cap, take the end of the vent tube out from the vehicle body, needing to turn the fuel tank cap counterclockwise. To close the fuel tank cap, turn in it clockwise and tighten it firmly. Be sure that the vent tube securely connects to the cap.

Loading Functions

As originally equipped, this ATV can carry cargo or tow a trailer, but please be sure to be accordance with your common sense and good judgment. Please note the following:

- Do not exceed the weight limit. An overloaded ATV can be unstable.

Maximum load (AU180):

Rear rack: 20 kg (44 lbs) front rack: 15 kg (33 lbs)

- When loading the cargo on the rack, it's better to be close to the vehicle center, that is, near the front of rear rack and the rear of front rack. Both sides of the rack should be best possible to share the goods. Goods should be fixed firmly to ensure not to damage to the carrier and not to move during riding.
- Overload moving could cause an accident.
- Ensure that the load would not interfere with your control of the ATV, and will not affect your sight.
- Control riding speed to be slower than the no-load speed. The heavier the loading is, the slower the speed will be.
- It needs a longer braking distance when loading, because the heavier vehicle takes longer time to stop.
- Avoid sharp turns, except in very slow speed.
- Avoid riding on hills and rough terrain. Please choose the terrain very carefully. ATV increased weight will affect the stability and handling.
- The cargo rack must not carry passengers.

ATV Riding Knowledge

What You Should Know Before Riding

1. Before riding, you should read all the following information carefully. Operating this ATV without reading instruction could be dangerous.
2. Beginners and inexperienced riders should take the complete training course .You should be well acquainted with skills learned in the course and practice the operating techniques described in this user's manual.
3. Before riding, you should find a good place to practice the skills, find a flat, open area with enough space to practice the new skills, make sure that it is legal to ride in the area you select, review the local laws and make sure you are not trespassing. When you are riding, please keep the terrain in good condition, do not destroy plants, trees or other vegetation, do not litter and affect the local animals.Only in this way, your riding area can remain for future use.
4. After you find a good place to practice, please review the control system on your ATV before riding, learn to find these controls without looking for switches, because you will not have time to look for them when you are riding. The risk of riding could increase greatly if you do not know how to operate the ATV properly under different situations and in different types of terrain.

If you are properly prepared, you will have a more enjoyable riding.

Inspect the ATV Before Riding:

Failure to inspect the ATV before operating could be hazardous. Failing to perform proper maintenance could also be hazardous. Failing to inspect and maintain your ATV could increase the chances of an accident or equipment damage. Always inspect your ATV each time before riding, and make sure it is in a safe operating condition.

ITEM TO CHECK	CONTENT
Steering	Smoothness; No restriction of movement; No play or looseness
Brakes	Proper damping return; Enough braking force; Effective braking performance
Tires	Proper air pressure; Enough tire pressure; No cracks and breaks or other damages
Fuel	Enough fuel for the expected trip; Fuel hose connected securely; No damage to fuel tank or cap; Fuel tank cap closed securely
Engine stop	Proper operation
Engine oil	Proper level - Check the oil by inspecting the Engine Oil Indicator located at the bottom of the engine. The engine oil should completely fill the view window. Add oil if the window is not completely filled.
Throttle	Proper and smooth throttle return; Smooth return on the idle position
Chain drive system	Proper tension; Adequate lubrication; No excessive wear or damage
General condition	Bolts and nuts are tight; No 'quack-quack' from any parts of the engine when running; No visible damage

WARNING !

1. Overloading could be hazardous! Overloading could cause changes in vehicle handling and could lead to an accident. It must not exceed the ATV rated loading.
2. Do not make any unnecessary changes on the ATV! Improper installation of accessories or modifications to this vehicle may cause changes in handling, which could lead to an accident.
3. Please do not use improper tires or improper tire air pressure. If you use improper tires or improper air pressure, you may lose control of the ATV, which will cause an accident.

Using the wedge to chock the ATV to avoid the mechanical problems, or the wedge can be used for ATV temporary stay during the riding. Before riding the ATV, be sure to check the above items. Be sure your ATV is in good condition of safe riding.

ATV Safety

Safety Gear

An approved motorcycle helmet is the most important part of your safety gear. An approved motorcycle helmet can help prevent a serious head injury. Choose a helmet that fits snugly. Motorcycle dealers can help in selecting a good quality helmet which fits properly.

You should wear eye protection when you ride. If a rock or a branch hits your eyes, the eye protection would protect you from injury. Remember to wear goggles or a face shield.

Wear proper clothing when you ride. The proper clothes can protect you from injury. Wear a good pair of gloves, strong boots that are over the ankle, and a long sleeve shirt

WARNING!

1. Checking maintenance items when the engine is running could be hazardous.

You could be severely injured if your hands or clothing get caught in moving ATV parts. Shut the engine off when performing maintenance checks, except checking the engine stop switch and throttle.

2. Operating this ATV without wearing an approved motorcycle helmet, eye protection, and protective clothing could be hazardous. Operating without an approved motorcycle helmet or eye protection would increase your chances of a severe head injury or death in an accident. Operating without protective clothing also increases your chances of severe injury in an accident. Always wear an approved motorcycle helmet which fits properly. Always wear eye protection (goggles or face shield). You should also wear gloves, boots, long sleeve shirt or jacket.

Break-In Period

The first month is the most important in the life of your riding. Proper operation during this Break-In period will be helpful for assuring maximum life and performance of your new vehicle. The following guidelines explain proper Break-In procedures.

Maximum Throttle Percentage Recommendation:

During the first 10 hours of operation, you should always use less than 1/2 throttle percentage.

Change the Engine Rotating Speed:

Change the engine rotating speed during the Break-In period, which make parts 'run', then 'unload' (permit parts to be cooling). Although it is just during the procedure of adding some pressure into engine parts Break-In period, please be careful that it would not be loaded too much to damage the engine.

Avoid Constant Low Rotating Speed:

Operating the engine at constant low rotating speed (light load) can cause parts to glaze and not seal properly. It's better to allow the engine to accelerate freely without exceeding the maximum throttle limit.

Allow the Engine Oil to Circulate Before Riding

Allow enough idling time after warm or cold engine starting, which can let the lubricating oil to reach all critical engine components.

Observe Your Initial Maintenance Time and the Most Critical Service

The initial service (break-in maintenance) is the most important service that your vehicle will receive. Operating a proper break-in will help engine components seal properly. Maintenance includes proper adjustments, tightening all bolts & nuts, and replacing dirty oil. Serving this in time will help your engine get the best service life and performance.

Brake System

To stop the ATV during riding, firstly release the throttle lever, then brake it slowly, that is to hold the front brake and kick the rear brake at the same time.

CAUTION!

1. Braking while turning the ATV could be hazardous. Use of the brake when turning could cause the ATV to slide or roll over. Use the brake to slow down before you begin to turn.
2. Braking hard on slippery road could be hazardous. The ATV could skid and go out of control if you brake too hard. Apply the brakes lightly and carefully on slippery road.
3. Operating the parking brake when the ATV is moving could be hazardous.

The front wheels could lock, and it will cause a skid and an accident.

Use the parking brake only after you stop the ATV.

Steering System

Turning the ATV improperly could be hazardous. If you turn the ATV improperly, it may cause a collision or overturn. Always follow proper procedures for turning as described in this section. Practice turning at low speeds before attempting to turn at higher speeds. Never turn at excessive speeds.

To turn the ATV, the rider must use the proper technique. Because this vehicle has a solid rear axle, both rear wheels always turn at the same speed. This means that if the rear wheels are getting equal traction, the vehicle will tend to move straight ahead. This is because the rear wheels will travel the same distance. For the vehicle to turn, the outside rear wheel must travel a longer distance than the inside rear wheel. To make this happen, the rider must create less traction for the inside wheel, allowing it to skid. This allows it to travel a shorter distance than the outside wheel. This happens even though both wheels are still turning at the same speed.

To turn ATV use the following technique:

- Move your body forward and to the inside of the turn.

- Turn the handlebar to the direction of the turn.

Use the same technique that you use when you move your body farther toward the inside of the turn to maintain your balance. Natural turning forces (which can push the vehicle to the outside of the turn) increase as the speed or the turn sharpness increases. This means you must lean your body farther into the turn as you go faster or turn more sharply. This prevents the Vehicle from tipping over to the outside of the turn. If your ATV starts to tip while turning, lean your body farther into the turn while gradually reducing the throttle and making the turn wider, if possible.

Skidding or Sliding

CAUTION: Skidding or sliding improperly could be hazardous. You may lose control of your ATV when you regain traction unexpectedly. This may cause the ATV to overturn. Learn to safely control skidding or sliding by practicing at low speeds and on level, smooth terrain. On extremely slippery surfaces, such as ice, go slow and be very cautious, in order to reduce the chance of skidding or sliding.

You may experience skidding or sliding when you are not braking. You may be able to overcome it by using the techniques listed below.

If your front wheel skids:

Gain front wheel traction by reducing the throttle opening and leaning your body slightly forward.

If your rear wheel skids:

If space permits, steer in the direction of the skid. Shift your body away from the skid slightly. Avoid using the throttle or brakes until you regain directional control of the vehicle.

Operation On Hills

To climb a hill with the ATV, follow the directions below.

1. Speed up and maintain a steady speed before reaching the top of the hill. Remember that you must ride at a steady speed all the way to the top of the hill.
2. Lean your body forward by sliding forward on the seat. Lean slightly forward. For steep hills, stand on the footrests and lean forward.
3. Maintain a steady speed while climbing the hill.
4. Slow down gradually when you reach the top of the hill.

If you climb a hill and are unable to make it to the top, use one of the correct procedures described below to get back down the hill. Never attempt to turn an ATV around on a steep hill, doing so could cause the ATV to overturn.

If your ATV loses power, pull back it following these instructions.

1. Lean uphill.

2. Never apply rear brake but use front brake.
3. Gradually back down the hill with body weight leaning forward while applying front brake. Use extreme caution when backing down a hill. If you still have forward movement and the hill is not steep and there is enough space to turn around safely, follow these instructions:
 1. Turn around on hill before you lose forward momentum. As you turn on side of hill, lean your body weight uphill.
 2. Once you have turned around, ride down hill as described in the DESCENDING A HILL section.

CAUTION:

1. Going down a hill improperly could be hazardous.
2. Going down a hill improperly could cause loss of control or cause the ATV to overturn.
3. Check the terrain carefully for any obstacles before you go down the hill, transfer body to the rear by sliding back on the seat.
4. Ride down the hill slowly with the throttle released, and apply the rear brake to control the speed.

Inspection and Maintenance

Maintenance Plan

It is very important to inspect and maintain your ATV regularly. Follow the guidelines in the chart. The intervals between periodic services in months are shown. At the end of each interval be sure to perform the maintenance listed.

Item	Interval	Initial 1 month	Every 3 months	Every 6 months
Air Cleaner		—	C	—
^Exhaust pipe bolt and muffler bolt		T	T	T
*Cylinder head,cylinder and muffler		—	C	C
Spark plug		—	C	R
Idle Speed		I	I	I
Throttle cable		I	I	I
*Fuel line		I	I	I
^Brakes		I	I	I
Tires	Inspect every month			
Drive Chain	Clean, lubricate and inspect each time the ATV is ridden			
*Suspension		—	—	I
*Steering		I	I	I
^Chassis bolts and nuts		T	T	T
Flexible tube		I	I	I
Brake fluid	Replace every 2 years			

I=Inspect and clean, adjust, lubricate or replace, if necessary. C=Clean R=Replace T=Tighten L=Lubricate

^Replace every 2 years

*Replace every 4 years

If you ride your ATV usually, you need to have it serviced more frequently.

◆ Maintenance for hydraulic brake system:

- 1) Inspect the brake fluid regularly, if necessary, please replace the brake fluid that is specified.
- 2) Replace the brake fluid per two years.
- 3) Replace brake soft pipe per four years.

WARNING: Don't take any chances not to maintain those parts which must be replaced, otherwise, it may result in injury or death.

◆ Spark plug

Spark plug is the key electrical parts, and it's easy to inspect it.

The heat and debris can rust the spark plug slowly, not making it discharge normally and having strong enough spark, so that it can't ignite the gas mixture. In order to make the engine work normally, you must maintain it regularly and replace the spark plug if necessary.

● Removing spark plug

1. Pull up the wire connecting cap of the spark plug;
2. Use the special tool for spark plug in the tool bag, screwing out the spark plug anticlockwise.

● Inspecting spark plug:

1. Inspecting whether the spark plug terminal which is wrapped with pottery (connecting with the wire cap) is oxidated or not.

CAUTION: It would affect conductivity if the terminal is oxidated or rusted, what's worse, it would make the engine power lower, fuel consumption rise up, leading to misfiring and cutout, this will result in the engine operation not stable, affect the normal work seriously. If you're not able to judge whether the terminal meets the requirement, please contact Kayo after-service agent for help.

2. Inspect whether the electrode of the spark plug has rust, carbon deposit or other sediment, if necessary, you must replace it.

Spark plug model:

A7RTC

3. Measure the clearance of the spark plug electrode, if necessary, adjust the clearance.

Spark plug electrode clearance: 0.6-0.7mm (0.024-0.028in)
--

● **Assembling the spark plug:**

1. Wash the spark plug gasket and its matching surface, and wipe up the dirt in the thread of the spark plug.
2. Screw the spark plug in the mounting hole with the special tool, tightening it according to the specified torque.

Spark plug tightening torque: 18Nm (1.8m*kgf, 13ft*lbf)
--

CAUTION: When assembling the spark plug, if there's no appropriate wrench, you can estimate whether it is tightened, after tightening spark plug, using spark plug wrench screw 1/4-1/2 will be fine. Of course, in this way, someone may not meet the requirement when assembling, you should check it with torque wrench.

3. Tighten wire cap on the terminal spark plug.

◆ **Engine Oil**

Running the engine without an adequate amount of engine oil could cause severe engine damage. Running the engine without any engine oil could cause engine overheating. Always check the amount of engine oil before starting the engine.

Changing engine oil

The engine oil should be changed every 20 to 40 hours of operation. It should be changed more often in dirty and dusty areas.

Procedures for changing engine oil:

1. Park the vehicle on level ground.
2. Remove the oil cap.
3. Remove the drain bolt and drain oil into proper container.
4. Reinstall the drain bolt
5. Pour fresh oil of the specified type through the oil fill hole.

NOTE: Approximately 1000ml of oil is required.

6. Tighten the oil cap, and check oil level.
7. Dispose of used oil as per governmental regulations.

◆Drive Chain/Engine Sprocket

Please check and adjust the drive chain before riding. Please follow the specific maintenance steps as bellow:

Checking the drive chain

When you check the chain, please check:

- if the pin is slack;
- if the sprocket is broken;
- if the chain is lack of lubrication or gets rusty;
- if the chain is bent or binding together;
- if the chain excessive wears.

If you found the chain has any problem, please maintain or directly change as new one. If necessary, please contact the local dealer. And please check if the sprocket is broken. Broken chain also damages the front and rear sprockets.

Drive chain cleaning, lubrication and adjustment

Cleaning and lubricating as following steps:

- 1.Clean the chain by water;
- 2.Dry the chain, and lubricate it by chain lubricant or other lubricant with same function.

No checking the drive chain before riding may cause serious result!

Serious slack may force chain out of sprocket, which may cause accident or seriously damage AT. Must check if chain slack before riding and make sure the chain can play for 20-30MM.

◆ Checking the Wheel Hub Bearing

The front and rear hub bearings must be checked at the intervals specified in the periodic maintenance and lubrication chart. Check if it's loose, moves axially or needs lubrication. If in riding, the bearing or the wheel does not turn smoothly, please contact the local dealer to repair.

Recommended lubricant:

Lithium lubricant grease

◆ **Checking swing arm bearing**

The swing arm bearing must be checked at the intervals specified in the periodic maintenance and lubrication chart. Check if it's loose, moves axially or needs lubrication. If in riding, the bearing or the wheel does not turn smoothly, please contact the local dealer to repair.

Recommended lubricant:
Lithium lubricant grease

◆ **Checking the upper and lower arm pivots**

The upper and lower arm pivots must be checked at the intervals specified in the periodic maintenance and lubrication chart. Check if the clearance is within specification, and if there is play in arm pivots. It is very important to lubricate the arm grease nipple with special lubricant tools.

Recommended lubricant:
Lithium lubricant grease

◆ **Checking and lubricating the steering**

The steering must be checked at the intervals specified in the periodic maintenance and lubrication chart. If there is any abnormal, please contact the local dealer.

Recommended lubricant:
Lithium lubricant grease

◆ **Battery**

When engine stop working, please do not keep headlight open for 3 minutes or more longer, which will make batter discharge and cause difficult start. If this happened, please recharge batter or change as new battery. At least place one hour after first liquid or charging.



WARNING!

Battery electrolyte is poisonous and dangerous, as it contains sulfuric acid, which can cause severe burns. Avoid contacting skin, eyes or clothing.

If happened, you must do as following:

- 1.External: flush with water.
- 2.Internal:drink large quantity of water or milk of magnesia, beaten egg or vegetable oil. Call a Prussian intermediately.
- 3.Eye:flush with water for 15 minutes and get prompt medical attention.

Battery produce explosive gas.Keep sparks, flame, cigarettes or other sources if ignition away, ventilate when charging or using in an enclosed space.

Keep away from children.

Troubleshooting

Although KAYO ATV receive a thorough inspection before shipment from factory, trouble may occur during operation. Any problem in fuel, compression or ignition systems can cause poor start and lose of power.

The following troubleshooting chart represents a quick and easy procedure for checking these vital systems by yourself. However, You should contact with local dealer for some of problems,because they have more professional skills and tools, and they know how to service your ATV properly.

Use only genuine KAYO replacement parts. Imitation parts cannot make sure your salty.

WARNING: Do not smoke when checking the fuel systems.

1.Fuel

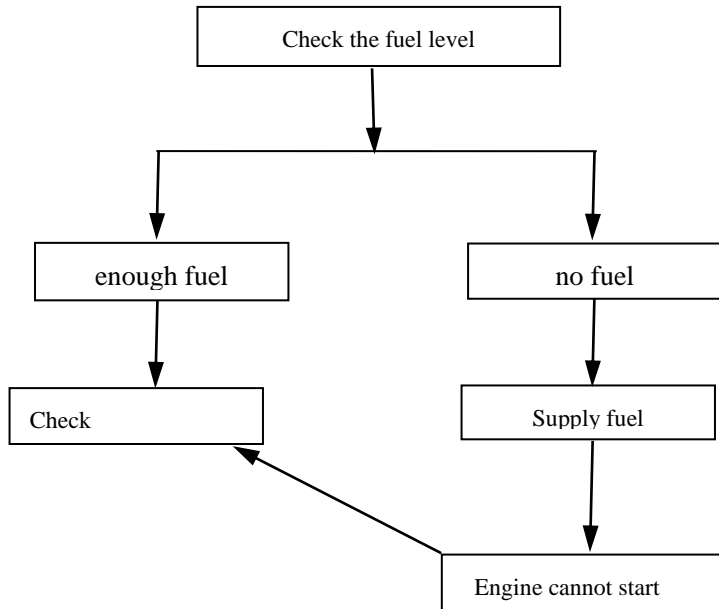

2.Compression

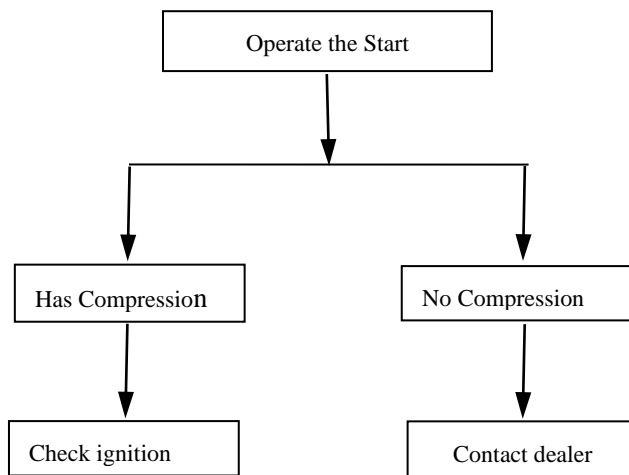

3. Ignition

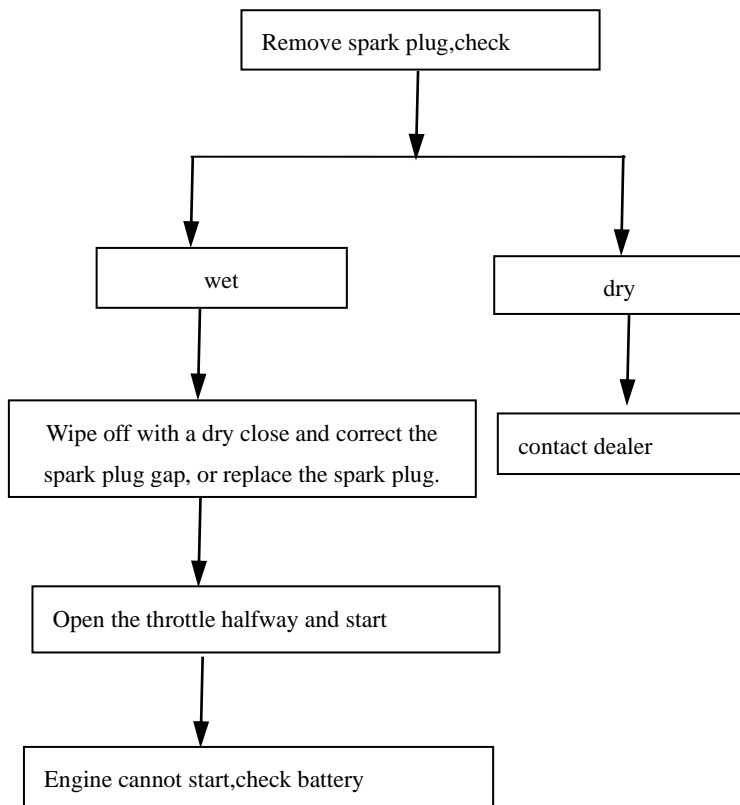

4. Battery

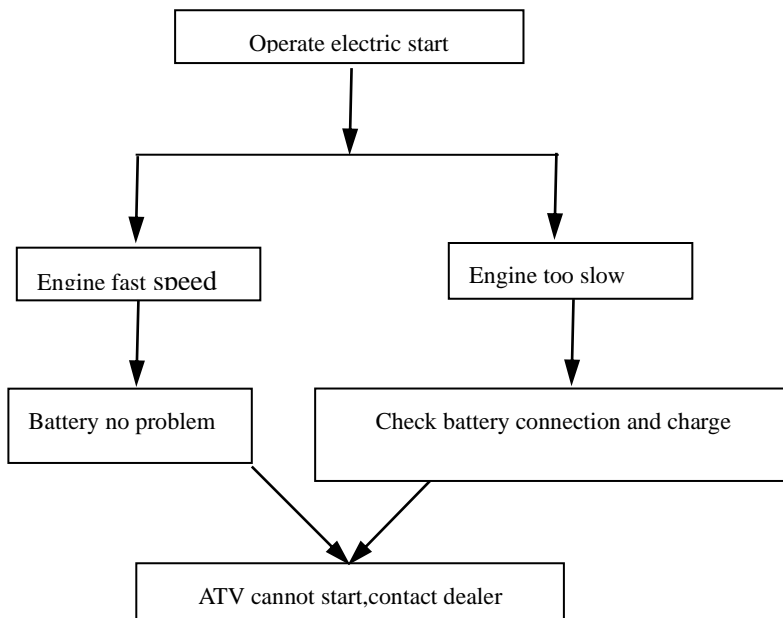

Unpacking and Assembly

1. Place the carton in a level surface or working table;
2. Cut the packing belt with scissors, lift up from the bottom of carton and remove the outside carton and steel frame;
3. Loosen and take off all bolts and nuts from frame. Attention: do not harm others. Remove the fixing bolt of front frame and the bracket then let the steel frame completely separate with the carton;
4. Assembly the front turning rod, nut and pin;
5. Assembly front wheel with 8pcs M10 nut and assembly rubber plug.



6. Assembling rear wheel: firstly you should inflate the rear tire, then assemble it. You need gasket, slotted nut, and cotter pin one piece for each, finally assemble the rubber plug.
7. Fixing the vehicle in the proper place, making sure that the hydraulic disc brake pump is horizontal, fastening the raisers bolts.



8. Putting the battery into the box after filling liquid, then assembling the upper fixing board, connecting with cables.
9. Assembling the bumper

After assembling and checking carefully the full bike, you can ride it.

AU180 Electrical Circuit Diagram

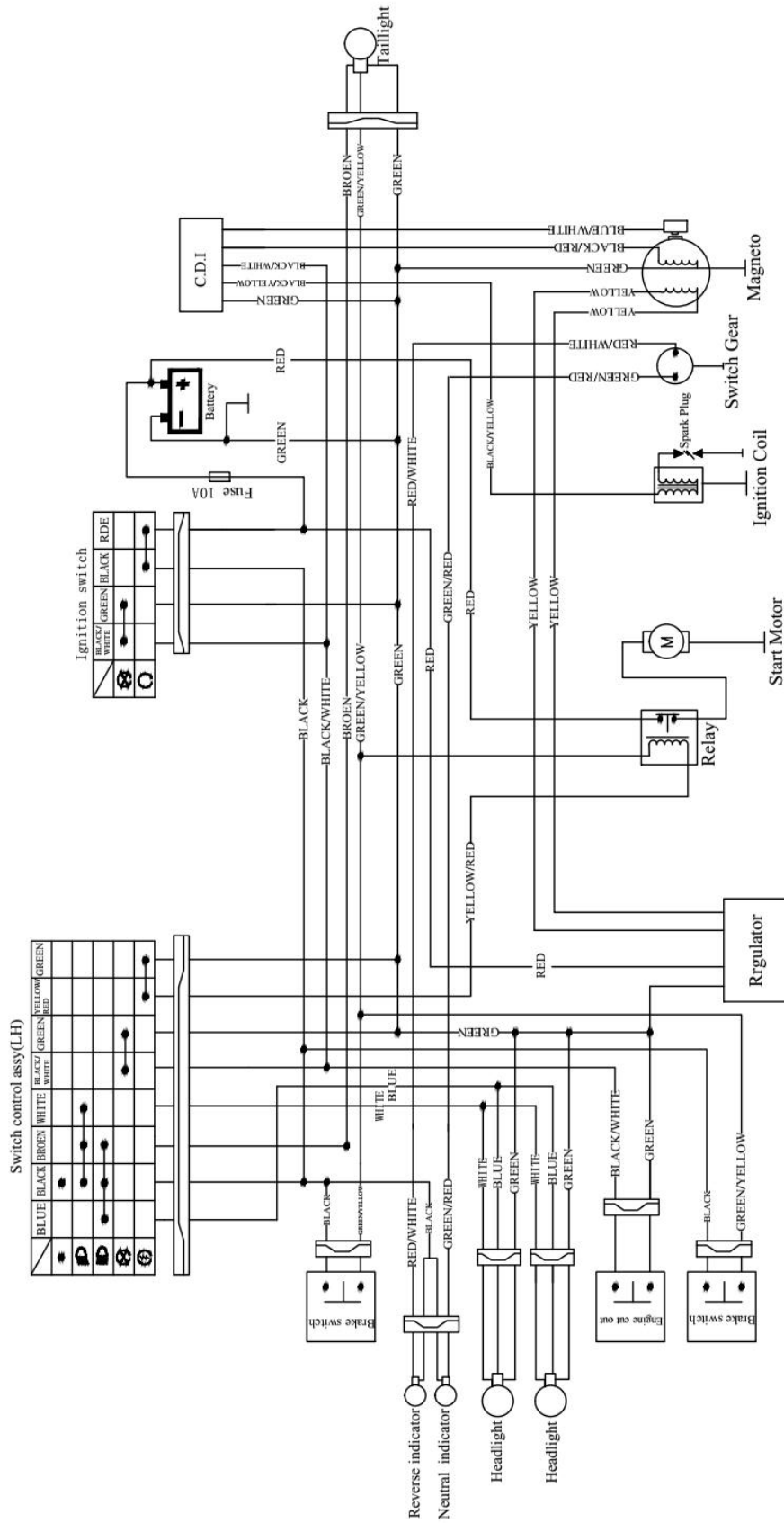

AU200-2 electrical circuit