

ZFORCE 950 Sport

ZFORCE 950 Sport-4

Owner's Manual

**READ THIS
MANUAL
CAREFULLY**

It contains important
safety information

Make sure operator holds a valid driver license.
Passengers under 12 years of age are prohibited.

TABLE OF CONTENTS

Foreword	7
Welcome	7
Signal Words	8
Introduction	11
Vehicle Identification Numbers and Key Information.....	12
ZFORCE 950 Sport ZFORCE 950 Sport - 4 Specifications	13
Operator Safety	20
General Safety Precautions	20
Owner Responsibilities.....	24
Safe Riding Gear.....	28
Safety Labels, Locations and Warnings	29
Occupants Protector	57
Hitch and Winch	60
Primary Controls	67
Secondary Controls.....	73
Secondary Controls.....	75
Other Functions.....	80
CVT System	81
Dashboard Indicators and Warnings.....	85

Indicators and Warnings.....	86
Operating Your Vehicle	93
Break-In Period	93
Recommended Engine Oil Viscosity	94
Pre-Ride Inspection.....	95
Throttle	95
Foot Brake.....	96
Starting the Engine.....	96
Shifting the Transmission	97
Responsibilities of the Operator	101
Practice Exercises.....	104
Operating Your Vehicle.....	107
Hauling and Towing Loads	112
Place a support under vehicle.....	120
Place a support under vehicle.....	121
Intended Use.....	122
Winch Operation	123
Maintenance.....	134
Severe Use Definition	134
Pre-Ride Maintenance Checklist.....	136
Break-In Maintenance Checklist	138

Periodic Maintenance Schedule.....	140
Inspection and Service Record	147
Maintenance Procedures	149
Air Filter	149
Inspect The Engine Oil Levels.....	152
Engine Valve Clearance Adjustment	157
Engine Idle Speed	157
Front and Rear Gear Case.....	158
Front and Rear Axle Boots	160
Cooling System	162
Spark Plug(s)	166
Battery.....	170
Brakes	174
Suspension Lubricating and Adjustment.....	177
Spring Preload Adjustment - ZFORCE 950 Sport / 950 Sport-4	178
Wheels	181
Electrical	183
Cleaning and Storage	187
Washing the Vehicle	187
Waxing the Vehicle	187
Perform Repairs	188

Check the Tires	188
Oil and Filter	188
Air Filter/ Air Box	188
Check Fluid Levels	189
Stabilize the Fuel.....	189
Battery Storage	189
Lubricate	189
'Fog' the Engine	189
Transporting the Vehicle	191
Vehicle Issue Diagnosis	192
Engine Doesn't Turn Over	192
Engine Pings or Knocks	192
Engine Stops or Loses Power	193
Engine Turns Over, Fails to Start	194
Engine Backfires	195
EFI Malfunction Indicator Light	196
EPS Malfunction Indicator Light	197
Electronic Power Steering (EPS) Fault Diagnosis and Solution	198
Declaration	199
Declaration of Drivers exposure to noise level.....	199

Declaration of Vibration declaration 200

CFMOTO LIMITED WARRANTY 201

Change of Ownership 206

Foreword

Welcome

Thank you for purchasing a CFMOTO vehicle, and welcome to our world-wide family of CFMOTO enthusiasts. Be sure to visit us at www.cfmoto.com for the latest news, new product introductions, upcoming events, and more.

CFMOTO, an international company that specializes in the development, manufacture and marketing of large displacement motorcycles, all terrain vehicles, utility vehicles, and core components (power sports liquid cooling engines, frames, etc). Founded in 1989, CFMOTO is always devoted to the developing routine of independent brand cultivation and independent R&D innovation. Now, CFMOTO products are distributed through more than 2000 companions worldwide for more than 100 countries and areas. CFMOTO is edging into the advanced ranks in the world in the power sports industry, and aims to supply superior products to dealers and fans globally.

For safe and enjoyable operation of your vehicle, be sure to follow the instructions and recommendations in this owner's manual. Your manual contains instructions for minor maintenance. Information about major repairs is outlined in the CFMOTO Service Manual.

Your CFMOTO dealer knows your vehicle best and is interested in your total satisfaction. Be sure to return to your dealership for all of your service needs during, and after, the warranty period.

Due to constant improvements in the design and quality of production components, some minor discrepancies may result between the actual vehicle and the information presented in this publication. Depictions and/or procedures in this publication are intended for reference use only.

This manual applies to the following models: CF1000UTR-6 CF1000STR-3L

Foreword

Signal Words

A signal word calls attention to a safety message or messages, a property damage message or messages, and designates a degree or level of hazard seriousness. The standard signal words in this manual are WARNING, CAUTION and NOTE or NOTICE.

The following signal words and symbols appear throughout this manual and on your vehicle. Your safety is involved when these words and symbols are used. Become familiar with their meanings before reading the manual:

WARNING

This safety alert and icon indicates a potential hazard that may result in serious injury or death.

CAUTION

This safety alert and icon indicates a potential hazard that may result in minor or moderate personal injury and/or damage to the vehicle.

CAUTION

This safety alert without an icon indicates a situation that may result in damage to the vehicle.

NOTE or NOTICE

A note or notice will alert you to important information or instructions.

Foreword



NEVER:

- Operate without proper training or instruction.
- Operate at speeds too fast for your skill, conditions, or the terrain.
- Carry multiple passengers, these vehicles are designed for two passengers only.
- Use ALCOHOL or DRUGS before or while driving this vehicle.
- Overload the vehicle when driving.

ALWAYS:

- Use proper driving techniques to avoid vehicle overturn on hills, rough terrain, and when turning.
- Wear approved, suitable helmet, eyes protection and protective gear for operator and passenger.
- Use safety belt during operation.

Foreword
READ THE OWNER'S MANUAL
FOLLOW ALL INSTRUCTIONS AND WARNINGS

 WARNING

Read, understand, and follow all of the instructions and safety precautions in this manual and on all product labels. Failure to follow the safety precautions could result in serious injury or death.

 WARNING

The engine exhaust gas from this product contains CO, which is deadly gas and could cause headaches, giddy, or lose consciousness, even death.

 WARNING

Engine box cover, brake disc and muffler exhaust pipe will be hot easily after long period usage. Avoid being burned by those parts.

Introduction

Thank you for purchasing a CFMOTO vehicle.

This Owner's Manual is intended to acquaint the owner/operator with the various vehicle controls and safe operating instructions. It contains important safety information, driving skills, along with basic maintenance and inspection procedures. If you have any questions regarding the operation or maintenance of your vehicle, please consult a CFMOTO dealer.

CAUTION:

Please respect the following instructions to protect your catalytic converter.

- Use only unleaded gasoline, even if the gasoline contains a little lead. Lead could damage the noble metal contained in catalytic converter and disable it.
- Never add the rust preventive oil and engine oil into muffler, otherwise it could disable the catalytic converter.

Introduction

Vehicle Identification Numbers and Key Information

Record your vehicle's identification numbers in the spaces provided. Remove the spare key and store in a safe place. Your key can be duplicated only by mating a key blank with one of your existing keys. If both keys are lost, the complete lock assembly must be replaced.

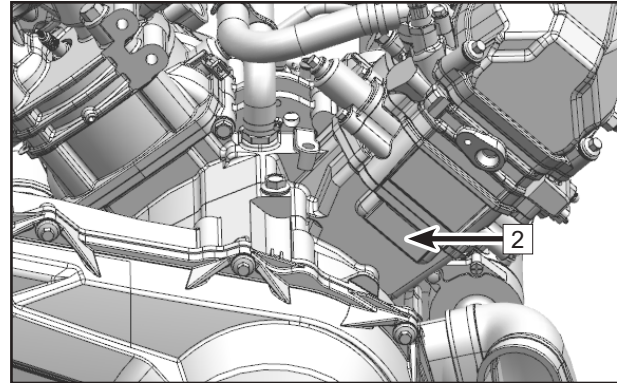
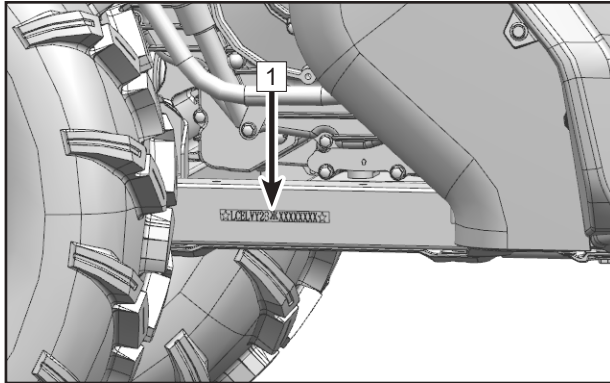

1. Vehicle Identification Number: _____

2. Engine Serial Number: _____

Specifications

ZFORCE 950 Sport ZFORCE 950 Sport - 4 Specifications

Item	ZFORCE 950 Sport	ZFORCE 950 Sport-4
	CF1000UTR-6	CF1000STR-3L
Overall Length	120.6 in. (3065 mm)	150.7 in. (3827mm)
Overall Width	60 in. (1524 mm)	
Overall Height	73.6 in. (1870 mm)	74 in. (1880 mm)
Wheel Base	90 in. (2286 mm)	120 in. (3048mm)
Ground Clearance	12 in. (305 mm)	
Minimum Turning Radius	207 in.(5250mm)	236 in. (6000 mm) with differential rear gearcase 246 in. (6250 mm) with non-differential rear gearcase
Basic Weight	1488 lb. (675 kg)	1752 lb. (795 kg)
Rear Cargo Box Weight Capacity	330.6 lb. (150 kg)	330.6 lb. (150 kg)
Maximum Vehicle Load Allowed	661.4 lb. (300 kg)	1047.2 lb. (475 kg)
Recommended Towing Capacities:		
Towing Hitch Weight (Non-bracket)	119 lb. (54 kg)	119 lb. (54 kg)
Trailer and Cargo Weight	1190 lb. (540 kg)	1190 lb. (540 kg)
Engine Model And Type	2V91Y-H	
Type	V-twin, 4-stroke, liquid-cooled, 8 valves, SOHC	

Specifications

Item	ZFORCE 950 Sport	ZFORCE 950 Sport-4
	CF1000UTR-6	CF1000STR-3L
Bore × Stroke	3.5 in. × 2.9 in. (91 mm × 74 mm)	
Displacement	963 mL	
Compression Ratio	10.8 : 1	
Starting Type	Electric start	
Lubrication Type	Pressure / Splash lubrication	
Engine Coolant:		
Type	Commercially available – Safe for aluminum engines	Commercially available – Safe for aluminum engines
Capacity	4.33 qt. (4.1 L)	5.1 qt. (4.8 L)
Mix Ratio	50% coolant / 50% distilled water	50% coolant / 50% distilled water
Engine Oil:		
Type	SAE 10W-40 / SAE 5W-40 / SAE 15W-40 SJ or higher (See page 94 for oil viscosity chart)	
Engine Oil Volume:	2.75 qt. (2.6 L)	
Capacity Change / Oil Filter	2.64 qt. (2.5 L)	
Transmission		
Type	SAE 75W-90 GL-5	
Engine oil volume	0.63 qt. (0.6 L)	

Specifications

Item	ZFORCE 950 Sport	ZFORCE 950 Sport-4
	CF1000UTR-6	CF1000STR-3L
Front gear case Oil:		
Type	SAE 80W-90 GL-5	
Volume:		
Periodic Oil Change	8.5 oz. (250 mL)	
Rear gear case Oil:		
Type	SAE 80W-90 GL-5	
Volume		
Periodic Oil Change	13.5 oz. (400 mL)	
Air Filter	Paper type	
Fuel Type	95(ROn) or E10	
Fuel Tank Capacity	9.77 gal. (37 L)	
Fuel Reserve Amount At Fuel Gauge 'Flash' (Approximate)	1.6 gal. (6.2 L)	

Specifications

Item		ZFORCE 950 Sport	ZFORCE 950 Sport-4	
		CF1000UTR-6	CF1000STR-3L	
Spark Plug Type		CR8EK (NGK)		
Spark Plug Gap		0.026 in. ~ 0.030 in. (0.65 mm ~ 0.75 mm)		
Transmission	Transmission	CVT + Gearbox		
	Gear Shift/Order	Manual / P-R-N-H-L		
	CVT Ratio	0.70 ~ 2.88		
	Gear Ratio	Low Gear	6.585	
		High Gear	2.975	
Reverse		5.807		
Chassis Frame	Steel tube			
Tires:		Tubeless		
Type		27 × 9.00 - 14 8PR (60L) / 27 × 9.00R14 8PR (60L)		
Front		27 × 11.00 - 14 8PR (67L) / 27 × 11.00R14 8PR (66L)		
Rear		4x110 mm		
Wheel Bolt Pattern		4x110 mm		

Specifications

Item	ZFORCE 950 Sport CF1000UTR-6
Tire Pressure: Front	Recommended tire pressure: 80 kPa Full-load tire pressure: 100 kPa
Rear	Recommended tire pressure: 100 kPa Full-load tire pressure: 120 kPa
Brake System:	Front axles: Double-disc / Rear axles: Double-disc
Foot Brake Type / Operation	Foot operated Four wheel disc
Parking Brake Type / Operation	Operated by hand Rear wheel mechanical disc brake only
Brake Fluid Type	DOT 4
Suspension: Front Suspension	Double A-arm independent
Rear Suspension	Double A link rod suspension

Specifications

Item	ZFORCE 950 Sport-4 CF1000STR-3L
Tire Pressure: Front	Recommended tire pressure (2 person): 120 kPa When fully loaded, front pressure(4 person): 150 kPa
Rear	Recommended tire pressure (2 person): 120 kPa When fully loaded, front pressure(4 person): 150 kPa
Brake System:	Front axles: Double-disc / Rear axles: Double-disc
Foot Brake Type / Operation	Foot operated Four wheel disc
Parking Brake Type / Operation	Operated by hand Rear wheel mechanical disc brake only
Brake Fluid Type	DOT 4
Suspension:	
Front Suspension	Double A-arm independent
Rear Suspension	Double A link rod suspension

Specifications

Item	ZFORCE 950 Sport	ZFORCE 950 Sport-4
	CF1000UTR-6	CF1000STR-3L
Shock Absorber:		
Front Shock Absorber	Airbag	
Rear Shock Absorber	Airbag	
Wheel Travel:		
Front Wheel Travel	12.1 in. (307 mm)	
Rear Wheel Travel	13.1 in. (334 mm)	
Electrical System:		
Ignition	Electronic	
Charging	Rectified A/C 600 Watt @ 5000 rpm	
Battery	12 Vdc / 30 Amp Hr	

Operator Safety

General Safety Precautions

WARNING

Failure to heed the warnings contained in this manual can result in serious injury or death. This vehicle is not a toy and can be hazardous to operate. This vehicle handles differently from other vehicles, such as cars. A collision or rollover can occur quickly, even during routine maneuvers like turning or driving over obstacles, if you fail to take proper precautions.

Read this owner's manual. Understand all safety warnings, precautions and operating procedures before operating this vehicle.

Age Restrictions

This vehicle is an **ADULT VEHICLE ONLY**. Driver must be at least 16 years old with a valid driver's license to operate. No passengers under age 12 are allowed on CFMOTO vehicles designed to carry passengers.

Know Your Vehicle

As the operator of the vehicle, you are responsible for your personal safety, the safety of others, and the protection of the environment. Read and understand your owner's manual, which includes valuable information about all aspects of your vehicle, including safe operating procedures.

Operator Safety

Equipment Modifications

CFMOTO is concerned with the safety of our customers and for the general public. Therefore, we strongly recommend that consumers do not install on a vehicle, any equipment that may increase the speed or power of the vehicle, or make any other modifications to the vehicle for these purposes. Any modifications to the original equipment of the vehicle create a substantial safety hazard and increase the risk of body injury. The warranty on your vehicle is terminated if any unapproved accessory equipment has been added to the vehicle, or if any modifications have been made to the vehicle that increase its speed or power.

NOTE:

The addition of certain accessory equipment which may change the handling and performance characteristics of the vehicle include, but are not limited to; mowers, plow blades, oversize tires, sprayers, large racks, lift kits and trailers. Use only approved accessories, and familiarize yourself with their function and effect on the vehicle.

Avoid Carbon Monoxide Poisoning

All engine exhaust contains carbon monoxide, a deadly gas. Breathing carbon monoxide can cause headaches, dizziness, drowsiness, nausea, confusion and eventually death.

Carbon monoxide is a colorless, odorless, tasteless gas that may be present even if you do not see or smell any engine exhaust. Deadly levels of carbon monoxide can collect rapidly, and you can quickly be overcome and unable to save yourself. Also, deadly levels of carbon monoxide can linger for hours or days in enclosed or poorly ventilated areas.

To prevent serious injury or death from carbon monoxide:

- Never run the vehicle in poorly ventilated or partially enclosed areas.
- Never run the vehicle outdoor where engine exhaust can be drawn into a building through openings such as windows and doors.

Operator Safety

Avoid Gasoline Fires and Other Hazards

Gasoline is extremely flammable and highly explosive. Fuel vapors can spread and be ignited by a spark or flame many feet away from the engine. To reduce the risk of fire or explosion, follow these instructions:

- Use only an approved gasoline container to store fuel.
- Never fill the gasoline container in the vehicle cargo box or on the vehicle. An electrical static discharge may ignite the fuel.
- Strictly adhere to proper fueling procedures.
- Never start or operate the engine if the fuel cap is not properly installed. Gasoline is poisonous and can cause injury or death.
- Never siphon gasoline by mouth.
- If you swallow gasoline, get any in your eye (s), or inhale gasoline vapor, see a doctor immediately.
- If gasoline spills on you, wash with soap and water and change your clothes.

Fuel Minimum Octane Rating and Safety Warnings

The recommended fuel for your vehicle is E10 or 95(ROn). Non-oxygenated (ethanol-free) fuel is recommended for best performance in all conditions.

Operator Safety

WARNING

Gasoline is highly flammable and explosive under certain conditions.

Allow the engine and exhaust system to cool before filling the tank.

Always exercise extreme caution whenever handling gasoline.

Always refuel with the engine stopped, and outdoors or in a well ventilated area.

Never carry a plastic container with gasoline in the cargo area while riding. Static electricity between the cargo area and container could cause a spark.

Do not smoke or allow open flames or sparks in or near the area where refueling is performed, or where gasoline is stored.

Do not overfill the tank. Do not fill to the tank neck.

If gasoline spills on your skin or clothing, immediately wash it off with soap and water and change clothing.

Never start the engine or let it run in an enclosed area. Engine exhaust fumes are poisonous and can cause loss of consciousness or death in a short time.

The engine exhaust from this product contains chemicals known to cause cancer, birth defects or other reproductive harm. Operate this vehicle only outdoors or in well-ventilated areas.

Avoid Burns from Hot Parts

The exhaust system and engine become hot during operation. Avoid contact during and shortly after operation to avoid burns.

Operator Safety

Owner Responsibilities

Be Qualified and Responsible

Read this Owner's Manual and the warning decals on this vehicle carefully. Take a safety training course on open areas if available. Practice at low speeds. Higher speeds require greater experience, knowledge and suitable riding conditions. Become completely familiar with the operational controls and the general operation of the vehicle.

This vehicle is an ADULT VEHICLE ONLY. Operation is prohibited for anyone under 16 years of age. Operators must be tall enough to be properly seated back against the backrest with the seat belt fastened, to hold the steering wheel with both hands and still be able to reach the full stroke of brake and throttle pedals with the right foot, and able to firmly plant their left foot on the footrest.

The operator must acquire a driving license as required by local laws and regulations.

Carrying a Passenger

- Only carry one passenger (For ZFORCE 950 Sport-4, only 3 passengers are allowed), The passenger must be properly seated in the passenger seat.
- The passenger must be at least 12 years old and tall enough to always be properly seated against the backrest with the seat belt fastened, holding handhold, and feet firmly planted; right foot on the footrest and the left foot on the vehicle floor.
- Never carry a passenger who has used drugs or alcohol, or is tired or ill. These slow reaction time and impair judgment.
- Instruct the passenger to read the vehicle's safety labels.
- Never carry a passenger if you judge their ability or judgment is insufficient to concentrate on the terrain conditions and adapt accordingly. More specifically for side-by-side vehicles, the passenger

Operator Safety

must also pay constant attention to the terrain ahead and be able to brace for bumps.

Riding Carefully

- This vehicle is not a toy and can be hazardous to operate. This vehicle handles differently from other vehicles such as motorcycles or cars. A collision or rollover can occur quickly, during abrupt maneuvers such as sharp turns, acceleration or deceleration, and driving on hills or over obstacles if you fail to take proper precautions.
- Never operate at excessive speeds. Always operate at a speed that is proper for the terrain, visibility, and operating conditions, and your experience.
- Never attempt jumps, side slides, donuts, or any other stunts.
- Never attempt rapid acceleration or deceleration when performing a sharp turn. This may result in a rollover.
- Never attempt skidding or sliding. If vehicle starts to skid or slide, counter steer in the direction of skidding or sliding. On extremely slippery surfaces, such as ice, go slowly and be very cautious in order to reduce the chance of skidding out of control.
- Always be sure there are no obstacles or people behind the vehicle when reversing. Pay attention to blind spots. When it is safe to proceed in reverse, go slowly.
- Never exceed the stated load limits for this vehicle. Cargo must be properly secured. Reduce speed, allow for greater braking distance and follow other instructions in this manual.
- Ensure that cargo is well distributed in the cargo box. Otherwise, it could change the center of gravity and may result in rollover.

Operator Safety

Roll Over Protection System (ROPS)

- The ROPS on this vehicle meets the performance requirements of ISO 3471:2008. The ROPS can limit intrusions of outside objects and reduce your risk of injury in rollovers.
- Always follow all safe operating practices outlined in this manual to avoid vehicle rollover.
- Do not put your hands and/or feet outside of the vehicle when driving. The ROPS will not protect you from injury in all rollovers.
- Always have your authorized CFMOTO dealer thoroughly inspect the ROPS if it ever becomes damaged in any way.

Occupant Restraint System

- This vehicle is designed to carry one driver and one passengers (For ZFORCE 950 Sport-4, one driver and three passengers are allowed), both wearing proper protective gear.
- The driver and passenger must latch the side doors or side nets and wear the seat belts at all times when riding.

Terrain Conditions

- Avoid sharp turns, abrupt acceleration and sudden braking when passing public roads.
- Always go slowly and be extra careful when operating on unfamiliar terrain. Always be alert to changing terrain conditions when operating this vehicle. Take the time to learn how the vehicle performs in different environments.
- Never operate on excessively rough, slippery or loose terrain until you have learned and practiced the skills necessary to control this vehicle on such terrain. Always be especially cautious on these kinds of terrain.
- Never operate this vehicle on hills too steep for the vehicle or your abilities. Practice on small inclines.

Operator Safety

- Always follow proper procedures for climbing or going down hills. Never go over the top of any hill at high speed.
- Never attempt steep hills or side hilling when pulling a trailer.
- Always check for obstacles before operating in a new area. Always follow proper procedures when operating over obstacles or fallen trees.
- Never operate this vehicle in deep water or fast flowing water. Remember that wet brakes may have reduced stopping ability. Test your brakes after leaving water. If necessary, apply them several times while driving slowly to let friction dry out the brakes.
- Always ensure to properly park the vehicle on the flattest terrain section available. Put the shift lever in PARK, stop the engine, and remove the key before leaving the vehicle.
- Never assume that the vehicle will go everywhere safely. Sudden changes in terrain caused by holes, depressions, banks, softer or harder ground, or other irregularities may cause the vehicle to topple or become unstable. To avoid this, slow down and always observe the terrain ahead. If the vehicle begins to topple or rollover, please hold the steering wheel tightly with both hands and cling your back to the seat back.
- Never attempt to prevent a rollover with your arms or legs. Always keep limbs inside the ROPS cage.

Operator Safety

Safe Riding Gear

Always wear clothing suited to the type of riding. Operating this vehicle requires wearing special protective clothing for comfort and to reduce the chance of injury:

1. A helmet is the most important piece of protective gear for safe riding. An approved helmet can prevent a severe head injury.
2. Eye protection. A pair of goggles or a helmet face shield offers the best protection for your eyes. They should be kept clean and be a shatter-proof design. Do not depend on sunglasses for proper eye protection.
3. Off-road style gloves with knuckle pads are the best for comfort and protection.
4. The best footwear is a pair of strong over-the-calf boots with heels.
5. Always wear long pants and long sleeve shirts to protect arms and legs. Riding pants and a jersey that have kneepads and shoulder pads provide the best protection.

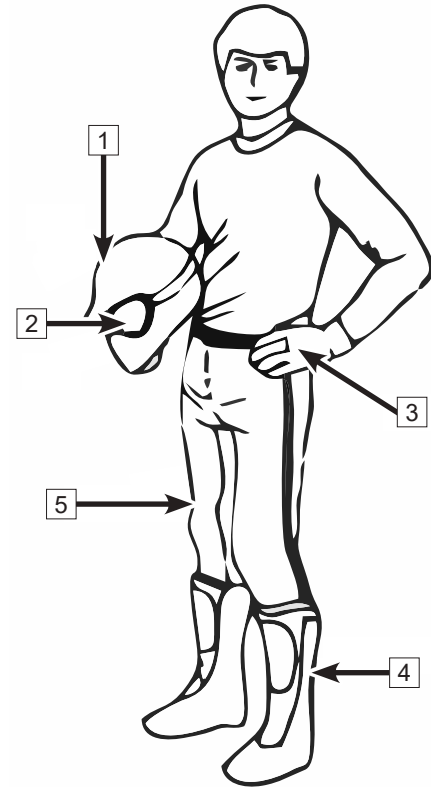

Operator Safety

Safety Labels, Locations and Warnings

Warning labels have been placed on the vehicle for your protection. Read and follow the instructions on each decal carefully. If a decal becomes illegible or comes off, contact your dealer to purchase a replacement. Read and follow the safety warnings in this manual.

ZFORCE 950 Sport

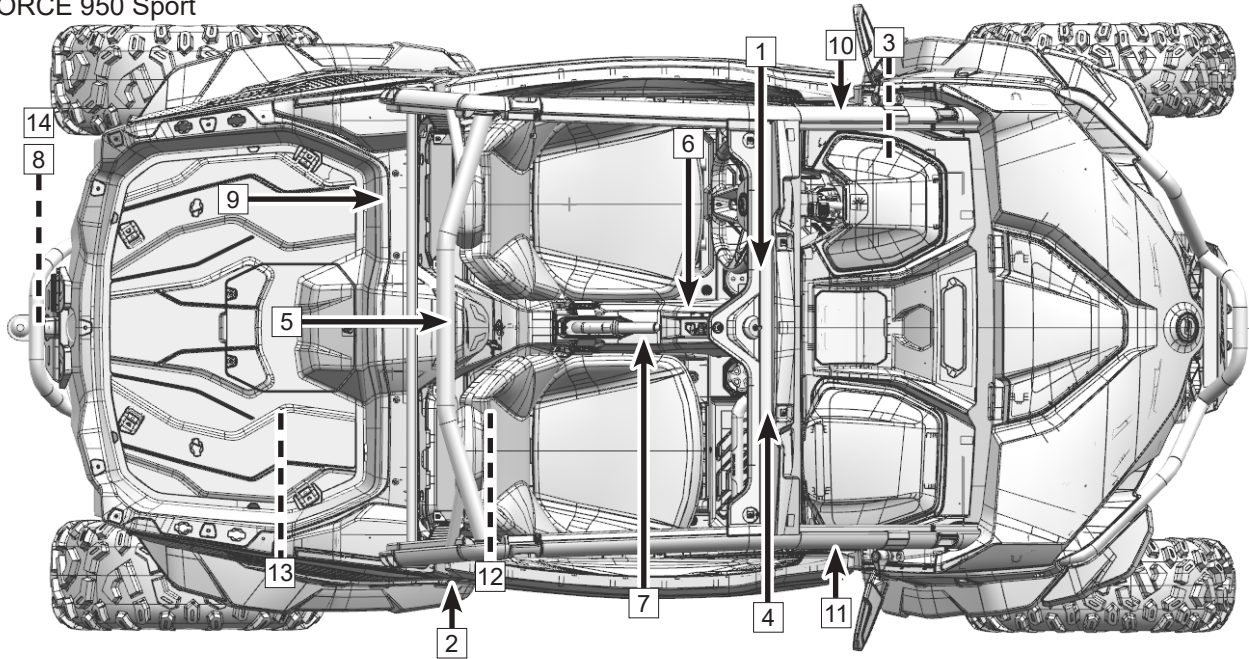

Operator Safety

ZFORCE 950 Sport-4

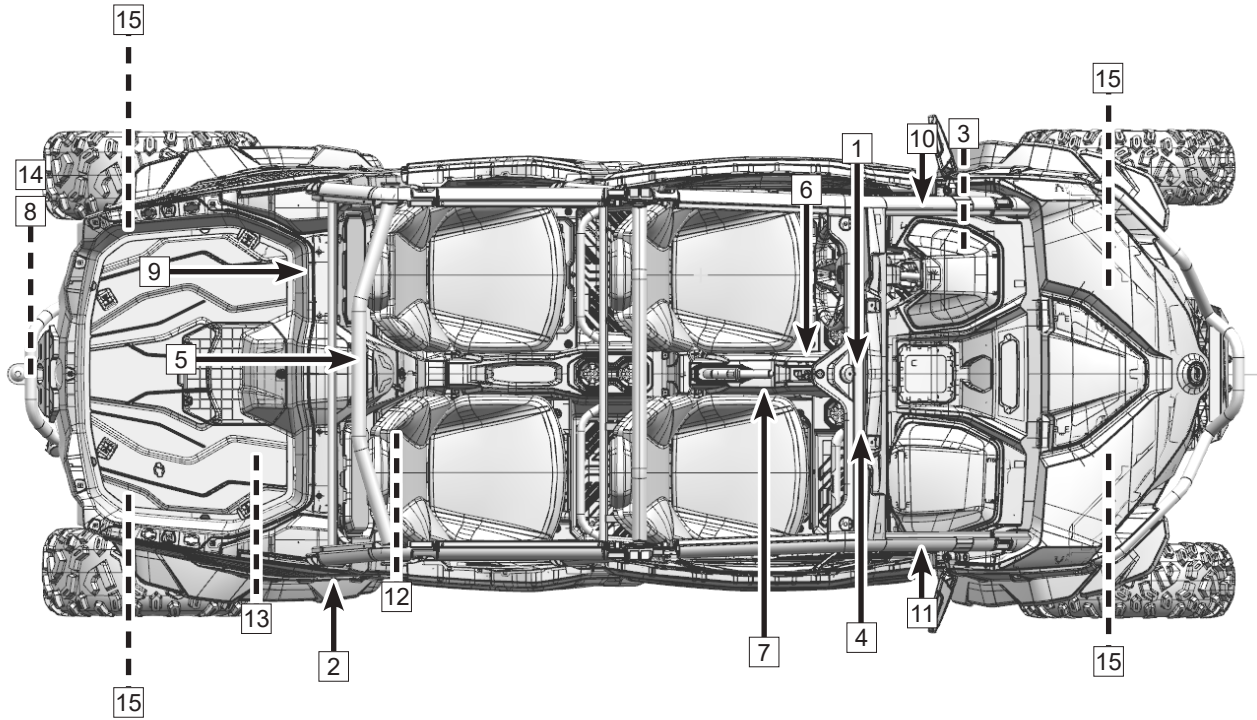

Operator Safety

Safety Labels - ZFORCE 950 Sport

1

⚠ WARNING

Improper use can result in severe INJURY or DEATH

Be Prepared

- Fasten seat belts and make sure nets or doors are securely latched in place.
- Wear an approved helmet and protective gear.
- Each rider must be able to sit with back against seat, foot flat on the floor or on footrest, and hands on steering wheel or handholds. Stay completely inside the vehicle.

Drive Responsibly

Avoid loss of control and rollovers:



- Avoid abrupt maneuvers, sideways sliding, skidding or fishtailing, and never do donuts.
- Avoid hard acceleration when turning, even from a stop.
- Slow down before entering a turn.
- Plan for hills, rough terrain, ruts, and other changes in traction and terrain.
- Avoid paved surfaces.
- Avoid side hilling (riding across slopes).

Rollovers have caused severe injuries and death, even on flat, open areas.

Be Sure Riders Pay Attention and Plan Ahead

If you think or feel the vehicle may tip or roll, reduce your risk of injury:

- Keep a firm grip on the steering wheel or handholds and brace yourself.
- Do not put any part of your body outside of the vehicle for any reason.
- NEVER attach to the cage to pull a load. This can cause the vehicle to tip over.

Read the Operator's Guide and Safety Labels and Watch the Safety Video. Follow All Instructions and Warnings.

5BYV-190001-9000 EU229

2

E5

E10



Bleifreies Benzin 

Unleaded fuel only

Carburant sans plomb

Gasolina sin plomo

Bezolovnatý benzin

Endast blyfri bensin

RON/ROZ min. 95

9GQA-190201-1 EU187

3

WINCH CONTROL HANDLE OUTLET

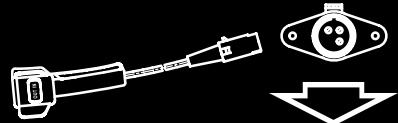

5HY0-190021 US182

Operator Safety

Safety Labels - ZFORCE 950 Sport

4

⚠ WARNING

Require Proper Use of Your Vehicle
Do your part to prevent injuries:

- Do not allow careless or reckless driving.
- Make sure operator holds a valid driver license.
- Do not let people drive or ride after using alcohol or drugs.
- Do not allow operatin on public roads-collisions with cars and trucks can occur.
- Do not exceed seating capacity:1 occupants.
- Never operate with a passenger under the age of 12.All riders must be able to sit with backs against the seat.

Both feet flat on the floor and both hands on the steering wheel (if driving) or on a passenger hand hold.

Read the Operator's Guide and Safety Labels and watch the Safety Video.Follow All Instruction and Warnings.



Improper tire pressure or overloading can cause loss of control.
Loss of control can result in severe injury or death.

- Cold tire pressure:
Front:11.6psi(80kPa)
Rear:14.5psi(100kPa)



Read the Operator's Guide and Safety Labels and Watch the Safety Video. Follow All Instructions and Warnings.

5BYV-190002-9000 EU229

5

5BY6-ROPS

CFMOTO

5BYV-190015-9000 EU228

Operator Safety

Safety Labels - ZFORCE 950 Sport

6

NOTICE

Check engine oil every 500 kilometers (310 miles)
Vérifier le niveau d'huile moteur tous les 500 kilomètres (310 miles)

905B-190413-US13C

8

WARNING

Improper loading of a trailer may cause loss of vehicle control, resulting in severe injury or death.

- Maximum unbraked towing mass **1190 lbs. (540 kg)**.
- Maximum unbraked tongue mass **119 lbs. (54 kg)**.

5BYV-190013-9000 EU22B

7

WARNING

 ● To avoid transmission damage, shift only when vehicle is stationary and at idle.

APPLY BRAKE TO START

- When this vehicle is not in operation or unattended, place shift in the park position.
- Stop the vehicle and apply the Brake before using the Shift Lever, the 2WD/4WD Switch and the Diff Lock Switch.

5BWV-190014-5000 US219

Operator Safety

Safety Labels - ZFORCE 950 Sport

9

⚠ WARNING

Severe **INJURY** or **DEATH** can result if you ignore the following:

- Maximum Load in Cargo Bed: **330lbs(150kg)**.
- Never carry passengers in cargo bed.
- Cargo can affect handing and stability. Read Owner's Manual before loading or towing.
- When loading with cargo or towing a trailer: Reduce speed and allow more room to stop. Avoid hills and rough terrain.
- Be sure cargo is secured a loose load could change handing unexpectedly.
- Keep weight in the cargo bed centered, and as low and far forward as possible. Top heavy loads increase the risk of overturn.



5BWV-190012-5000 US219

10

⚠ WARNING





Be prepared in case of rollover
If the vehicle rolls over, any part of your body (such as arms, legs, or head) outside of the cockpit can be crushed by the cage or other parts of the vehicle. Fasten seat belt and make sure net and/or door is securely latched in place to help you avoid sticking out arms or legs.

NEVER hold the cage while riding.
NEVER try to stop a rollover using your arm or leg.

5ASV-180021-6G00 US370

11

⚠ WARNING





Be prepared in case of rollover
If the vehicle rolls over, any part of your body (such as arms, legs, or head) outside of the cockpit can be crushed by the cage or other parts of the vehicle. Fasten seat belt and make sure net and/or door is securely latched in place to help you avoid sticking out arms or legs.

NEVER hold the cage while riding.
NEVER try to stop a rollover using your arm or leg.

5ASV-180022-6G00 US370

12

NOTICE

Transmission oil:
Type: 75W/90/GL-5
Oil volume: 0.6L
Capacity change: 0.6L

9AWA-190008 EU179

13

NOTICE

Engine oil:
Type: SAE10W-40 SG or higher
Engine oil volume: 2.6L
Capacity change / no oil filter: 2.4L
Capacity change / oil filter: 2.5 L

9AW#-190007-2410 EU201

14

E13

CFMOTO

S100

55R-014195

A50-X D5.12

9GQ0-190006 EU206

Operator Safety

Safety Labels - ZFORCE 950 Sport - 4

1

⚠ WARNING

Improper use can result in severe INJURY or DEATH

Be Prepared

- Fasten seat belts and make sure nets or doors are securely latched in place.
- Wear an approved helmet and protective gear.
- Each rider must be able to sit with back against seat, feet flat on floor or on foot rests, and hands on steering wheel or handholds. Stay completely inside the vehicle.

Drive Responsibly

Avoid loss of control and rollovers:

- Avoid abrupt maneuvers, sideways sliding, skidding, or fishtailing, and never do donuts.
- Slow down before entering a turn.
- Avoid hard acceleration when turning, even from a stop.
- Plan for hills, rough terrain, ruts, and other changes in traction and terrain. Avoid paved surfaces.
- Avoid side hilling (riding across slopes).

Be Sure Riders Pay Attention and Plan Ahead

If you think or feel the vehicle may tip or roll, reduce your risk to injury:

- Keep a firm grip on the steering wheel or handholds and brace yourself.
- Do not put any part of your body outside of the vehicle for any reason.



Rollovers have caused severe injuries and death, even on flat, open areas.

Read the Operator's Guide and Safety Labels and watch the Safety Video. Follow All Instruction and Warnings.

5BYV-190002-6300 EU234

2

E5



Bleifreies Benzin 

Unleaded fuel only

Carburant sans plomb

Gasolina sin plomo

Bezolovnatý benzin

Endast blyfri bensin

RON/ROZ min. 95

E10

9GQA-190201-1 EU187

3

WINCH CONTROL HANDLE OUTLET

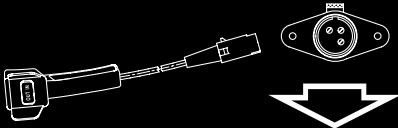

5HY0-190021 US182

Operator Safety

Safety Labels - ZFORCE 950 Sport - 4

4

⚠ WARNING

Require Proper Use of Your Vehicle

Do your part to prevent injuries:

- Do not allow careless or reckless driving.
- Make sure operator holds a valid driver license.
- Do not let people drive or ride after using alcohol or drugs.
- Do not allow operation on public roads (unless designated for off-highway vehicle access) - collisions with cars and trucks can occur.
- Do not exceed seating capacity: 3 passengers.
- All riders must be able to sit with backs against the seat.
Both feet flat on the floor and both hands on the steering wheel (if driving) or on a passenger hand hold.



Improper tire pressure or overloading can cause loss of control. Loss of control can result in severe injury or death.

- Cold tire pressure:

	2 OCCUPANTS	4 OCCUPANTS
Front	17 psi (120kPa)	22 psi (150kPa)
Rear	17 psi (120kPa)	22 psi (150kPa)

Read the Operator's Guide and Safety Labels and watch the Safety Video. Follow All Instruction and Warnings.

5BYV-190011-6300 EU234

5

5BY8-ROPS

CFMOTO

5BYV-190015-6300 EU232

6

NOTICE

Check engine oil every 500 kilometers (310 miles)
Vérifier le niveau d'huile moteur tous les 500 kilomètres (310 miles)

905B-190413-US13C

Operator Safety

Safety Labels - ZFORCE 950 Sport - 4

7

⚠ WARNING

**R
N
H
L**

- To avoid transmission damage, shift only when vehicle is stationary and at idle.

APPLY BRAKE TO START

- When this vehicle is not in operation or unattended, place shift in the park position.
- Stop the vehicle and apply the Brake before using the Shift Lever, the 2WD/4WD Switch and the Diff Lock Switch.

5BWV-190014-5000 US219

8

⚠ WARNING

Improper loading of a trailer may cause loss of vehicle control, resulting in severe injury or death.

- Maximum unbraked towing mass **1190 lbs. (540 kg)**.
- Maximum unbraked tongue mass **119 lbs. (54 kg)**.

5BYV-190013-9000 EU22B

9

⚠ WARNING

Severe INJURY or DEATH can result if you ignore the following:

- Maximum Load in Cargo Bed: **330lbs(150kg)**.
- Never carry passengers in cargo bed.
- Cargo can affect handling and stability. Read Owner's Manual before loading or towing.
- When loading with cargo or towing a trailer: Reduce speed and allow more room to stop. Avoid hills and rough terrain.
- Be sure cargo is secured a loose load could change handling unexpectedly.
- Keep weight in the cargo bed centered, and as low and far forward as possible. Top heavy loads increase the risk of overturn.



5BWV-190012-5000 US219

Operator Safety

Safety Labels - ZFORCE 950 Sport - 4

10

WARNING

Be prepared in case of rollover. If the vehicle rolls over, any part of your body (such as arms, legs, or head) outside of the cockpit can be crushed by the cage or other parts of the vehicle. Fasten seat belt and make sure net and/or door is securely latched in place to help you avoid sticking out arms or legs.

NEVER hold the cage while riding.

NEVER try to stop a rollover using your arm or leg.

SA5V-190021-6300 U0324

11

WARNING

Be prepared in case of rollover. If the vehicle rolls over, any part of your body (such as arms, legs, or head) outside of the cockpit can be crushed by the cage or other parts of the vehicle. Fasten seat belt and make sure net and/or door is securely latched in place to help you avoid sticking out arms or legs.

NEVER hold the cage while riding.

NEVER try to stop a rollover using your arm or leg.

SA5V-190022-6300 U0324

12

NOTICE

Transmission oil:
Type: 75W/90/GL-5
Oil volume: 0.6L
Capacity change: 0.6L

9AWA-190008 EU179

13

NOTICE

Engine oil:
Type: SAE10W-40 SG or higher
Engine oil volume: 2.6L
Capacity change / no oil filter: 2.4L
Capacity change / oil filter: 2.5 L

9AW#-190007-2410 EU201

14

E₁₃ **CFMOTO**
S100
55R-014195
A50-X D5.12

9GQ0-190006 EU206

15

5BYV-190017-6300 EU232

Operator Safety

Potential Hazard Warnings

WARNING

POTENTIAL HAZARD:

Operating this vehicle without proper instruction.

WHAT CAN HAPPEN:

The risk of an accident is greatly increased if the operator does not know how to operate the vehicle properly in different situations and on different types of terrain.

HOW TO AVOID THE HAZARD:

Beginning and inexperienced operators should complete a safety training course if offered by dealer. Operators should regularly practice the skills learned in the course and the operating techniques described in the owner's manual.

WARNING

POTENTIAL HAZARD:

Failure to follow the age recommendations for this vehicle.

WHAT CAN HAPPEN:

Severe injury and/or death could occur if a child under the minimum age recommendation operates this vehicle. Even though a child may be within the recommended age group for operating, he/she may not have the skills, abilities, or judgment needed to operate safely and could be susceptible to accident or injury.

HOW TO AVOID THE HAZARD:

Driver must be at least 16 years old with a valid driver's license to operate.

Operator Safety

WARNING

POTENTIAL HAZARD:

Carrying more passengers than the rated capacity.

WHAT CAN HAPPEN:

A passenger not seated in the vehicle could be ejected from the vehicle unexpectedly or make contact with moving components, both of which can result in severe injury or death.

HOW TO AVOID THE HAZARD:

Never allow carrying more than one passengers (For ZFORCE 950 Sport-4, only 3 passengers are allowed).

Operator Safety

⚠️ WARNING

POTENTIAL HAZARD:

Operating this vehicle without wearing approved helmet, eye protection, and protective clothing.

WHAT CAN HAPPEN:

Operating without an approved helmet increases the risk of a severe head injury or death in the event of an accident. Operating without eye protection could result in an accident and could increase the chance of a severe eye injury in the event of an accident. Operating without protective clothing could increase the chance of a severe injury.

HOW TO AVOID THE HAZARD:

Always wear an approved helmet that fits properly. Always wear eye protection (goggles or face shield), gloves, long-sleeved shirt or jacket, long pants, and over-the-calf boots.

⚠️ WARNING

POTENTIAL HAZARD:

Operating the vehicle after consuming alcohol or drugs.

WHAT CAN HAPPEN:

Consumption of alcohol and/or drugs could seriously affect operator judgment. Reaction time may be slower and operator balance and perception could be affected. Consumption of alcohol and/or drugs before or while operating a vehicle could result in an accident causing severe injury or death.

HOW TO AVOID THE HAZARD:

Never consume alcohol or drugs before or while operating the vehicle.



Operator Safety

WARNING

POTENTIAL HAZARD:

Operating at excessive speeds.

WHAT CAN HAPPEN:

Excessive speed increases the operator's chance of losing control, which can result in an accident.

HOW TO AVOID THE HAZARD:

Always operate at a speed that's proper for the terrain, visibility and operating conditions, and your experience.

WARNING

POTENTIAL HAZARD:

Attempting slides, jumps, and other stunts.

WHAT CAN HAPPEN:

Attempting stunts increases the chance of an accident, including an overturn.

HOW TO AVOID THE HAZARD:

Never attempt slides, jumps, or other stunts.

Operator Safety

WARNING

POTENTIAL HAZARD:

Failure to inspect the vehicle before operating. Failure to properly maintain the vehicle.

WHAT CAN HAPPEN:

Poor maintenance increases the possibility of an accident or equipment damage.

HOW TO AVOID THE HAZARD:

Always inspect your vehicle before each use to make sure it's in safe operating condition.

Always follow the inspection and maintenance procedures and schedules described in the owner's manual.

WARNING

POTENTIAL HAZARD:

Extending arms, hands, or legs outside the ROPS bars of the vehicle during operation.

WHAT CAN HAPPEN:

Severe injury can occur to arms, hands, or legs if the vehicle overturns or rolls over in an accident.

HOW TO AVOID THE HAZARD:

Always keep arms, hands, or legs inside the vehicle, hands on the steering wheel or hand grip, and keep both feet on the footrests of the vehicle during operation.

Operator Safety

WARNING

POTENTIAL HAZARD:

Failure to use extra caution when operating on unfamiliar terrain.

WHAT CAN HAPPEN:

Unfamiliar terrain may contain hidden rocks, bumps, or holes that could cause loss of control or overturn.

HOW TO AVOID THE HAZARD:

Travel slowly and use extra caution when operating on unfamiliar terrain. Always be alert to changing terrain conditions.

WARNING

POTENTIAL HAZARD:

Turning improperly.

WHAT CAN HAPPEN:

Improper turns could cause loss of control and lead to a collision or overturn.

HOW TO AVOID THE HAZARD:

Always follow proper procedures for turning as described in the owner's manual. Practice turning at slow speeds before attempting to turn at faster speeds. Never turn at excessive speed.

Operator Safety

WARNING

POTENTIAL HAZARD:

Failure to use extra caution when operating on excessively rough, slippery or loose terrain.

WHAT CAN HAPPEN:

Operating on excessively rough, slippery or loose terrain could cause loss of traction or loss of control, which could result in an accident or overturn.

HOW TO AVOID THE HAZARD:

Do not operate on excessively rough, slippery or loose terrain until you've practiced and learned the skills necessary to control the vehicle on such terrain. Always use extra caution on rough, slippery or loose terrain.

WARNING

POTENTIAL HAZARD:

Climbing excessively steep hills or climbing hills improperly.

WHAT CAN HAPPEN:

Improper hill climbing could cause loss of control or overturn.

HOW TO AVOID THE HAZARD:

Never operate on hills too steep for the vehicle or for your abilities. Practice on smaller hills before attempting large hills. Always check the terrain carefully before ascending any hill. Never climb hills with excessively slippery or loose surfaces. Never increase the throttle suddenly while traveling uphill. The vehicle could flip over backwards. Never go over the top of any hill at high speed. An obstacle, a sharp drop, another vehicle, or person could be on the other side of the hill.

Operator Safety

WARNING

POTENTIAL HAZARD:

Traveling down excessively steep hills.

WHAT CAN HAPPEN:

Improper downhill travel could cause loss of control or overturn.

HOW TO AVOID THE HAZARD:

Never operate on hills too steep for the vehicle or for your abilities. Practice on smaller hills before attempting large hills. Always check the terrain carefully before attempting any hill. Never descend hills with excessively slippery or loose surfaces.

NOTE:

Always check the terrain carefully before descending a hill. Never travel down a hill at high speed. Avoid traveling down a hill at an angle. Travel straight down the hill when possible.

Operator Safety

WARNING

POTENTIAL HAZARD:

Improperly crossing hills and turning on hills.

WHAT CAN HAPPEN:

Improperly crossing or turning on hills could cause loss of control or overturn.

HOW TO AVOID THE HAZARD:

Use extra caution when turning on any hill. Avoid crossing the side of a steep hill.

WHEN CROSSING THE SIDE OF A HILL:

Always follow proper procedures as described in the owner's manual. Avoid hills with excessively slippery or loose surfaces.

Operator Safety

WARNING

POTENTIAL HAZARD:

Stalling, rolling backwards while climbing a hill.

WHAT CAN HAPPEN:

The vehicle could overturn.

HOW TO AVOID THE HAZARD:

Maintain a steady speed when climbing a hill.

IF ALL FORWARD SPEED IS LOST:

Close the throttle. Apply the brake. When fully stopped, shift the gear selector to the park position.

IF THE VEHICLE BEGINS ROLLING:

Never apply engine power. Carefully apply the foot brake while rolling backwards. When fully stopped, keep the brake applied, shift the gear selector to the parking position, and determine the best way to safely change direction.

Operator Safety

WARNING

POTENTIAL HAZARD:

Improperly operating over obstacles.

WHAT CAN HAPPEN:

Operating over obstacles could cause loss of control or overturn.

HOW TO AVOID THE HAZARD:

Before operating in a new area, check for obstacles. Avoid operating over large obstacles such as rocks and fallen trees when possible. If unavoidable, use extreme caution and always follow proper procedures as outlined in the owner's manual.

WARNING

POTENTIAL HAZARD:

Skidding or sliding.

WHAT CAN HAPPEN:

Skidding or sliding can cause loss of control. If the tires regain traction unexpectedly, the vehicle could overturn.

HOW TO AVOID THE HAZARD:

On slippery surfaces such as ice, travel slowly and use extra caution to reduce the chance of skidding or sliding out of control.

Operator Safety

WARNING

POTENTIAL HAZARD:

Overloading the vehicle or carrying/towing cargo improperly.

WHAT CAN HAPPEN:

Overloading and towing can cause changes in vehicle handling, which could lead to loss of control or an accident.

HOW TO AVOID THE HAZARD:

Never exceed the stated load capacity for this vehicle.

Cargo should be properly distributed and securely attached. Reduce speed and always use low gear when carrying cargo or pulling a trailer. Allow a greater distance for braking. Always follow the instructions in the owner's manual for carrying cargo or pulling a trailer.

Operator Safety

WARNING

POTENTIAL HAZARD:

Operation the vehicle through deep or fast-flowing water.

WHAT CAN HAPPEN:

Tires may float, causing loss of traction and loss of control, which can lead to an accident or overturn.

HOW TO AVOID THE HAZARD:

Avoid operating through deep or fast-flowing water. If it is unavoidable to enter water that exceeds the recommended maximum depth, travel slowly, balance your weight carefully, avoid sudden movements, and maintain a slow and steady forward motion. Do not make sudden turns or stops, and do not make sudden throttle changes. Wet brakes may have reduced stopping ability. Always test the brakes after leaving the water. If necessary, apply the brakes several times while driving slowly to dry out the pads.

Operator Safety

WARNING

POTENTIAL HAZARD:

Improperly operating in reverse.

WHAT CAN HAPPEN:

The vehicle could collide with an obstacle or person, resulting in severe injury.

HOW TO AVOID THE HAZARD:

Before shifting into reverse gear, always check for obstacles or people behind the vehicle. When it's safe to proceed, back slowly.

WARNING

POTENTIAL HAZARD:

Operating this vehicle with improper tires, or with improper or uneven tire pressure.

WHAT CAN HAPPEN:

Use of improper tires, or operation of the vehicle with improper or uneven tire pressure, could cause loss of control or an accident.

HOW TO AVOID THE HAZARD:

Always use the size and type of tires specified in the owner's manual. Always maintain proper tire pressure.

Operator Safety

WARNING

POTENTIAL HAZARD:

Operating the vehicle with improper modifications.

WHAT CAN HAPPEN:

Improper installation of accessories or modification of the vehicle may cause changes in handling which could lead to an accident.

HOW TO AVOID THE HAZARD:

Never modify the vehicle through improper installation or use of accessories. All parts and accessories added to the vehicle must be genuine parts or equivalent components designed for use on this vehicle, and they should be installed and used according to approved instructions. Consult your dealer for more information.

WARNING

POTENTIAL HAZARD:

Operating on frozen bodies of water.

WHAT CAN HAPPEN:

Severe injury or death can result if the vehicle falls through the ice.

HOW TO AVOID THE HAZARD:

Never operate the vehicle on the frozen water.

Operator Safety

WARNING

Leaving the keys in the ignition can lead to unauthorized use of the vehicle, resulting in serious injury or death. Always remove the ignition key when the vehicle is not in use.

WARNING

After any overturn or accident, have an authorized dealer inspect the entire vehicle for possible damage, including (but not limited to) brakes, throttle and steering systems.

WARNING

Safe operation of this vehicle requires good judgment and physical skills. Persons with cognitive or physical disabilities who operate this vehicle have an increased risk of overturn and loss of control, which could result in severe injury or death.

WARNING

Exhaust system components are very hot during and after use of the vehicle. Hot components can cause serious burns and fire. Do not touch hot exhaust system components. Always keep combustible materials away from the exhaust system. Use caution when traveling through tall grass, especially dry grass.

Controls and Features

ZFORCE 950 Sport

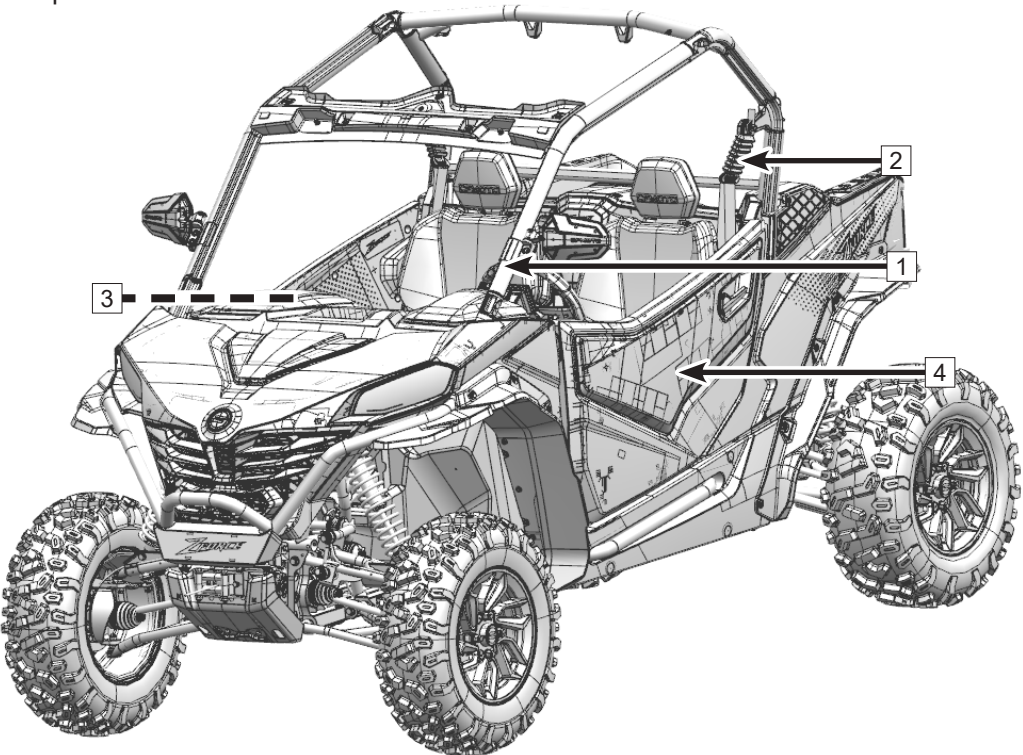

Controls and Features

ZFORCE 950 Sport-4

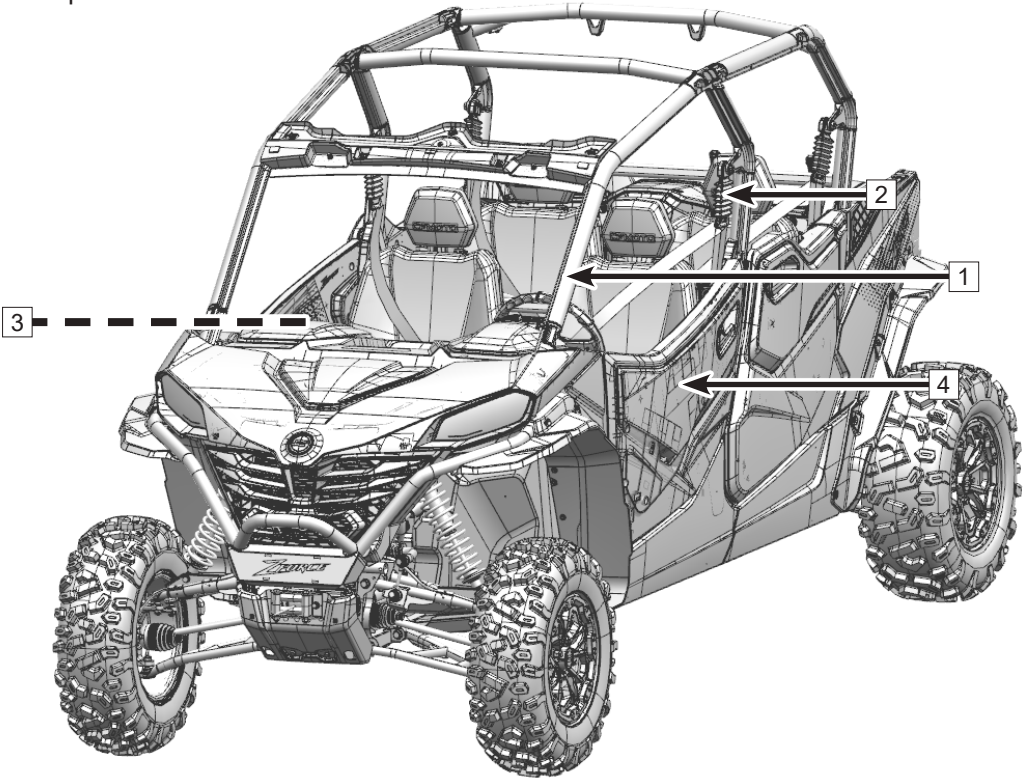

Controls and Features

Occupants Protector

Cab Frame - (1)

This vehicle is equipped with cab frame to help to protect the occupants from injury in case of a rollover or other dangerous situation. Never place any body part outside of the cab frame while the vehicle is moving.

Safety Belt - (2)

This vehicle is equipped with seat belts to help keep occupants in the cab and protect the driver and passenger in the event of a collision, rollover or tip-over. A seat belt indicator light will flash if seat belt is not fastened during driving.

Passenger Handrail - (3)

A handrail is provided in the front of the passenger seat. Holding the handrail allows the passenger to brace against the movement of the vehicle and keep the hands and body inside the cab in case of rollover.

NOTE:

When carrying a passenger, the operator should instruct the passenger to hold the handrail tightly at all times.

Side Door* / Side Net* - (4)

Depending on market, this vehicle is equipped with two side doors or side nets that help to keep arms, legs and shoulders inside the vehicle to prevent possible injury. Always latch side nets or side doors when driving the vehicle. Make sure the side net mounting points are fixed securely on the vehicle and buckle the latch into the lock connector (*Vehicles are equipped with side nets or side doors as standard equipment according to selected market).

Controls and Features

ZFORCE 950 Sport

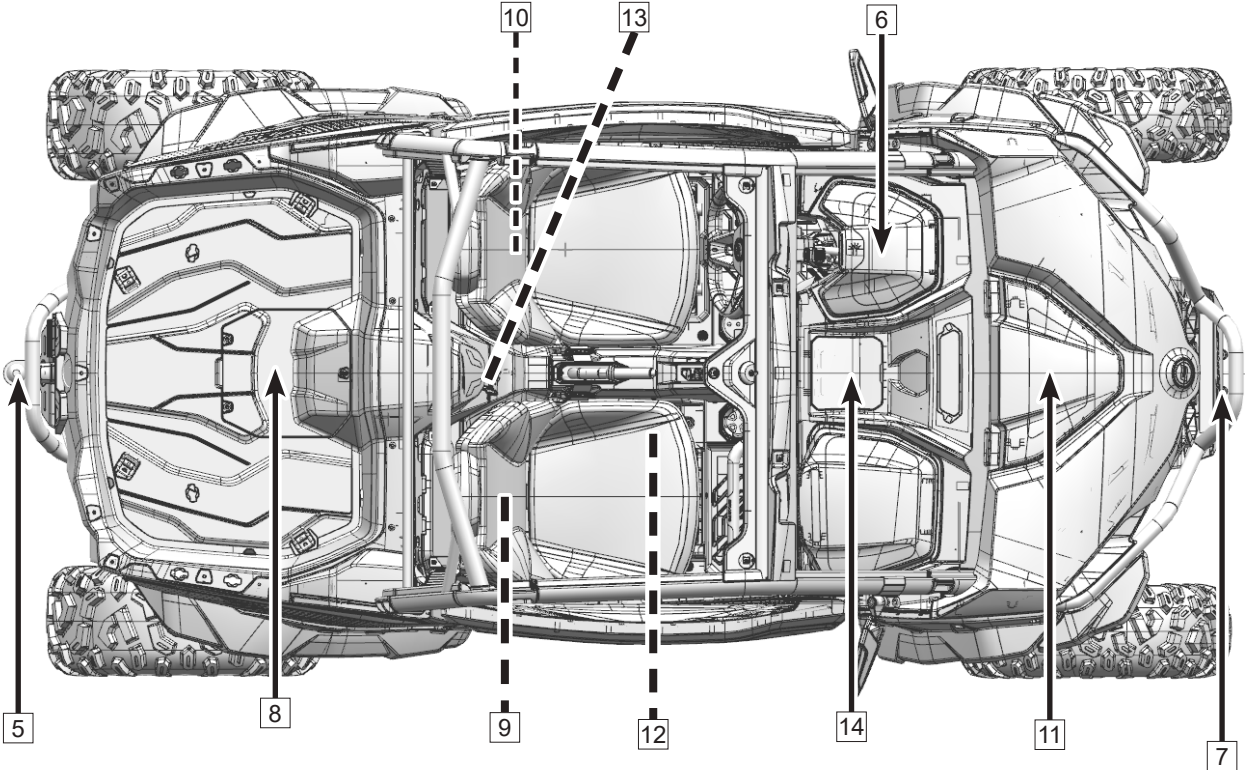

Controls and Features

ZFORCE 950 Sport-4

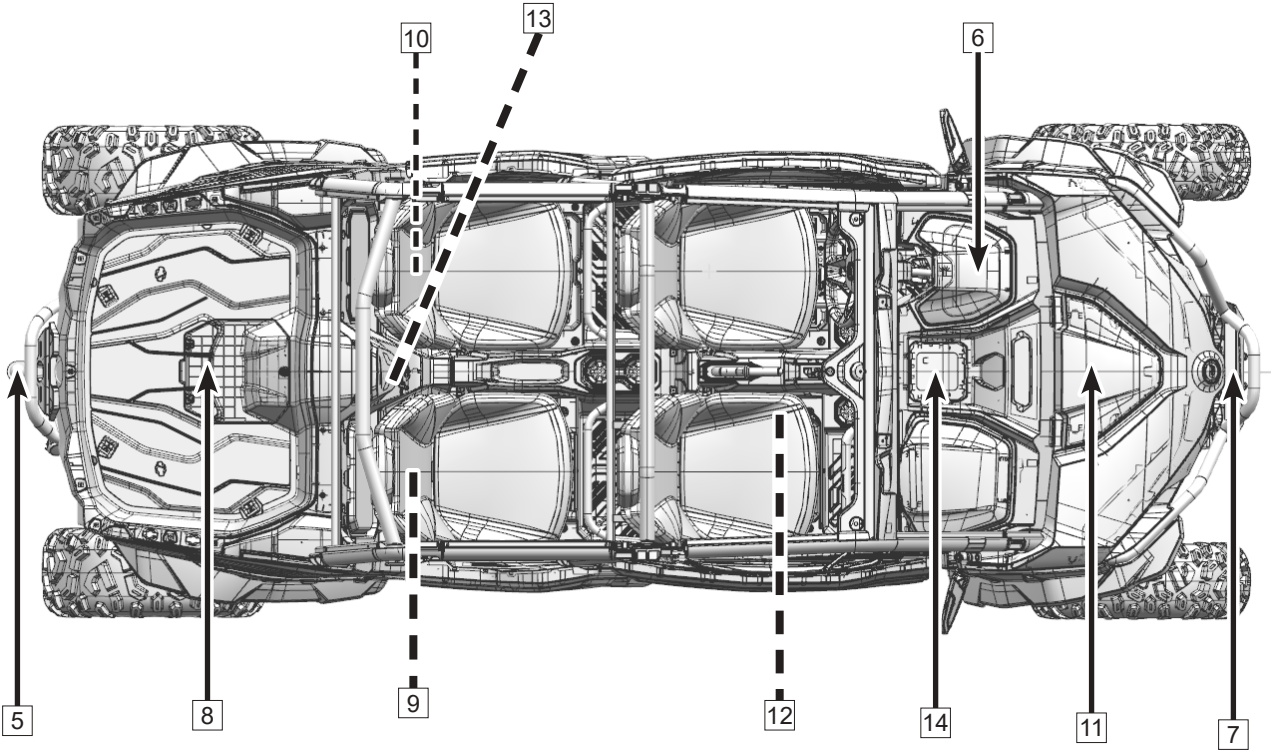

Controls and Features

Hitch and Winch

Hitch - (5)

This vehicle is equipped with a standard size 2 in. × 2 in. (51 mm × 51 mm) hitch receiver. Please consult with your dealer about hitch use and how to use a trailer before operating the vehicle.

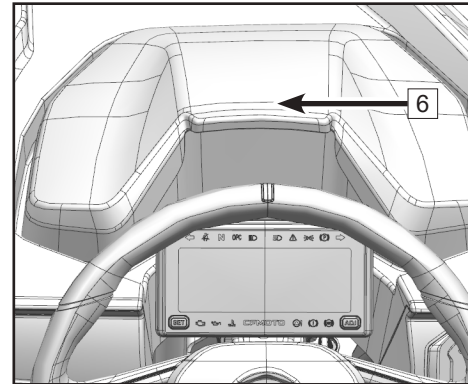

Front Storage Box / Winch Control Socket - (6) (If equipped with the winch)

The winch control socket **2** and USB port **1** are located in the front storage box **6**. Connect the wired winch controller to the winch control switch socket to operate the winch.

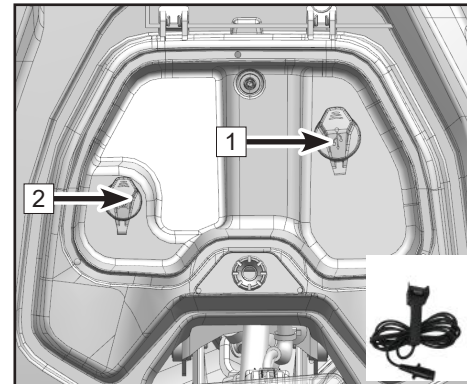

Controls and Features

Winch - (7) (If equipped)

This vehicle is equipped with a 3500-lb. winch (For ZFORCE 950 SPORT-4, it is a 4500-lb winch), with a standard wired controller that is typically stored inside the front storage box. Only operate the winch when engine is running to keep the battery capacity. Read the winch operation section in this manual before operating or consult with your dealer on proper winch use.

Rear Access Cover - (8)

If cargo box cover and mat are equipped, please open the cover and take the mat first.

A rear access cover is provided for inspection of the area at the rear of the engine. With the rear access cover removed, certain parts around the rear of the engine can be inspected or repaired.

Removal: Remove the three bolts **1** on the access cover, pull upward and remove.

Install: Align the cover with the holes, and install the bolts.

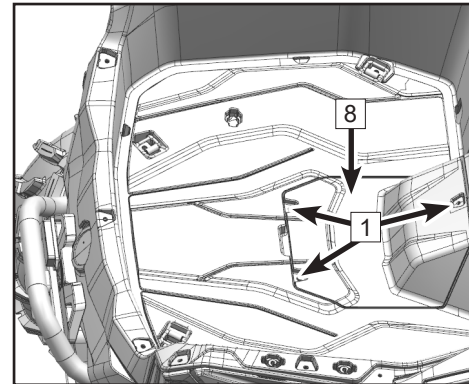

Controls and Features

Air Filter Access Cover - (9)

The air filter access cover is located behind the passenger seat (For ZFORCE 950 SPORT-4, it is behind the right passenger seat in the second row.). Take off the clasps **1**, take out the air filter access cover and the air filter cover, then air filter can be cleaned and serviced.

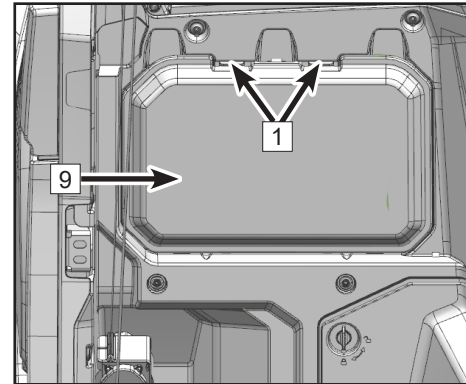

ECU Cover and Service Cover - (10)

The ECU access cover is located behind the driver seat (For ZFORCE 950 SPORT-4, it is behind the left passenger seat in the second row.). With the ECU access cover removed, the ECU, ECU diagnostic port and fuse /relay box can be serviced.

Removal: Move the driver seat forward, pull the seat latch upward and take out the driver backseat (For ZFORCE 950 SPORT-4 vehicles, lift and take out the left passenger backseat in the second row.), then take off the clasps **1**, and remove the ECU cover.

Installation: Align the tabs under the ECU access cover into the holes, press on the clasps **1** upward to secure the ECU access cover.

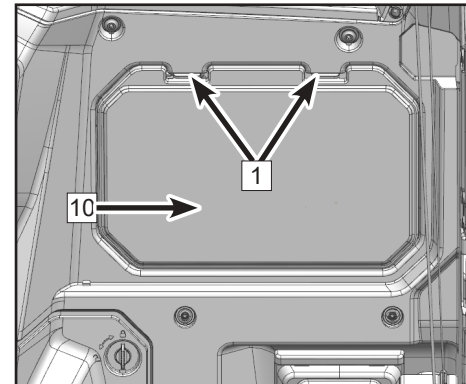

Controls and Features

Front Access Cover - (11)

A front access cover is provided for inspection and maintenance of the radiator assy, reservoir tank, and brake fluid reservoir.

Removal: Grasp the cover edge, then pull upward to release the grommet pins and remove.

Installation: Insert the cover tabs into the corresponding holes on the body, then align the grommet pins and press down.

NOTE:

Maintain easy cover removal by applying a small amount of lubricant to the grommet pins occasionally.

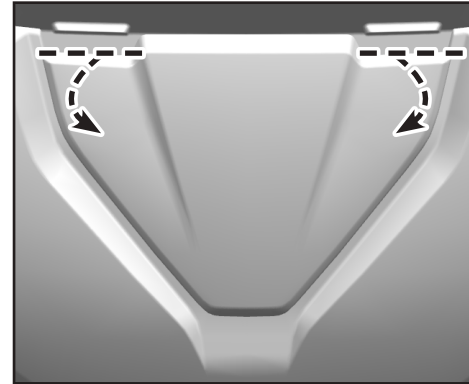

Transmission Access Cover - (12)

When adjustment shift cable adjustment is required for the transmission, remove the passenger seat and transmission access cover.

Removal: Remove the passenger seat (For ZFORCE 950 SPORT-4, remove the passenger seat in the first row and transmission access cover.), take off the clasps **1**, pull upward the transmission access cover.

Installation: Insert the cover tabs into the corresponding holes on the body, then press down the clasps **1** on the transmission cover.

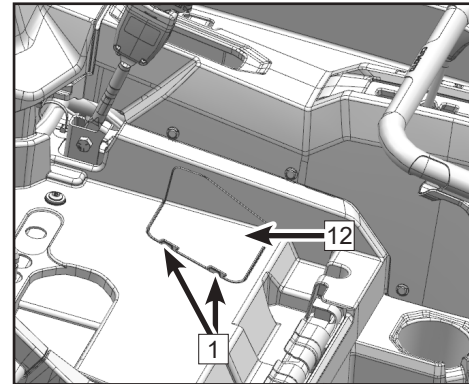

Controls and Features

Front Engine Access Cover - (13)

A front engine access cover is provided for inspection and maintenance of the front engine area and components.

Removal: Remove driver and passenger seat (For ZFORCE 950 SPORT-4, remove two passenger seats in the second row), screw out the knobs on the access cover, then pull up and remove the access cover.

Installation: Insert the cover tabs into the corresponding holes, then install the knobs on the access cover and secure them tightly.

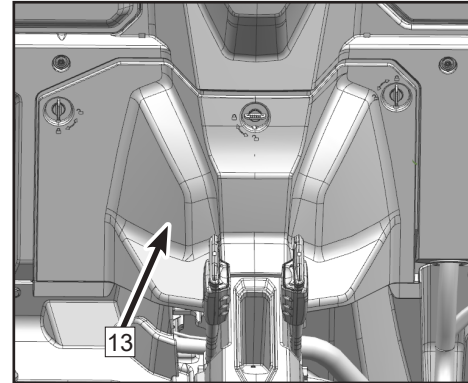

Switch Access Cover - (14)

Switch access cover is located at the middle position between the two front storage boxes. Remove the cover to service switches on the switch panel.

Removal: Pull upward to release the grommet pins, then remove the switch access cover.

Installation: Align and insert the tabs under the access cover into the holes, then align the grommet pins and press.

Maintain easy cover removal by applying a small amount of lubricant to the grommet pins occasionally.

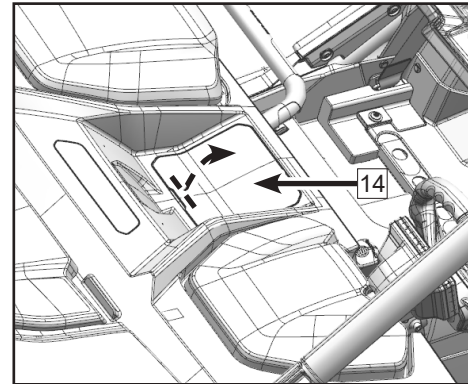

Controls and Features

ZFORCE 950 Sport

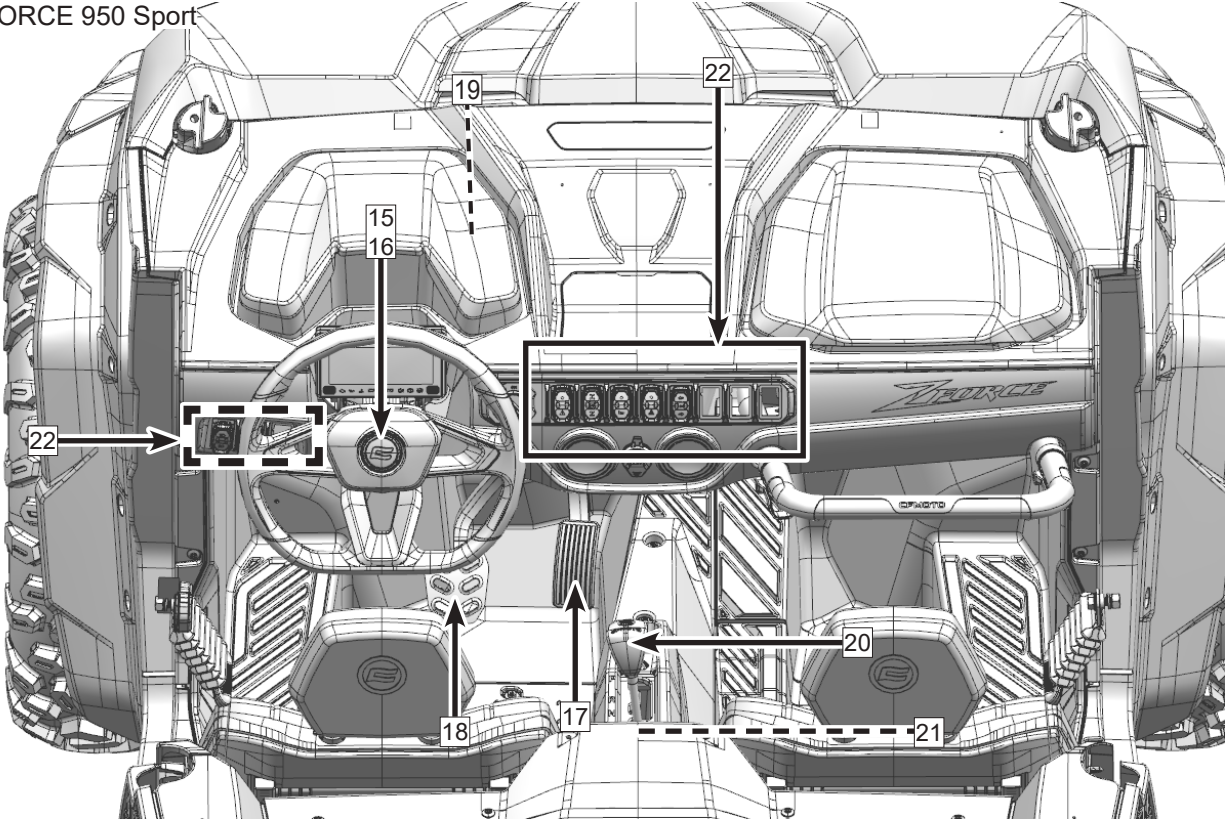

Controls and Features

ZFORCE 950 Sport - 4

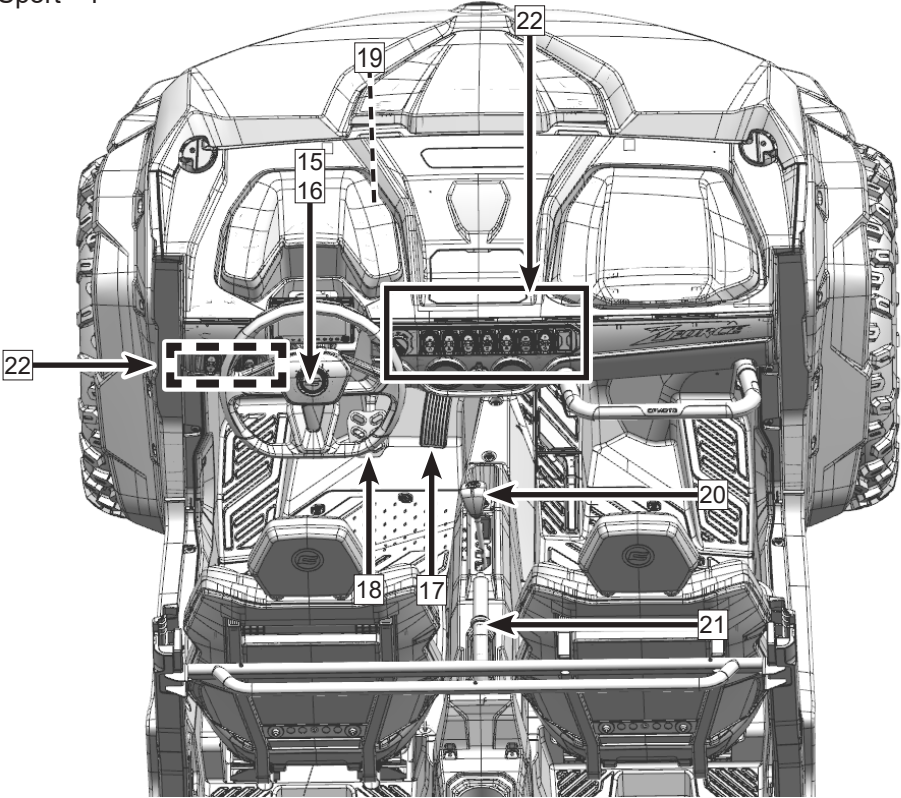

Controls and Features

Primary Controls

Tilt Lever and Steering Wheel Lock - (15)

A tilt lever feature allows the steering wheel to be adjusted to fit the operator. Pull up the lever and adjust the steering wheel tilt angle for comfort. Push down the lever to lock the steering wheel tilt angle.

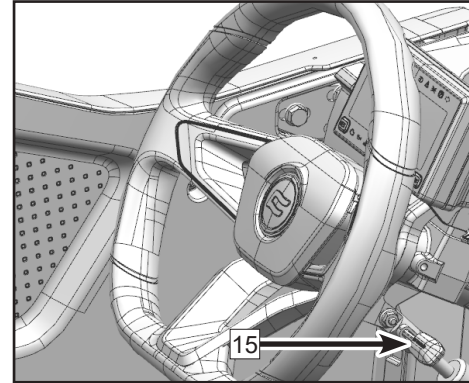

Steering Wheel - (16)

The steering wheel is located in front of the driver's seat. Use the steering wheel to turn the vehicle left or right to the desired direction of travel.

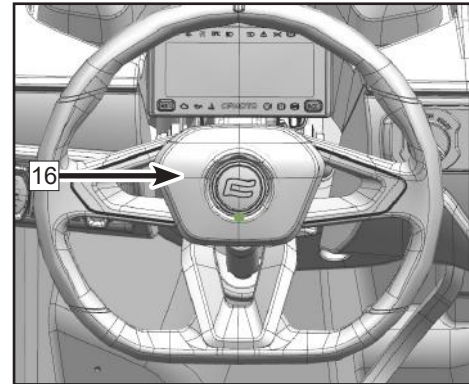

Controls and Features

Electronic Throttle Pedal - (17)

The electronic throttle pedal is located to the right of the brake pedal. The throttle pedal controls engine rpm and vehicle speed by pressing the pedal with your right foot. Always check the pedal function before driving.

The electronic throttle system has the following functions:

1. Start-in-gear protection function: The vehicle engine can start directly in Neutral and Park, The foot brake must be applied to start the engine if the transmission is in Low or High gear.
2. Reverse speed limit function: The vehicle speed is limited to 15 mph (25km/h) while operating in reverse gear.
3. Idling function: When the vehicle is in Neutral, engine RPM is limited to 5000rpm.
4. Brake priority function: When the driver applies both brake pedal and throttle pedal at the same time, the electronic throttle body will close. The engine returns to idle automatically until the brake and/or throttle are released.
5. Limp home function: If a fault of the electronic throttle body or throttle pedal is detected, the system will enter into torque limitation or limp home mode. If a fault occurs in the electronic throttle body, the engine will enter into torque limitation and RPM return to idling state. If a fault occurs in the electronic throttle pedal, the vehicle will enter into limp home mode and top engine speed will be less than 5000 rpm.

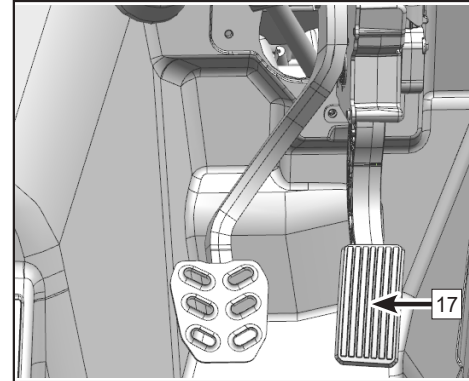

Controls and Features

Brake Pedal - (18)

The brake pedal is located at the left side of throttle pedal. Release throttle pedal and apply brake pedal to reduce speed or stop the vehicle.

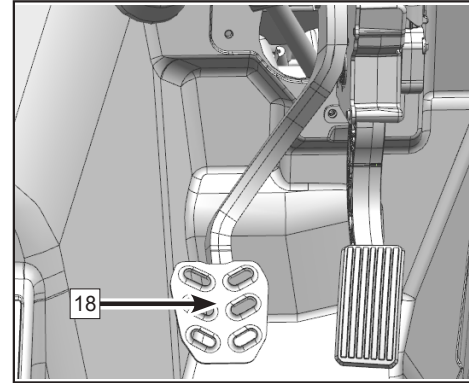

CFMOTO RIDE App and Intelligent Vehicle Terminal Box - (19) (If equipped)

CFMOTO vehicle is equipped with an intelligent vehicle terminal box located at the rear of the front storage box. It builds a communication bridge between the owner and vehicle through the CFMOTO RIDE APP installed on the owner's cell phone. Please contact your dealer about the availability of the CFMOTO RIDE APP in the market you reside.

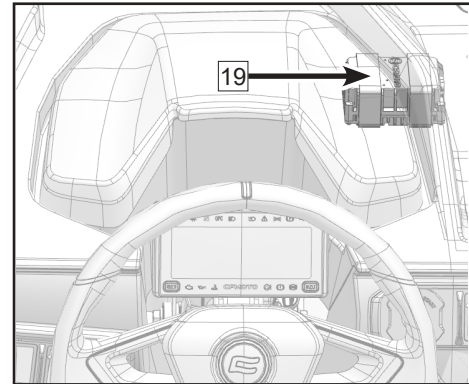

Controls and Features

Gear Shift Lever - (20)

The gear shift lever is located to the right of the driver seat. It is used for changing the transmission gear selection:

When shifting gear, the throttle should be closed and the vehicle should be stopped. Please do not shift gear when the vehicle is running.

L – Low Gear. The low speed range of the gearbox. It allows the vehicle to move slowly with maximum torque at the wheels. Use when constant driving speeds will be under 19 mph (30 km/h)

CAUTION: To avoid damage to the CVT system, always use low gear for constant slow speed travel, to pull a trailer, to carry heavy cargo, to go over obstacles, or to drive up and down hills.

H – High Gear. The high speed range of the gearbox. It allows the vehicle to reach its maximum speed. Use when constant driving speeds will be over 19 mph (30 km/h).

N – Neutral. In neutral position the engine power output is disengaged.

R – Reverse. The reverse gear position allows the vehicle to go backwards. The top speed is limited to 15 mph (25km/h) in reverse.

P – Park. The park position locks the gearbox to help prevent vehicle movement.

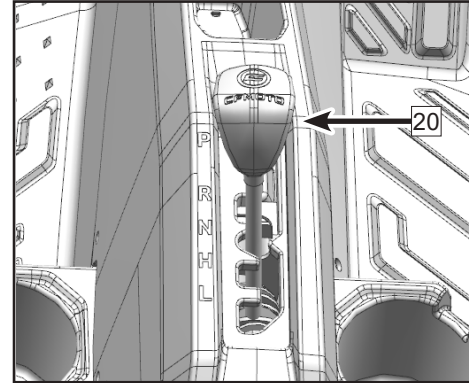

Controls and Features

NOTE:

In reverse operation, the engine's RPM is limited, thus limiting the vehicle speed to approximately 15 mph (25 km/h).

 WARNING

Use extreme caution driving downhill in reverse. Gravity can increase the vehicle speed above the set limited reverse speed.

 WARNING

Always shift to PARK (P) position when the vehicle is not in operation. The vehicle can roll if the shift lever is not set to 'P'. Always use the auxiliary hand brake as an additional precaution to prevent vehicle movement.

Controls and Features

Hand Brake - (21)

This vehicle is equipped with an auxiliary hand brake, which is located to the rear of the gear shifter. Pull the lever back to apply the rear brakes and prevent the vehicle from rolling when parked on an incline.

To release the hand brake, pull the handle lever slightly and depress the release button on top of the level, then push the lever to its original position.

CAUTION

Never depend on the transmission parking feature alone if the vehicle is parked on a hill. Always apply the hand brake and block the wheels on the downhill side of the vehicle to prevent movement. It is recommended to park the vehicle on level ground.

Make sure the hand brake is released before driving the vehicle. Driving without releasing hand brake will lead to wearing of brake pads, causing damage to the brake disc and result in a failure of the brake system.

When the vehicle is moving and the hand brake isn't released completely, the speed will be limited to 7 mph (10 km/h).

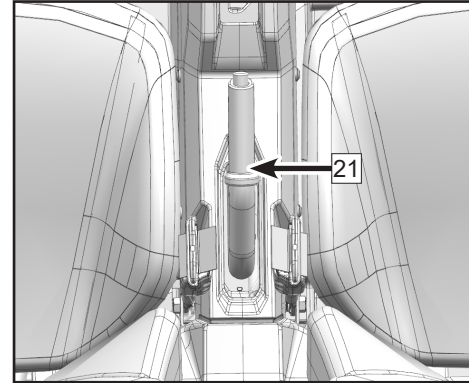



Controls and Features

Secondary Controls

Switch Panel - (22)

Dimmer Switch



Dimmer switch consists of two positions, apply the related switch according to following function selection:

	When the switch is on this position, high beam activates.
	When the switch is on this position, low beam activates.

⚠ CAUTION

Do not use the headlights with the engine turned off for more than 15 minutes. The battery may discharge to a point that the starter motor will not operate properly. If this should happen, remove the battery and recharge it.

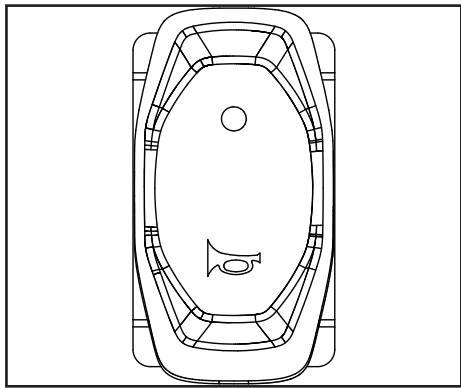
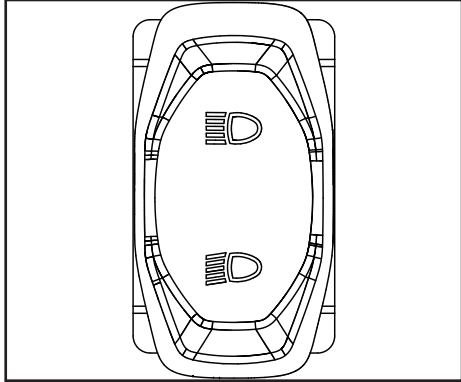

Horn Switch

	Press and hold the momentary switch to sound the horn.
	When the switch rebounds back to this position, the horn will not sound.



Controls and Features

Hazard Switch

	<p>When the switch is on this position, front and rear turning light will flash. The hazard switch indicator light in the dashboard will be on.</p>
	<p>When the switch is on this position, front and rear turning light will stop flashing. The hazard switch indicator light in the dashboard will be off.</p>

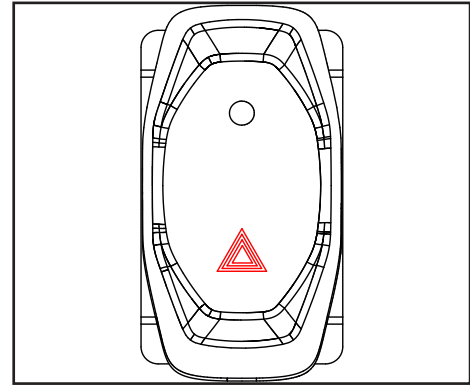

Mode Switch:

<p>NORM</p>	<p>When the switch is on this position, the vehicle is in 'NORM' mode, The dashboard display also shifts to 'NORM' mode. The vehicle will have a less aggressive throttle response for smooth starts and is intended for flat trails, hard pack ground, etc. Use for light-duty riding.</p> <p>NOTE: Do not use this mode for driving situations that place high load on the CVT belt. Damage may occur.</p>
<p>SPORT</p>	<p>When the switch is on this position, the vehicle is in 'SPORT' mode. The dashboard display also shifts to 'SPORT' mode. The vehicle will have a faster throttle response, use for sport riding in sand, mud, or hilly terrain. This mode is the default mode of this vehicle.</p>

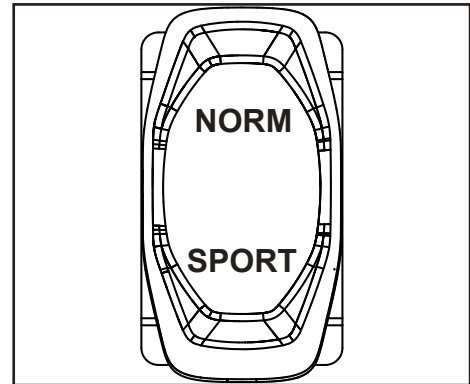



Controls and Features

Secondary Controls

Main Light Switch

The main light switch consists of 3 positions. Turn the switch to select the following functions:

	When the switch is on this position, head light, position light, tail light and instrument light are 'on'.
	When the switch is on this position, position light / tail light will be 'on' and head light will be 'off'.
	When the switch is on this position, all the lights are turned off.

Note:

Ignition key must be turned to 'ON' position before operating head lights. More vehicle lights are used, the dashboard displays with higher brightness.

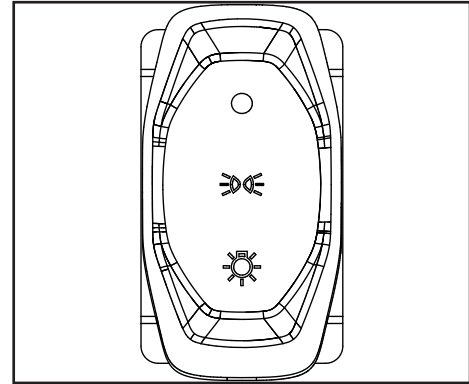

 CAUTION
Do not use the headlights with the engine turned off for more than 15 minutes. The battery may discharge to a point that the starter motor will not operate properly. If this should happen, remove the battery and recharge it.



Controls and Features

2WD / 4WD Switch

This vehicle is equipped with an on-command “2WD”/”4WD” and front diff-lock “LOCK”/”4WD” switch on the dashboard. Select the appropriate drive mode according to terrain and conditions:

	2WD - When the switch is on this position, power is supplied to the rear wheels only.
	4WD - When the switch is on this position, power is supplied to the rear wheels, and to the front wheels.
	4WD-LOCK - When the switch is on this position, power is supplied to the rear and front wheels and the front differential is locked. Unlike 4WD mode, all the wheels turn at the same speed.

 **CAUTION**

The vehicle must be stopped to engage or disengage 2WD/ 4WD and 4WD-LOCK. Mechanical damage may occur if the switch is engaged or disengaged while driving.

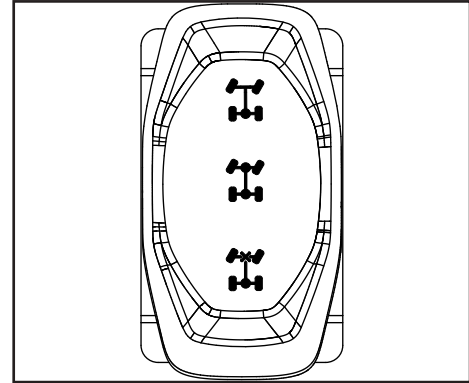

Controls and Features

NOTE: 4WD-LOCK OPERATION:



Steering will require greater effort in 4WD-LOCK mode.

When the switch is set to “LOCK”, the front diff-lock indicator light will flash until the front differential is locked. If the indicator light is flashing, turning the steering left and right will help the front gear locking mechanism to engage.

Riding before the front differential lock is properly engaged (including when the indicator light is flashing) will cause damage for differential locking device, and unable to transmit power properly.

Turning Light Switch

Turning light switch consists of 3 positions, choose the related switch according to below functions:

	When the switch is on this position, left turning light flashes.
	When the switch is in this position, right turning light flashes.
	When the switch is in this position, turning light is off.

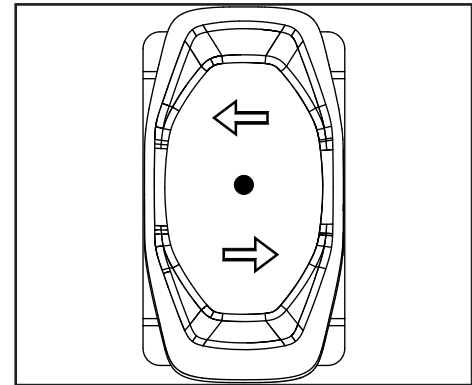

Controls and Features

ZFORCE 950 Sport



Controls and Features

ZFORCE 950 Sport - 4

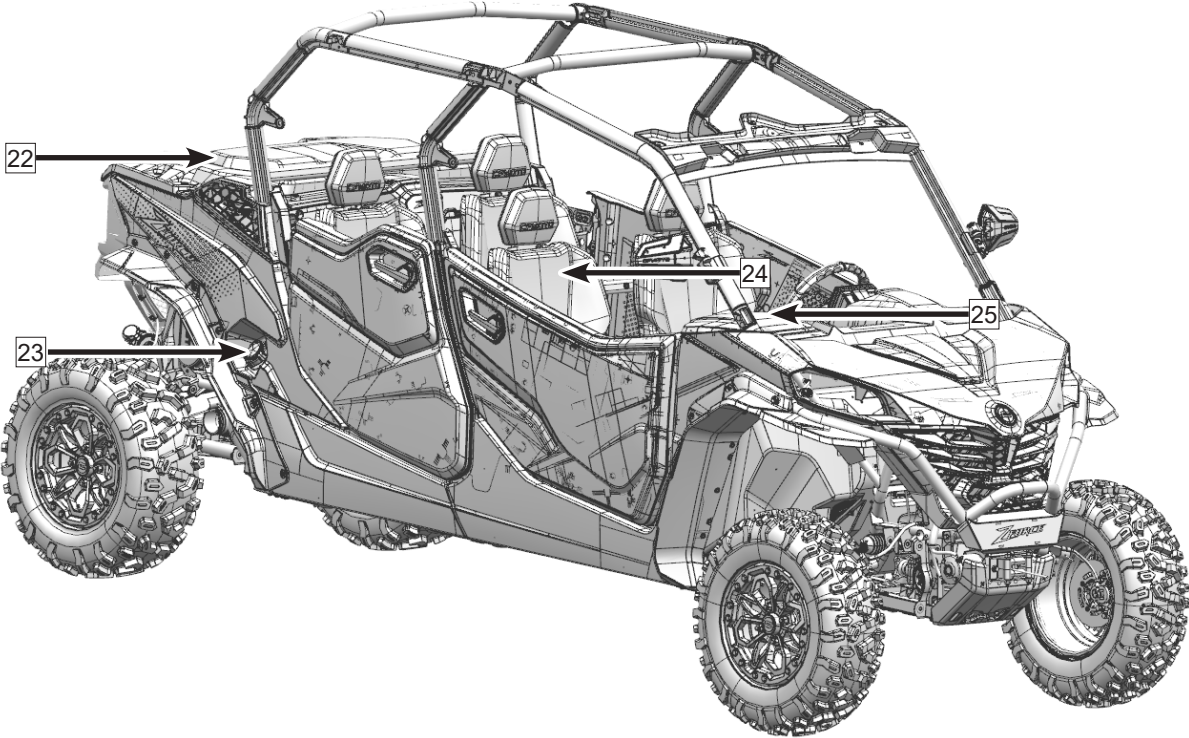

Controls and Features

Other Functions

Cargo Box - (22)

This vehicle has a cargo box with cover for drivers to carry a few objects. This can reduce the impacts on cargo brought by severe climate and prevent cargo from being lost on bumpy roads.

Fuel Filling Cap - (23)

The fuel filling cap is located at the side of passenger seat, near the seat. Before filling with fuel, grip and turn the cap in anticlockwise direction to remove it. Reinstall the fuel filling cap after filling fuel. Fuel tank volume is 9.77 gallons (37 L).

Driver Seat - (24)

The driver's seat offers fore and aft adjustment. To adjust the seat, turn the lever to unlock it. Release the lever to lock the seat into the desired position.

Passenger's seats can be removed easily (For ZFORCE 950 SPORT-4 vehicles, only the passenger's seats in the second row can be removed in a fast way.) There is a handle at the back of the cushion bottom, and pull the handle will cause the cushion to be released and then the seat can be removed.

The driver's seat can not be removed in a fast manner, and when there is a need to check ECU, the driver's backseat can be removed (For ZFORCE 950 SPORT-4 vehicles, the left passenger's backseat in the second row can be removed.) Release the grommet pin from the rubber structure, then pull up to remove the backrest.

Tool Kits - (25)

The tool kits are located at the storage box in front of the passenger seat. Use for vehicle daily maintenance and service.

Controls and Features

CVT System

This vehicle has a Continuously Variable Transmission (CVT) system that utilizes a drive belt and clutch pulleys to automatically vary transmission drive ratios, allowing infinite variability between the highest and lowest vehicle speeds with no discrete steps or shifts.

The CVT system consists of a primary clutch (1), which is an advanced form of centrifugal clutch that is mounted to the engine crankshaft (A).

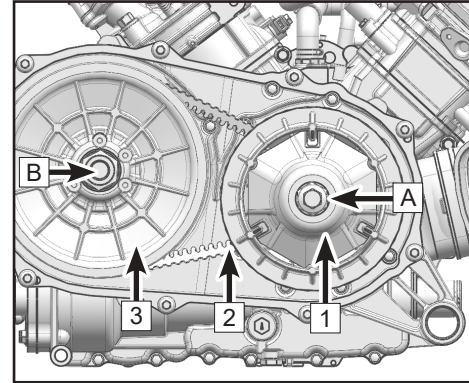

The secondary clutch (3) is mounted to the input shaft of the transmission (B) and serves two functions. As a “slave” pulley to the primary clutch, and to provide a torque sensing element that shifts drive ratios. The drive belt (2) is a heavy duty V-belt that connects the engine and transmission clutch pulleys.

A CVT housing and cover encloses the clutches and belt assembly. There are inlet and outlet cooling ducts that route air to cool the components, and they should be regularly inspected. The CVT components do not contain any user maintenance items. Contact your dealer for service.

Controls and Features

Avoiding CVT Drive Belt and Clutch Failures

CVT clutch and belt life can be dramatically extended by avoiding these common operating mistakes:

Causes CVT damage:	Solution:
Attempting to load the vehicle onto a truck bed or tall trailer in high gear.	Shift transmission to low gear during loading of the vehicle to prevent belt burning.
Starting out on a steep incline in high gear.	When starting out on steep inclines, use low gear.
Constant driving at low RPM, driving at just above clutch engagement RPM, or at low speed (approximately 3mph ~ 7mph [5km/h ~ 10km/h]) in high gear.	Low gear is highly recommended for cooler CVT operating temperatures and longer component life. Drive at a higher speed or use low gear more frequently.
Insufficient warm-up of CVT exposed to low ambient temperatures.	Warm the engine before driving, the CVT drive belt will become more flexible and prevent belt burning.
Slow throttle and easy CVT engagement.	Use the throttle with purpose and effectively for efficient CVT clutch engagement.
Towing / pushing at low RPM/low ground speed.	Use low gear only.
Utility use / plowing snow, dirt, etc.	Use low gear only.
Heavy vehicle load operating at low speed	Use low gear only.

Controls and Features

Causes CVT damage:	Solution
Stuck in mud or snow.	Shift the transmission to low gear, and carefully use fast, aggressive throttle application to engage CVT. ⚠️WARNING: Excessive throttle may cause loss of control and vehicle overturn.
Climbing over large objects from a stopped position.	Shift the transmission to low gear, and carefully use fast, brief, aggressive throttle application to engage the CVT. ⚠️WARNING: Excessive throttle may cause loss of control and vehicle overturn.
Belt slipping from water or snow ingestion into the CVT system.	Drain the water from the CVT housing and dry the CVT if possible, or contact your dealer.
Overheating of the CVT components causes malfunction.	Contact your dealer for inspection and repair of the CVT components.

Note:

Low gear is the preferred transmission gear selection for following situation:

- Constant driving at speed lower than 19 mph (30 km/h).
- Driving in level ground with cargo load or towing load higher than 584 lb. (265 kg)
- Driving in rough or muddy ground with cargo load or towing load higher than 430 lb. (195 kg).

Controls and Features

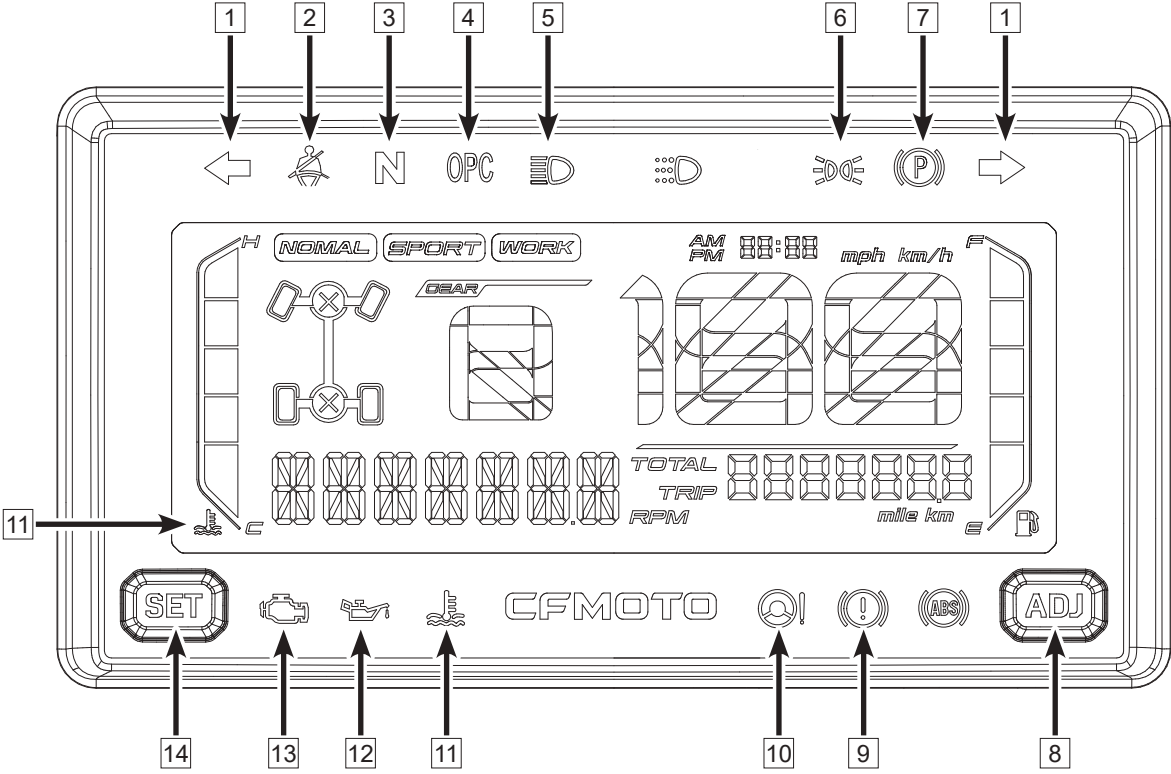

Controls and Features

Dashboard Indicators and Warnings

1	Turning light	6	Position Light Indicator	11	Coolant temp. warning indicator
2	Seat belt warning indicator	7	Parking brake indicator	12	Oil pressure indicator
3	Neutral indicator	8	ADJ - mode adjust button	13	EFI fault indicator
4	OPC indicator	9	Brake fault warning indicator	14	SET - mode select button
5	High beam Indicator	10	EPS indicator		

Controls and Features

Indicators and Warnings

1. Turning Light

When switch turns to right turning light position, the right turning indicator will be on.

When switch turns to left turning light position, the left turning indicator will be on.

2. Seat belt Warning Indicator

Seatbelt Reminder. This indicator displays when the seat belt is not fastened. The latch plate is not pushed securely into the buckle, the indicator on the dashboard is on.

3. Neutral indicator

This indicator displays when the transmission is in neutral.

4. OPC Indicator

When the driver leaves the seat without shifting to the parking position, this indicator will be on and alarm sounds.

5. High Beam Indicator

This indicator illuminates when the headlight switch turns to high beam position.

6. Position Light Indicator

This indicator illuminates when the vehicle is powered on.

7. Parking Brake Indicator

This indicator displays when parking brake function is activated.

Controls and Features

8. ADJ - Mode Adjust Button

Use this key together with SET key to set the information on dashboard.

9. Brake Fault Warning Indicator

This indicator displays when brake fluid level is very low. Add DOT4 brake fluid and contact your dealer. Low brake fluid level may lead to air in the brake system, causing brake fault and lead to serious accident.

10. EPS Indicator

The indicator will be on when a fault occurs in the Electronic Power Steering system. Please stop the vehicle and contact your dealer to eliminate the fault soon. Continue to operate may lead to permanent damage to the EPS system and increasing the turning force.

11. Coolant Temperature Warning Indicator

Both over-low and over-high of the coolant temperature are abnormal. Idle the vehicle to warm the engine when it's too cold, and park the vehicle when it's too hot to prevent the coolant from boiling. Keep the coolant temperature in a normal range.

12. Oil Pressure Indicator

The oil pressure indicator is on when the oil pressure is very low. Please have your vehicle stopped safely at once when the indicator is on, and contact your dealer.

13. EFI Fault Indicator

This indicator displays when a fault occurs in the Electronic Fuel Injection system. Please stop the vehicle and contact your dealer to eliminate the fault. Continue to operate the vehicle may lead to serious damage to the engine.

Controls and Features

14. SET - Mode Adjust Button

Use together with “ADJ” key to adjust functions on the dashboard.

Controls and Features

Dashboard Indicators and Warnings

15	Drive Mode	18	Fuel gauge / Low fuel indicator	21	Engine RPM
16	Clock	19	Rider Information Center		
17	Speed display	20	Gear position display		

Controls and Features

15. Drive Mode

Displays the current drive mode, there are three modes, 2WD, 4WD and 4WD-LOCK.

16. Clock

Display the current time. This dashboard section can be adjusted to correct time by using the “ADJ” and “SET” button.

17. Speedometer

Display the current vehicle speed. Speedometer section can be toggled to display the vehicle speed in Kilometers per hour (km/h) or Miles Per Hour (MPH) by the “ADJ” and “SET” keys.

18. Fuel Gauge / Low Fuel Indicator

Display the fuel level in the fuel tank.

19. Rider Information Center

This dashboard section can be toggled using the ‘SET’ button to display: ‘ODO’ -The accumulated vehicle distance traveled in miles/kilometers, ‘TRIP’ - The trip distance traveled, ‘H’ - The accumulated engine run time, - EFI fault code, ‘V’ - Battery voltage, ‘Brightness’ - Set the dashboard display brightness using the ‘ADJ’ button, - EPS fault code.

20. Gear Position Display

Display the current vehicle gear position.

21. Engine RPM

Indicate the engine current RPM, keep the RPM away from the red area.

Controls and Features

Dashboard Navigation / Settings / Adjustments

Item	Display	SET	ADJ	Operation	Result
Odometer	TOTAL	Short press		Shift to trip	TRIP
Trip	TRIP	Short press		Shift to engine hour	Engine hour
Trip	TRIP		Long press	Trip resets to be zero	TRIP
Engine hour	Engine hour H	Short press		Shift to be fault code	EFI fault code
EFI fault code	EFI fault code	Short press		Shift to voltage	Voltage
Voltage	Voltage U	Short press		Shift to dashboard brightness	Brightness
Dashboard brightness	Dashboard brightness	Short press		Odometer	Odometer
Home interface	Home interface	Long press		Shift to time format setting	Hour setting interface
			Short press	Adjust dashboard brightness	Home interface
Time setting, time format shifting, speed unit shifting	Hour setting	Short press		Shift into time setting	Minutes setting interface
			Short press	Hour number adds 1 by every press	Hour setting interface
			Long press	Hour number increases	Hour setting interface
	Minute unit	Short press		Shift to time unit	12/24 time unit interface
			Short press	Minute number adds 1 by every press	Minute setting interface
			Long press	Minute number increases	Minute setting interface
	12/24 time unit interface	Short press		Shift to unit setting interface	Speed unit setting interface
			Short press	Shift to time format	12/24 time unit interface
	Unit setting interface	Short press		Back to main interface	Home interface
			Short press	Shift to speed unit	Speed unit interface

Operating Your Vehicle

Break-In Period

The break-in period for a new engine is very important. Careful treatment of a new engine at the beginning of ownership will result in more efficient performance and longer life. Perform the following procedures carefully:

1. Select an open area that allows room to familiarize yourself with vehicle operation and handling.
2. Place the vehicle on a level surface.
3. Fill the fuel tank with gasoline.
4. Check the engine oil level. Add the recommended oil if necessary to maintain the oil level between the minimum and maximum indicators on the dipstick.
5. Position yourself in the operating position on the vehicle, fasten the seatbelt and safety nets or side doors, and start the engine. Allow the engine to idle for a short period before operating.
6. Press the foot brake, select the desired gear, and then release the foot brake.
7. Apply throttle. Drive slowly at first, varying throttle positions not more than $\frac{1}{2}$ throttle for 10 hours or 100 miles, then another 10 hours or 100 miles of not more than $\frac{3}{4}$ throttle (whichever interval arrives first). Do not operate at sustained idle or sustained wide open throttle.
8. Do not pull or carry any heavy loads during the break-in period.
9. Periodically check coolant level, controls, etc. Along with the items outlined in the periodic maintenance chart.
10. At the end of the break-in period, change the oil and filter (20 hours or 200 miles / 320 km).

Operating Your Vehicle

⚠ CAUTION

During the 20-hour break-in period:

- Do not operate at sustained full throttle. Damage to engine parts or decrease engine life may result if excessive wide open throttle is used during the first 20 hours of use.
- Do not run engine with throttle over 1/2 open during the first 10 hours (or 100 miles/160km) of use.
- Do not run engine with throttle over 3/4 open during the first 10 to 20 hours (or the second 100 miles/160km) of use.
- Do not haul or tow heavy cargo.
- Use of any oil other than those recommended may cause serious engine damage. CFMOTO recommends the use of 10W-40 SJ or higher for 4-stroke engines. Changing engine oil viscosity to 5W-40 SJ or higher due to extreme cold environments or 15W-40 SJ or higher due to hot environments is acceptable. Reference the chart below for ambient temperature and viscosity choice.

Recommended Engine Oil Viscosity

Oil Viscosity				15W-40				
				10W-40				
				5W-40				
F°	-22	-4	14	32	50	68	86	104
C°	-30	-20	-10	0	10	20	30	40

Operating Your Vehicle

Pre-Ride Inspection

Before each use of the vehicle, a best practice is to check the vehicle according to the “Perform daily before operating the vehicle” checklist in the maintenance section of this manual.

 **WARNING**

If a proper inspection is not done before each use, severe damage to the vehicle, severe injury, or death could result. Always inspect the vehicle before each use to ensure it is in proper operating condition.

Throttle

Before starting the engine, check the throttle pedal to be sure it is operating smoothly. Make sure it returns to the idle position as soon as the pedal is released. Regulate the speed of the vehicle by varying the throttle position. Because the throttle pedal is an electrically operated mechanism controlled by an ECU, the vehicle will decelerate and the engine should return to idle speed any time your foot is removed from the throttle pedal.

Operating Your Vehicle

Foot Brake

Before operating the vehicle, push down on the pedal to apply the front and rear brakes. When pressed, the lever or pedal should feel firm. A soft brake pedal would indicate a possible fluid leak or low master cylinder fluid level, which must be corrected before riding. Contact your dealer for proper diagnosis and repairs.

Starting the Engine

 WARNING
--

Never run an engine in an enclosed area. Engine exhaust contains poisonous carbon monoxide and can cause loss of consciousness, resulting in severe injury or death.

Starting a Cold Engine

1. Verify the gear selector is shifted to the Parking or Neutral position.
2. Apply the foot brake.
3. Turn the master key to ON "".
4. Verify the throttle is completely closed, then turn the key start switch.
5. Once the engine starts, continue to warm the engine for a short period before operating the vehicle.

Operating Your Vehicle

NOTE:

Do not activate the starting system more than 10 seconds on each attempt. If the engine fails to start, release the start switch, pause a few seconds before the next attempt, then try the start switch again. Each attempt should be as short as possible to preserve battery energy.

The engine can only be started when the vehicle is at the neutral gear or parking gear. If the neutral indicator light on the dashboard does not come on when the gear selector is in the neutral position, contact your dealer to inspect the indicator electrical circuit or adjust the gear shifting system.



Allow the engine to warm up for a short period before operating the vehicle. Operating the vehicle immediately after starting could cause engine damage.

Shifting the Transmission



To avoid transmission damage, return the throttle to the closed position, stop the vehicle, and apply the foot brake before shifting.

NOTE:

Low gear is the preferred transmission gear selection for all forward motion other than prolonged high speed travel.

Operating Your Vehicle

Shifting Out of Park

1. Verify the throttle is closed.
2. Apply the foot brake and press the gear selector button.
3. Shift to the desired gear by moving the gear selector along the shift guide.

Shifting: Neutral to High Gear

1. Verify the throttle is closed and the vehicle is stopped completely.
2. Apply the foot brake.
3. Shift to 'H' by moving the gear selector along the shift guide.

Shifting: High Gear to Low Gear

1. Verify the throttle is closed and the vehicle is stopped completely.
2. Apply the foot brake.
3. Shift to 'L' by moving the gear selector along the shift guide.

Operating Your Vehicle

Shifting: Low Gear to High Gear

1. Verify the throttle is closed and the vehicle is stopped completely.
2. Apply the foot brake.
3. Shift to 'H' by moving the gear selector along the shift guide.

Shifting: to Reverse Gear

1. Verify the throttle is closed and the vehicle is stopped completely.
2. Apply the foot brake and press the gear selector button.
3. Shift to 'R' by moving the gear selector along the shift guide.
4. Check behind you for people or obstacles, then release the rear brake pedal.
5. Apply the throttle lever gradually and continue to watch behind you while moving backward.

Operating Your Vehicle

WARNING

Before shifting into reverse, make sure there are no obstacles or people, and the area is safe behind you. When it is safe to proceed, go slowly.

Avoid excessive throttle operation while in speed limit mode, as it may cause fuel to build in the exhaust, resulting in engine popping and/or engine damage.

Shifting: to Park

1. Verify the throttle is closed and the vehicle is stopped completely.
2. Apply the foot brake and press the gear selector button.
3. Shift to 'P' by moving the gear selector along the shift guide. Shake the vehicle forward and backward to verify that parking is engaged.

NOTE:

- The gear shift indicators should display corresponding to the actual gear position, if the indicator does not display, ask your dealer to inspect the vehicle electrical circuit or adjust the gear shifting system.
- Due to the synchronizing mechanism in the engine, an indicator may not display until the vehicle starts moving.
- Do not use high gear for continuous slow speed travel or towing, as this can lead to excessive heating of the clutch system, which may damage components.

Safe Operation - Driving Safely

Responsibilities of the Operator

As the operator of this vehicle, your common sense, judgment, and abilities are the only factors that will prevent injury to yourself, to others around you, and/or damage to the vehicle or environment.

Recreational, Group, and Distance Riding

One of the benefits of this vehicle is that it can take you off-road away from most communities. Stay away from areas designated for other types of off-road use unless it is specifically allowed. This includes snowmobile trails, equestrian trails, cross-country ski trails, mountain bike trails, etc. Join a local UTV or SSV club. A club can provide you with a map and advice, or inform you about areas where you can ride.

Always keep a safe distance from other riders ahead of you and behind you when riding in a group. Never operate carelessly or make unexpected maneuvers with other vehicles close by. Stay on designated trails and riding areas, and discourage others from operating in unauthorized locations.

Avoiding Accidents, Rollovers and Tip-overs

Side-by-side vehicles handle differently from other vehicles. Side-by-side vehicles are designed to handle off-road terrain (for example, the wheel base and track width, ground clearance, suspension, drive train, tires, etc.) and as a result, can overturn in situations where vehicles designed for use primarily on paved or smooth terrain may not.

A rollover or other accident can occur quickly during abrupt maneuvers such as:

- Sharp turns or hard acceleration.
- Deceleration when turning.
- When driving on hills or over obstacles.

Safe Operation - Driving Safely

Abrupt maneuvers or aggressive driving can cause rollovers or loss of control even in flat open areas. If the vehicle rolls over, any part of your body (such as arms, legs, or head) outside of the cockpit can be crushed and trapped by the cage or other parts of the vehicle. You can also be injured by impact with the ground, cab, or other objects.

To reduce the risk of rollovers:

- Use care when turning.
- Adjust steering inputs accordingly to your speed and environment.
- Slow down before entering a turn.
- Avoid hard braking during a turn.
- Avoid sudden or hard acceleration when turning, even from a stop or low speed.
- Never attempt donuts, skids, slides, fishtails, jumps, or other stunts.
- If vehicle starts to skid or slide, steer in the direction of the skid or slide.
- Never slam the brakes and lock the wheels.
- This vehicle is built primarily for OFF-ROAD purposes. Riding on paved surfaces may seriously affect vehicle handling and control. If you must drive on paved surfaces for a short distance, reduce speed and avoid abrupt inputs to steering wheel, accelerator and brake pedals.

This vehicle can roll over sideways, or tip over forward or backwards on slopes or uneven terrain:

- Avoid side hilling (driving along the slope rather than up or down a hill). When possible, drive straight up and down inclines rather than across them. If you must side hill, use extreme caution and avoid slippery surfaces, objects, or depressions. If you feel the vehicle start to rollover or slide sideways, steer downhill if possible.
- Avoid steep hills and follow procedures in this manual for climbing and descending hills.

Safe Operation - Driving Safely

- Sudden changes in terrain such as holes, depressions, banks, softer or harder ground or other irregularities may cause the vehicle to tip or become unstable. Observe the terrain ahead and slow down in areas of uneven terrain.

This vehicle will handle differently when carrying or pulling a load:

- Reduce speed and follow instructions in this manual for carrying cargo or pulling a trailer.
- Avoid hills and rough terrain.
- Allow more distance to stop.

Be prepared in case of rollover:

- Latch side doors or side nets and fasten seat belts to help you avoid sticking out arms or legs.
- Never grab the cage while riding. Hands can be crushed between the cage and the ground in a rollover. Keep hands on the steering wheel or handhold.
- Never try to stop a rollover using your arms or legs. If you think that the vehicle may tip or roll, the driver should keep both hands on the steering wheel and both feet firmly planted on the floor. The passenger should keep both hands on the handhold and both feet firmly planted on the floor.

Avoiding Collisions

At higher speeds, there is an increased risk of losing control, particularly in challenging off-road conditions, and the risk of injury in a collision is greater. Never operate at excessive speeds. Always operate at a speed that is proper for the terrain, visibility, and operating conditions, and your experience. This vehicle does not have the same kind of protection for collisions as a car. For example, there are no air bags, the cab is not fully enclosed, and it is not designed for collisions with other vehicles. Therefore, it is particularly important to fasten seat belts, latch side doors or side nets, and wear proper riding gear.

Safe Operation - Driving Safely

Environment

Off-road recreation is a privilege. Maintain your privilege by respecting the environment and the rights of others to enjoy it:

- Chasing wildlife is illegal. Wildlife can die of exhaustion if chased by a motorized vehicle.
- Never purposely damage the terrain unless the operating area is designated for that type of activity.
- Observe the rule... "what you take in, carry out". Do not litter.

Practice Exercises

Before you go out for a ride, it is very important to familiarize yourself with the handling of your vehicle by practicing in a controlled environment. Find a suitable area to practice and perform the following exercises. It should be at least 147 ft × 147 ft. (45 m × 45 m), and free of obstacles like trees and large rocks.

Remember: Avoid higher speeds until you are thoroughly familiar with the operation of your vehicle.

NOTE:

Low gear is the preferred transmission gear selection for all forward motion other than prolonged high speed travel. Do not use high gear for continuous slow speed travel or towing, as this can lead to excessive heating of the clutch system, which may damage components.

Turning Exercise

Turning is one of the most frequent causes of accidents. It is easier for the vehicle to lose traction or rollover if you turn too sharply, or go too fast. Slow down when you approach a turn.

Practice turning:

- First, learn how to perform slight right turns at very low speeds. Release the throttle before turning and slowly reapply the throttle.

Safe Operation - Driving Safely

- Repeat the turning exercise, but this time maintain the throttle at the same level while turning.
- Finally, repeat the turning exercise while accelerating slowly.
- Practice exercises turning to the left.

Note how your vehicle reacts in these different exercises. CFMOTO recommends releasing the throttle before entering a turn to help initiate directional change. You will feel the lateral force increasing with the speed and with your steering input. The lateral force should be maintained as low as possible to make sure it does not cause the vehicle to roll over.

U-turn Exercise

Practice doing U turns:

- Accelerate slowly and while remaining at low speed, gradually turn the steering wheel to the right until you have completed the U-turn.
- Repeat U-turn exercise with different steering inputs and always at a very low speed.
- Repeat U turn exercise to the left.

As mentioned before in this manual, do not ride on paved surfaces. The vehicle behavior will not be the same, increasing the risk of rollover.

Braking Exercise

Practice braking to get familiar with the brake response:

- Practice braking at low speed first, then increase the speed.
- Practice braking in straight line at different speeds and different braking forces.
- Practice emergency braking. Optimal braking is obtained in straight line, with high force applied, without locking the wheels.

Safe Operation - Driving Safely

Remember, braking distance depends on vehicle speed, load and the type of surface. Also, the tires and brakes conditions play a major role.

Reverse Exercise

Practice using the reverse:

- Place 1 cone marker on both sides of the vehicle beside each rear wheel.
- Move the vehicle forward until you can see the cone markers behind you, then stop the vehicle. Acknowledge the distance required to see obstacles behind you.
- Learn how the vehicle handles in reverse and reacts with steering inputs.
- Always perform this reverse exercise at slow speeds.

Emergency Engine Stopping Exercise

Learn how to stop your engine quickly in an emergency situation:

- While running at low speed, simply turn the ignition key to the off position. This is to familiarize you with the vehicle's reaction when the engine is turned off while driving and to develop this reflex.

Safe Operation - Driving Safely

Operating Your Vehicle

Off-Road Operation

The very nature of off-road operation is dangerous. Any terrain which has not been specially prepared to carry vehicles presents an inherent danger where terrain substance, shape, and steepness are unpredictable. The terrain itself presents a continual element of danger, which must be knowingly accepted by anyone venturing over it.

An operator who takes a vehicle off-road should always exercise the utmost care in selecting the safest path and keeping close watch on the terrain ahead. This vehicle should never be operated by anyone who is not completely familiar with the driving instructions applicable to the vehicle, nor should it be operated on steep or treacherous terrain.

General Driving Tips

Care, caution, experience and driving skill are the best precautions against the hazards of vehicle operation. Whenever there is the slightest doubt that the vehicle can safely negotiate an obstacle or a particular piece of terrain, always choose an alternate route. In off-road operation, power and traction, not speed, are important. Never drive faster than visibility and your ability to select a safe route permit. Never operate the vehicle if the controls do not function normally. See your dealer.

Operating in Reverse

When operating in reverse, check that the path behind the vehicle is free of people or obstacles. Pay attention to blind spots. When it is safe to proceed in reverse, go slowly and avoid sharp turns.



Steering inputs in reverse operation increase the risk of rollover.

Safe Operation - Driving Safely

WARNING

When driving downhill in reverse, gravity can increase the vehicle speed above the set limited reverse speed. Failure to use caution when operating in reverse can result in serious injury or death.

NOTE:

This vehicle is equipped with a reverse speed limiter function. In reverse operation, the engine RPM is limited, thus limiting the vehicle reverse speed. Do not operate at wide open throttle. Open the throttle just enough to maintain a desired speed.

Crossing Paved Roads

If you have to cross a paved road, ensure to have complete visibility on both sides for incoming traffic and decide on exit point on other side of road. Drive in a straight line toward that point. Do not make sharp direction changes or abrupt accelerations as it may result in a rollover situation. Do not travel on sidewalks or bicycle trails, as they are designated specifically for those uses.

Riding on Paved Surfaces

Avoid paved surfaces. This vehicle is not designed to operate on paved surfaces and is more likely to roll over. If you must drive on pavement, turn gradually, go slowly, and avoid abrupt acceleration and braking.

Shallow Water Crossing

Water can be a unique hazard. If it is too deep the vehicle may “float” and topple. Check the water depth and current before you attempt to cross any water. Water depth should not exceed the bottom of the floorboard to safely cross the obstacle.

Safe Operation - Driving Safely

Beware of slippery surfaces such as rocks, grass, logs, etc., both in the water and on its banks. A loss of traction may occur. Do not attempt to enter the water at high speed. Water will affect the braking ability of your vehicle. Make sure you dry the brakes by applying them several times while driving slowly after the vehicle leaves the water.

What to Do If Vehicle is Submerged

If the vehicle becomes immersed, it will be necessary to have it transported to your dealer as soon as possible. Do not attempt to re-start the engine, as water may have been ingested into the cylinders, which can cause internal damage.

Riding in Mud, Ice or Snow

When performing a pre-ride inspection, pay special attention to locations on the vehicle where mud, ice and/or snow accumulations may obstruct visibility of the tail lamps, clog ventilation openings, block the radiator and fan, and interfere with the movement of controls. Before starting with your vehicle, check the steering, throttle and brake pedals for interference-free operation.

Whenever this vehicle is driven on a snow or ice covered path, the tire grip is generally reduced, causing the vehicle to react differently to control inputs from the operator.

Riding on Sand

Sand and riding on sand dunes is a unique experience, but there are some basic precautions that should be observed. Wet, deep, or fine sand may create a loss of traction and cause the vehicle to slide, drop off or become “bogged” down. If this occurs, look for a firmer base. Again, the best advice is to slow down and be watchful of the conditions.

When riding on sand dunes, it is advisable to equip the vehicle with an antenna-type safety flag. This will help make your location more visible to others over the next sand dune. Proceed carefully should you see another safety flag ahead.

Safe Operation - Driving Safely

Riding on Gravel, Loose Stones, or Other Slippery Surfaces

Riding on gravel or loose stones is very similar to riding on ice. They affect the steering of vehicle, possibly causing it to slide and tip over especially at high speeds. In addition, braking distance may be affected. Remember that “gunning” the throttle or sliding may cause loose stones to be ejected rearwards which could hit other people.

Crossing Obstacles

Obstacles on the trail should be traversed with caution. This includes rocks, fallen trees, and depressions. You should avoid them whenever possible. Remember that some obstacles are too large or dangerous to cross and should be avoided. As a guideline, never attempt to cross an obstacle higher than the ground clearance of the vehicle. Small rocks or small fallen trees may be safely crossed. Approach obstacles at low speed and to as much a right angle as possible. Adjust speed without losing momentum and do not accelerate abruptly. The passenger must grasp handhold firmly and brace feet on the floor.

Hill Driving Conditions

When driving on hills or slopes, two things are highly important: be prepared for slippery surfaces or terrain variations, obstacles, and brace yourself properly inside vehicle. If you climb or descend a hill that is too slippery or has too loose a surface, you can lose control. If you go over the top of a hill at high speed, you may not have time to prepare for the terrain on the other side. Avoid parking on a slope. Always put the shift lever in PARK and activate the hand brake when stopped or parked, especially on an incline, to avoid rolling. If you must park on a steep incline, block the wheels on the downhill side using rocks or other suitable material.

Safe Operation - Driving Safely

Uphill Driving

Use the low gear (L) for uphill driving. Due to its configuration, this vehicle has very good traction even while climbing, so much so that tip-over is possible before traction is lost. For example, it is common to encounter terrain situations where the top of the hill has eroded to a point that the hill peak rises very sharply. This vehicle is not designed to negotiate such a condition. Take an alternate route.

If you feel that the slope is getting too steep to climb, apply the brakes to immobilize the vehicle. Put the shift lever in reverse (R), and back straight down the hill, barely releasing brakes to remain at low speed. Do not attempt to turn around. Never coast downhill while the vehicle is in neutral. Do not perform hard braking, as it increases the risk of tip-over.

Downhill Driving

This vehicle can climb steeper slopes than it can descend safely. Therefore, it is essential to assure that a safe route exists to descend a slope before you climb it. Decelerating while negotiating a slippery downhill slope could “toboggan” the vehicle, causing it to slide. Maintain steady speed and/or accelerate slightly to regain control. Never slam the brakes and lock the wheels.

Safe Operation - Driving Safely

Hauling and Towing Loads

Your vehicle can help you perform a number of different light tasks ranging from snow removal, to pulling wood, or carrying cargo. This can change the vehicle handling. To prevent possible injury, follow the instructions and warnings in this manual and on the vehicle.

Always respect the load limits of the vehicle. Overloading the vehicle can over-stress the components and cause failure.

Carrying Loads

The load limit of the vehicle including the weight of operator, passenger, cargo, accessories and trailer towing hitch weight:

ZFORCE 950 Sport : 661.4 lb. (300 kg)

ZFORCE 950 Sport-4 : 1047.2 lb. (475 kg)

Following is an example of suitable total vehicle load distribution:

EXAMPLE OF SUITABLE VEHICLE TOTAL LOADS				
Models	Operator and Passenger	Cargo Box Load (Maximum Permissible Vertical Load On The Coupling Point)	Accessories Storage	Total Vehicle Load
ZFORCE 950 Sport	330.7 lb. (150 kg)	330.6 lb. (150 kg) 119 lb. (54kg)	0 lb. (0 kg)	661.4 lb. (300 kg)
ZFORCE 950 Sport-4	661.4 lb. (300 kg)	330.6 lb. (150 kg) 119 lb. (54kg)	55.1 lb. (25kg)	1047.2 lb. (475 kg)

Safe Operation - Driving Safely

WARNING

Driving in level ground with cargo load or towing load higher than 584 lb. (265 kg), use low gear and the vehicle speed should be lower than 19 mph (30 km/h).

Driving in rough or muddy ground with cargo load or towing load higher than 430 lb. (195 kg), use low gear and the vehicle speed should be lower than 19 mph (30 km/h).

Vehicle Settings When Carrying Loads

If the total load approaches 661.4 lb. (300 kg) (ZFORCE 950 Sport) 1047.2 lb. (475 kg) (ZFORCE 950 Sport-4), including weight of operator, passenger, cargo, accessories and trailer Towing Hitch Weight:

- Inflate the tires to maximum pressure.
- Readjust the suspension coil spring pre-load accordingly.
- Operate with the shift lever in L (low gear) when carrying heavy loads in the cargo box and/or pulling a trailer.

Safe Operation - Driving Safely

Load Distribution

Your vehicle has been designed to carry or tow a certain amount of load. Always:

- Read and understand the load distribution warnings listed on the warning labels.
- Never exceed the specified weights.
- Cargo weight should be mounted as low as possible.
- When operating over rough or hilly terrain with loads or towing, reduce speed and cargo to maintain stable driving conditions.

Pulling or Towing

Your vehicle is equipped with a hitch receptacle and winch (if installed) for towing or pulling.

Pulling a Load

- Never pull a load by attaching it to the cage. This can cause the vehicle to tip over. Use only the trailer hitch or winch (if installed) to pull a load.
- When pulling loads with a chain or cable, ensure that there is no slack before starting and maintain tension while pulling.

Safe Operation - Driving Safely

WARNING

Slack can cause a chain or cable to break and snap back, possibly causing injury.

- When pulling a load, respect the maximum hauling capacity.
- If pulling another vehicle, be sure that someone is controlling the pulled vehicle. They must brake and steer to prevent the vehicle from going out of control.
- Reduce your speed when pulling a load and turn gradually to avoid chains, straps, ropes or cables from catching on the rear wheels. Avoid hills and rough terrain. Never attempt steep hills. Allow more distance for braking, especially on inclined surfaces. Be careful not to skid or slide.
- Before pulling loads with (if installed) a winch, refer to the winch section in this owner's manual.

Towing a Load

If a trailer is used behind the vehicle, make sure that its hitch is compatible with the one on the vehicle. Make sure the trailer is horizontal with the vehicle. Use safety chains or cables that keep the trailer secured to the vehicle in the event of a hitch failure.

Improperly loading a trailer may cause loss of control. Respect the recommended maximum hauling capacity and maximum tongue load. Make sure there is at least some weight on the tongue. Follow these guidelines for hauling and towing of cargo:

WARNING

Overloading the vehicle, carrying or towing cargo improperly, can alter the vehicle handling and may cause loss of control or braking instability.

Safe Operation - Driving Safely

- Always use low gear while towing to avoid clutch wear and belt issues.
- Reduce speed when hauling or towing loads.
- Never exceed the stated load capacity for this vehicle.
- All loads must be secured before operation. Unsecured loads may shift and create unstable operating conditions, which could result in loss of control of the vehicle.
- When operating over rough or hilly terrain, reduce speed and cargo to maintain stable driving conditions.
- Use extreme caution when applying brakes with a loaded vehicle. Avoid terrain or situations that may require backing downhill.
- Load weight distribution should be as low as possible. Carrying a high load raises the center of gravity and creates an unstable operating condition. Reduce load weight when the cargo center of gravity is high.
- When handling off-centered loads that cannot be centered, secure the load and operate with extra caution.
- When operating with loads extending beyond the cargo area, stability and maneuverability may be adversely affected, causing the machine to overturn.
- Towing a load while carrying cargo may cause an imbalanced condition that increases the possibility of vehicle overturn. Balance loads proportionally, but do not exceed the stated load capacity.
- Always attach to the tow using the hitch point and hardware specifically made for towing. Never exceed the recommended Towing Hitch Weight.
- Using chains, straps, rope or other materials to tow objects is not recommended, as these items could get caught in the rear wheels, resulting in vehicle damage or personal injury.

Safe Operation - Driving Safely

- While towing, the vehicle should never exceed 10 mph (16 km/h) towing a load on a level surface. Vehicle speed should never exceed 5 mph (8 km/h) when towing loads in rough terrain, while cornering, or while ascending or descending a hill.
- When stopped or parked, block the vehicle and trailer wheels from possible movement.
- Use caution when disconnecting a loaded trailer; it or its load may topple on you or others.

MAXIMUM HAULING CAPACITY			
Type of Attachment	Trailer Load Allowed	Trailer Hitch Weight Allowed	Note
2 in. (51 mm × 51 mm) hitch ball support	1190 lb. (540 kg)	119 lb. (54 kg)	Includes trailer and trailer load

 WARNING
<p>When the trailer load approaches 1190 lb. (540 kg) and the vehicle riding on a flat road, to ensure safety and reduce the vehicle getting damaged. The following measures should be taken:</p> <ul style="list-style-type: none"> ▪ Vehicle unloaded. ▪ Switch to the 4WD. ▪ Reduce the speed to under 9 mph (15 km/h). ▪ Use the low gear to increase traction and stability.

Safe Operation - Driving Safely

Where a designated attachment point is provided on the towbar

CF1000UTR-6

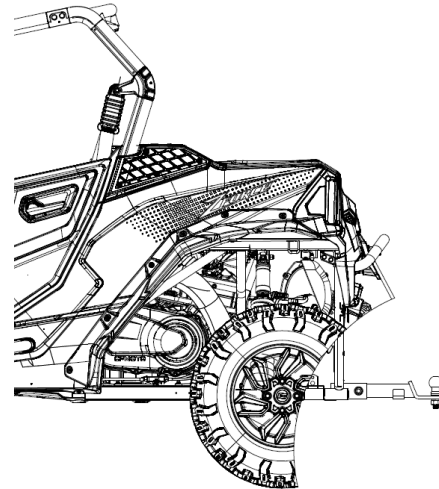
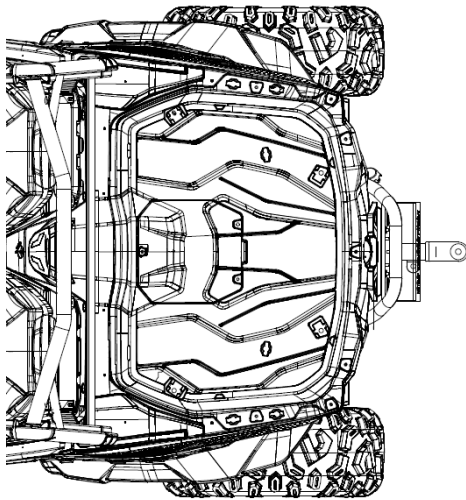

Accessories and Modifications

If no such attachment points are foreseen, the operator s manual shall prohibit the installation of a front-end loader.

This T3 has not attachment points for front-end loader. Do not install front loader.

Safe Operation - Driving Safely

Where a designated attachment point is provided on the towbar

CF1000STR-3L

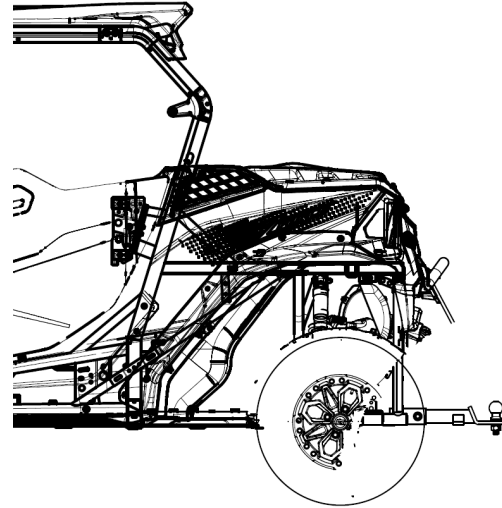
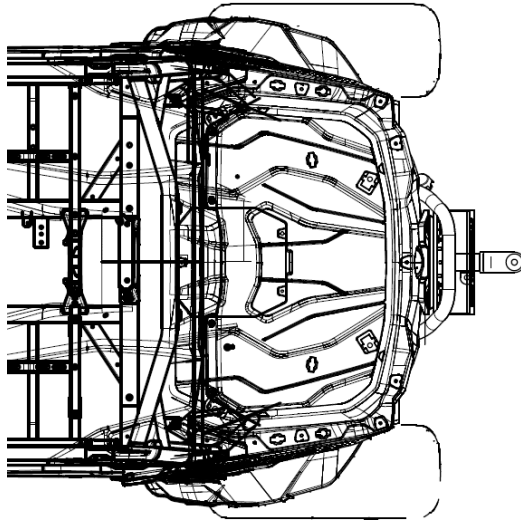

Accessories and Modifications

If no such attachment points are foreseen, the operator s manual shall prohibit the installation of a front-end loader.

This T3 has not attachment points for front-end loader. Do not install front loader.

Safe Operation - Driving Safely

CF1000UTR-6

Place a support under vehicle.

NOTE: Before jacking ensure that all wheels are locked.

NOTE: When the brake lock is applied ensure that the vehicle stays securely in place.

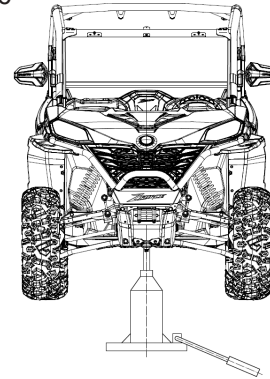

WARNING

DO NOT OVERLOAD your jack beyond its rated capacity. Use jack which is designed for use on hard level surfaces only. Use lifting device only. DO not move or dolly the vehicle while on the jack. Refer to jack warnings and operating instructions prior to use.

Safe Operation - Driving Safely

Place a support under vehicle.

NOTE: Before jacking ensure that all wheels are locked.

NOTE: When the brake lock is applied ensure that the vehicle stays securely in place.

CF1000STR-3L

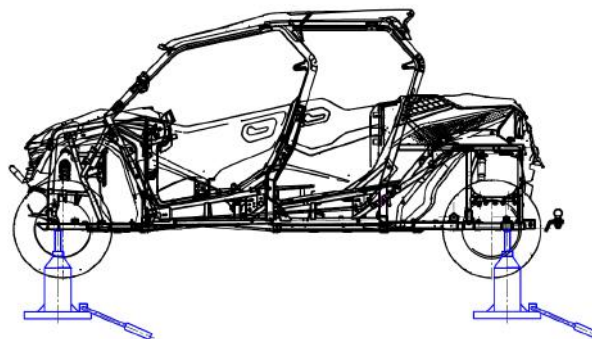
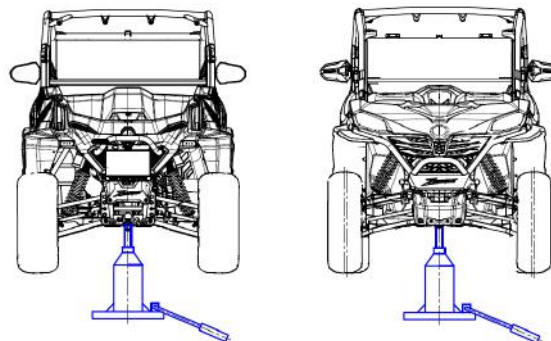

WARNING

DO NOT OVERLOAD your jack beyond its rated capacity. Use jack which is designed for use on hard level surfaces only. Use lifting device only. DO not move or dolly the vehicle while on the jack. Refer to jack warnings and operating instructions prior to use.

Safe Operation - Driving Safely

Intended Use

The tractor is designed solely for use in agricultural or similar operations. Use in any other way is considered as contrary to the intended use. Compliance with and strict adherence to the conditions of operation, service, and repair as specified by the manufacturer, also constitute essential elements of the intended use. The tractor should be operated, serviced, and repaired only by persons who are familiar with its particular characteristics and who are acquainted with the relevant safety procedures. Accident prevention regulations, all other generally recognized regulations on safety and occupational medicine, and all road traffic regulation must be observed at all times. Any arbitrary modifications carried out to this tractor may relieve the manufacturer of liability for any resulting damage or injury. The agricultural tractors can not be used in conditions which may cause the risk of contact with hazardous substances, e.g. spraying of pesticides. In addition, the agricultural tractors also can not used in conditions which may risk of falling and penetrating objects.

Safe Operation - Driving Safely

Winch Operation

(Select Markets) Your vehicle may be equipped with a winch that can pull certain capacities and types of loads. It is useful for vehicle self-recovery when stuck, assisting another vehicle in recovery, moving fallen trees, removing brush, etc.

Consider practicing the operation and use of your winch before you actually need to use it.

The safety warnings, operating precautions and instructions in this section apply if your vehicle came equipped with a winch, or if you choose to install an accessory winch on your vehicle:

Winch Safety Warnings

These safety warnings apply if your vehicle is equipped with a winch, or if you choose to install an accessory winch on your vehicle:

- Read and understand all sections of this manual.
- Improper winch use or failure to correctly follow the winch guidelines, instructions, and warnings in this manual can result in SEVERE INJURY or DEATH.
- Improper or lack of winch maintenance and service could lead to SEVERE INJURY or DEATH.
- Always keep body, hair, clothing, and jewelry clear of the winch cable, fairlead, and hook during winch operation.
- Always keep the area around the vehicle, winch, winch cable and load clear of people, pets, and distractions during winch operation.
- Always wear eye protection and heavy gloves during winch operation.
- Never use alcohol or drugs before or while operating the winch.
- Never allow children under 16 years of age to operate the winch.
- Never attempt to “jerk” a load attached to the winch by moving the vehicle.

Safe Operation - Driving Safely

- Never winch up or down, or to the sides at sharp angles. This can destabilize the winching vehicle and possibly cause it to move without warning.
- Never attempt to winch loads that weigh more than the winch capacity rating.
- Never touch, push, pull, or straddle the cable while winching a load.
- Never let the winch cable run through your hands, even if wearing heavy gloves.
- Never release the drum on the winch when the winch cable is under load.
- Never use the winch for lifting or transporting people.
- Never use the winch to hoist or suspend a vertical load.
- Never retract the hook fully into the winch. This can cause damage to system components.
- Never operate the winch or the vehicle if they are in need of repair or service.
- Always turn the ignition switch OFF and unplug the remote control (if equipped) to prevent inadvertent activation or unauthorized use when the vehicle or winch are not being used.

Winch Operating Precautions

These operating precautions should always be followed if your vehicle is equipped with a winch, or if you choose to install an accessory winch on your vehicle:

- Always inspect your winch and winch cable before each use.
- Always use the provided hook strap when pulling cable out or guiding cable in. Never grab the hook.
- Always align the load directly in front of the vehicle and winch as much as possible. Avoid winching with the cable at a sharp angle to the winching vehicle's centerline whenever possible.

Safe Operation - Driving Safely

- If winching at an angle is unavoidable, follow these precautions while operating:
 - A. Look at the winch drum occasionally. Never let the winch cable “stack” or accumulate at one end of the drum. Too much cable at one end of the drum can damage the winch and cable.
 - B. If cable stacking occurs, stop winching. Follow the ‘Winch Cable Spooling Guidelines’ section in this manual to redistribute the cable evenly before continuing.
- Always apply the vehicle’s park brake and/or park mechanism to hold the vehicle in place during winching. Use wheel chocks when necessary.
- Always maintain at least five full turns of cable wrapped around the winch drum at all times. The friction provided by the wrapped cable allows the drum to pull on the winch cable and move the load.
- Never grease or oil the winch cable. This will cause the winch cable to collect debris that will shorten the life of the cable.
- The winch motor and relay connector may become hot during continuous use. When winching for more than 45 seconds, or if the winch stalls during operation, stop and allow the winch components to cool for a minimum of 10 minutes before using it again.
- Never operate the winch without running the engine. The engine’s charging system helps keep the battery maintained. Battery reserve capacity can be quickly exhausted by heavy winch use, rendering the starting system inoperable.
- Always operate with concern for the environment. Do not purposely damage trees, etc.

Basic Winch Operation

Follow these operating instructions if your vehicle is equipped with a winch, or if you choose to install an accessory winch on your vehicle. Read *Winch Safety Warnings and Winch Operating Precautions* on the preceding pages before using your winch.

Safe Operation - Driving Safely

BEFORE YOU BEGIN - Realize that each winching situation is unique:

- Take your time to think through the winch operation you are about to perform.
 - Proceed slowly and deliberately.
 - Never hurry or rush during winching.
 - Always pay attention to your surroundings.
 - Be prepared to change your winching strategy if it is not working.
 - Remember that although your winch is very powerful, there are simply some situations that you and the winch will not be able to deal with. Do not be afraid to ask others for help when necessary.
1. Always inspect the vehicle, winch, cable and controls for signs of damage or parts in need of repair before each use. Pay particular attention to the first 3 feet (1 meter) of winch cable if the winch is used (or has been used) for lifting a plow. Promptly replace any worn or damaged cable.
 2. Apply the vehicle's park brake and/or park mechanism to hold the vehicle in place during winching. Use wheel chocks when necessary.
 3. Release the winch drum and pull out the required length of cable. Always use the hook strap to handle the hook. Never remove the hook strap from the hook.

CAUTION: Always maintain a minimum of five (5) full turns of cable around the winch drum at all times. The friction provided by wrapping cable allows the drum to pull on the cable and move the load.

4. Attach the hook onto the load, or use a tow strap or chain to secure the load to the winch hook. Never hook the winch cable back onto itself. This can damage the winch cable and result in cable failure.

Safe Operation - Driving Safely

WARNING: Never use a 'recovery strap' for winching. Recovery straps are designed to stretch and could release excessive energy that can result in SEVERE INJURY or DEATH if the strap or winch cable breaks. Use only undamaged tow straps or chains that do not stretch.

5. Re-engage the winch drum.
6. Slowly winch in slack of the winch cable until it is gone, then stop and follow the instructions for 'winch damping' to ensure safe operation:
 - A. Place a damper on the mid-point of winch cable length to absorb energy that could be released by a winch cable failure. A damper can be a heavy jacket, tarp, or other soft, dense object. A damper can absorb much of the energy released if the cable breaks during winching. Even a tree limb can help as a damper if no other items are available to you.
 - B. Lay the damper on top of the mid-point of the winch cable length.
 - C. On a long pull, it may be necessary to stop winching so the damper can be repositioned to a new mid-point. Always release the tension on the winch cable before repositioning the damper.
 - D. Avoid being directly in line with the winch cable whenever possible. Also, never permit others to stand near or in line with the winch cable during winch operation.
7. Stop winching as soon as the job is completed or the load can be moved without the help of the winch.
8. Detach the winch hook, then rewind the cable evenly back onto the drum following the instructions in this manual.

Safe Operation - Driving Safely

GENERAL SAFETY PRECAUTIONS REGARDING THE USE OF WINCH

WARNING

Moving Part Hazards

To prevent serious injury and property damage:

- Do not operate or install winch without reading and understanding these instructions and the Basic Guide to Winching Techniques.
- Keep hands clear of wire rope, hook and fairlead opening during operation and when spooling.
- Use supplied hook strap for spooling wire rope.
- Stand clear of wire rope and load during operation.
- Keep others away.
- Inspect winch installation and wire rope condition before operating winch
- Do not use as a hoist.
- Do not use to move persons.
- Do not exceed winch's rated capacity.
- Never touch wire rope or hook while in tension.
- Be certain the anchor you select will withstand load.
- Never wrap wire rope back onto itself. Use a choker chain or tree trunk protector on the anchor.

- Prior to initiating winching operation be sure any element which can interfere with safe winching is removed.
- Do not disengage clutch if winch is under load or wire rope is in tension.
- Take your time. Sloppy rigging causes accidents.
- The wire rope must always spool onto the drum as indicated by the drum rotation label on the winch.

CAUTION

To avoid injury and property damage:

- Do not use winch to secure a load during transport.
- Do not submerge in water.
- Do not use to tow other vehicles.
- Wear heavy leather gloves when handling the wire rope.
- Never winch with less than 5 wraps of wire rope around the drum.
- Caution should be used if the vehicle is tied down during a winching operation. This may lead to damage to the frame.
- Before winching, inspect remote control lead for damage.

Safe Operation - Driving Safely

Vehicle Recovery Methods

Vehicle Self-Recovery:

- A. Release the winch drum and pull out the required length of cable.
- B. Whenever possible, pick an anchor point that aligns the winch cable to the vehicle's centerline as close as possible. This will help the spooling of the winch cable and reduce the load on the fairlead.
- C. Attach the winch hook to an anchor point. NOTE: If freeing a stuck vehicle by attaching to a tree, use an item such as a tow strap to avoid damaging the tree during winch operation. Sharp cables and chains can damage and even kill trees. Always respect the environment.
- D. Re-engage the winch drum.
- E. Slowly winch in any slack in the winch cable, then damper it.
- F. Shift to the lowest gear available that will propel the vehicle in the direction of winching.
- G. Carefully apply winch power and throttle together to free the vehicle.

CAUTION: Using the vehicle throttle and winching at the same time has risk and is optional. Place the vehicle in neutral and use only the winch if unsure of your operating abilities.

- H. Stop winching as soon as the stuck vehicle is able to propel itself without the help of the winch.
- I. Detach the winch hook, then rewind the cable evenly back onto the drum following the instructions in this manual.

CAUTION: The ONLY time a winch-equipped vehicle should be moving and using the winch is for self-recovery. The winch-equipped vehicle should NEVER use motion to “shock-load” the winch cable in an attempt to recover a second stuck vehicle. See ‘Winch Shock Loading’ section in this manual for more information.

Safe Operation - Driving Safely

Recovery of Another Vehicle:

- A. Release the winch drum and pull out the necessary length of cable.
- B. Attach the winch hook to the vehicle. Whenever possible, pick an anchor point on the stuck vehicle that aligns the winch cable to the winching vehicle's centerline as close as possible. This will help the spooling of the winch cable and reduce the load on the fairlead.

CAUTION: Never attach the winch hook to a suspension component, brush guard, bumper or cargo rack. Vehicle damage may result. Always attach the hook to the strongest available portion of the vehicle frame or hitch.

- C. Re-engage the winch drum.
- D. Slowly winch in any slack in the winch cable, then damper it.
- E. Shift to the lowest gear available on the stuck vehicle that will propel it in the direction of winching.
- F. Carefully apply winch power and the stuck vehicle's throttle together to free it.
- G. Stop winching as soon as the stuck vehicle is able to propel itself without the help of the winch.
- H. Detach the winch hook, then rewind the cable evenly back onto the drum following the instructions in this manual.

Winch Cable Care

Always inspect your winch cable before each use for worn or kinked winch cable. Never use a cable that is damaged. Follow these guidelines for inspection and use:

- A winch cable made of wire rope that is kinked, deformed, or bent is permanently and severely damaged. Promptly discontinue use of a winch cable in this condition.

Safe Operation - Driving Safely

- A kinked winch cable made of wire rope that has been “straightened out”, even though it may look usable, has been permanently and severely damaged. It can no longer achieve its load capacity rating. Promptly discontinue use of a winch cable in this condition.
- A winch cable made of synthetic rope should be inspected for signs of fraying. Replace the cable if fraying is observed. Promptly discontinue use of a winch cable in this condition.
- Replace synthetic winch cable if fused or melted fibers are discovered. The synthetic rope will be stiff and appear smooth or glazed in the damaged section. Promptly discontinue use of a winch cable in this condition.
- Never replace a synthetic winch cable with consumer-grade polymer rope. Only use cable that is specifically designed for winch use.
- Never grease or oil a wire rope winch cable. This will cause the cable to collect debris that will shorten the life of the cable.
- Never operate the winch with a damaged hook or latch. Always replace damaged parts before using the winch.

WARNING: Replace the winch cable and components at the first sign of damage to prevent SEVERE INJURY or DEATH in the event of failure.

Winch Cable Spooling Guidelines

After winching is complete, especially if winching at an angle, it may be necessary to respool the winch cable evenly across the drum. This reduces the chances of the winch cable “wedging” itself between lower layers of cable. You will need an assistant to perform this task:

- A. Release the winch drum.

Safe Operation - Driving Safely

- B. Pull out the winch cable that is wrapped unevenly onto the drum.
- C. Re-engage the winch drum.
- D. Have an assistant pull the winch cable hook strap tightly to apply about 100 lbs. (45 kg) of tension.
- E. Slowly winch the cable in while the assistant moves the end of the cable back and forth horizontally to evenly distribute it onto the drum.

Winch 'Shock Loading'

Your winch (if equipped) is designed and tested to withstand the loads produced when operated from a stationary vehicle. Always remember that the winch, cable and components are NOT designed for shock loading. Follow these guidelines:

- Never attempt to “jerk” a load with the winch. For example, never take up cable slack by moving the winching vehicle in an attempt to move an object. This is a dangerous practice that generates high loads which may exceed the strength of the components. Even a slow moving vehicle can create a large shock load which can cause damage.
- Never quickly turn the winch ON and OFF repeatedly (“jogging”). This is a form of shock loading. This puts extra load on the winch components, the cable, and generates excessive heat in the motor and relay assembly.
- Never tow a vehicle or other object with your winch. Towing with a winch produces shock loading even when towing at slow speeds. Towing from the winch also positions the towing force high on the vehicle, which can cause vehicle instability and the possibility of an accident.

Safe Operation - Driving Safely

- Never use recovery straps with your winch. This is a form of shock loading. Recovery straps are designed to stretch and can store energy. Stored energy in the recovery strap is released if a failure occurs, making the event even more hazardous. Similarly, never use elastic “bungee” cords for winching.
- Never use the winch to tie down the vehicle to a trailer or other transporting unit. This is a form of shock loading that can cause damage to the winch components, the cable, or the transporting unit.

Maintenance

Careful periodic maintenance will help keep your vehicle in the safest, most reliable condition. Inspection, adjustment, and lubrication of important components are explained in the maintenance schedule.

Inspect, clean, lubricate, adjust, and replace parts as necessary. When inspection reveals the need for replacement parts, always use genuine parts available from your dealer.

NOTE:

Periodic service and adjustments are critical. If you are not familiar with performing safe service and adjustment procedures, have a qualified dealer perform the required maintenance for you.

Pay special attention to the engine oil level during cold weather operation. A rise in engine oil level can indicate contaminants collecting in the oil sump or crankcase. Change oil immediately if the oil level begins to rise. Monitor the oil level, and if it continues to rise, discontinue use and determine the cause, or see your dealer.

Severe Use Definition

CFMOTO defines severe vehicle use as:

- Frequent immersion in mud, water or sand
- Racing or race-style high RPM use
- Prolonged low speed, heavy load operation
- Extended engine idle
- Short trip cold weather operation
- Vehicles used in commercial operations

If your vehicle use matches any of these definitions, decrease the service intervals by 50%.

Maintenance

KEY POINTS OF LUBRICATION SCHEDULE:

Check all components at the intervals outlined in the Periodic Maintenance Schedule. Items not listed in the schedule should be lubricated at the general lubrication interval.

- Change lubricants more often under severe use, such as wet or dusty conditions.
- Use All Season Grease on pivot points.
- Lubricate every 500 miles (800 km), before long periods of storage, after pressure washing, or after submerging drive system.

Item	Lubricant	Method
Engine oil	SAE 10W-40 / SAE 5W-40 / SAE 15W-40 SJ or higher (See page 94 for oil viscosity chart)	Screw off, clean, insert and pull out dipstick to check oil level
Transmission oil (1000 Engine)	SAE 75W-90 GL-5	Screw off, clean, insert and pull out dipstick to check oil level
Brake fluid	DOT4	Keep level between upper and lower lines
Front gear case oil	SAE 80W-90 GL-5	Oil capacity: 8.45 oz. (250mL)
Rear gear case oil	SAE 80W-90 GL-5	Oil capacity: 13.53 oz. (400mL)
Suspension pivots and drive train	All Season Grease	Grease gun-Pump grease until it begins to flow from the pivot point

Maintenance

Pre-Ride Maintenance Checklist

Perform these inspections before operating the vehicle:

Item		Maintenance before operation			
		Hour	Calendar	Miles (km)	Remarks
■	Steering system	-	Pre-Ride	-	Visually inspect, test, or check components. Make adjustments and/or schedule repairs when required.
■	Throttle return	-	Pre-Ride	-	
	Front suspension and axles	-	Pre-Ride	-	
	Rear suspension and axles	-	Pre-Ride	-	
	Tires	-	Pre-Ride	-	
	Brake fluid level	-	Pre-Ride	-	
	Brake lever / foot brake function	-	Pre-Ride	-	
	Brake system function	-	Pre-Ride	-	
	Wheels / fasteners	-	Pre-Ride	-	
	Engine oil level	-	Pre-Ride	-	
▶	Air filter / Air box and connections	-	Pre-Ride	-	Visually inspect. Replace filter when dirty.

▶ = Severe Use Item. Inspect frequently on vehicles subjected to severe use.

■ = Have an authorized dealer perform repairs that involve this component or system.

● = Emissions related components. Have an authorized dealer perform repairs that involve this component or system.

Maintenance

Item		Maintenance before operation			
		Hour	Calendar	Miles (km)	Remarks
▶	Air box sediment tube	-	Pre-Ride	-	Inspect. If deposits are visible, clean intake tubes, air box, and replace air filter.
▶	CVT sediment tube	-	Pre-Ride	-	Inspect. If deposits are visible, drain / clean the CVT or have it serviced by a dealer.
■	Headlight aim / General lighting and turn indicators (if equipped)	-	Pre-Ride	-	Inspect. Adjust or replace lights when necessary.
▶	Radiator	-	Pre-Ride	-	Inspect for mud or debris blocking airflow. Clean surfaces when necessary.

▶ = Severe Use Item. Inspect frequently on vehicles subjected to severe use

■ = Have an authorized dealer perform repairs that involve this component or system.

● = Emissions related components. Have an authorized dealer perform repairs that involve this component or system.

Maintenance

Break-In Maintenance Checklist

Perform these maintenance items when the 20-hour vehicle break-in is completed:

Item		Break-in Maintenance (Perform at the interval that arrives first)			
		Hour	Calendar	Miles (km)	Remarks
	General lubrication	20	-	200 (320)	Lubricate all grease points, pivots, cables, etc.
	Engine oil / oil filter / oil strainer	20	-	200 (320)	Change oil and filter. Clean oil strainer.
▶	Engine air filter	20	-	200 (320)	Inspect; replace if dirty; do not clean
■	Engine valve clearance	20	-	200 (320)	Check and adjust as necessary.
	Front / Rear gear case oil	20	-	200 (320)	Check level. Inspect for leaks.
	Coolant	20	-	200 (320)	Check level. Inspect for leaks.
	Transmission oil	20	-	200 (320)	Inspect level.
	Engine hoses, gaskets and seals	20	-	200 (320)	Inspect for leaks.

▶ = Severe Use Item. Reduce interval by 50% on vehicles subjected to severe use.

■ = Have an authorized dealer perform repairs that involve this component or system.

● = Emissions related components. Have an authorized dealer perform repairs that involve this component or system.

Maintenance

Item		Break-in Maintenance (Perform at the interval that arrives first)			
		Hour	Calendar	Miles (km)	Remarks
▶	Brake pads	20	-	200 (320)	Inspect pad thickness.
	Battery	20	-	200 (320)	Check terminals, clean, test battery condition if required.
■	Idle condition	20	-	200 (320)	Inspect for proper rpm. See dealer for service if out of spec or erratic.
■	Steering / Wheel Alignment	20	-	200 (320)	Inspect steering system. See dealer for service if wheel alignment is required.
▶	Foot brake / Hand brake	20	-	200 (320)	Inspect function. Adjust as necessary.
	Gear cases, CV shafts, Propshafts	20	-	200 (320)	Inspect for leaks.

▶ = Severe Use Item. Reduce interval by 50% on vehicles subjected to severe use.

■ = Have an authorized dealer perform repairs that involve this component or system.

● = Emissions related components. Have an authorized dealer perform repairs that involve this component or system.

Maintenance

Periodic Maintenance Schedule

Perform maintenance at the interval that arrives first after the 20-hour break-in period:

Item		Periodic Maintenance Intervals (Perform at the interval that arrives first)			
		Hour	Calendar	Miles (km)	Remarks
▶	Brake pads, Brake disc	100h	Monthly	100 (160)	Inspect brake pad and thickness of the brake disc.
	Battery	100h	-	200 (320)	Check terminals. Clean and test battery condition as necessary.
	Engine hoses, gaskets and seals	100h	-	200 (320)	Inspect for leaks.
▶	Air filter	100h	-	500 (800)	Always inspect pre-ride. Inspect frequently if subjected to severe use. Replace if dirty. Do not clean.
▶	CVT air intake filter screen / filter	100h	-	500 (800)	Clean filter screen or filter, replace with new one if necessary.
▶	General lubrication	100h	3M	500 (800)	Lubricate all grease points, pivots, cables, etc.

▶ = Severe Use Item. Reduce interval by 50% on vehicles subjected to severe use.

■ = Have an authorized dealer perform repairs that involve this component or system.

● = Emissions related components. Have an authorized dealer perform repairs that involve this component or system.

Maintenance

Item		Periodic Maintenance Intervals (Perform at the interval that arrives first)			
		Hour	Calendar	Miles (km)	Remarks
▶	Front gear case oil	100h	12M	1000 (1600)	Inspect level. Change yearly if hours or distance interval is not met.
▶	Rear gear case oil	100h	12M	1000 (1600)	Inspect level. Change yearly if hours or distance interval is not met..
▶	Engine oil / oil filter / oil strainer	100h	12M	1000 (1600)	Inspect for color change. Change if dirty and clean strainer. Change yearly if hours or distance interval is not met.
	Cooling system	100h	6M	500 (800)	Test coolant strength. Pressure test system yearly.

▶ = Severe Use Item. Reduce interval by 50% on vehicles subjected to severe use.

■ = Have an authorized dealer perform repairs that involve this component or system.

● = Emissions related components. Have an authorized dealer perform repairs that involve this component or system.

Maintenance

Item		Periodic Maintenance Intervals (Perform at the interval that arrives first)			
		Hour	Calendar	Miles (km)	Remarks
▶	Radiator	100h	6M	500 (800)	Inspect; clean external surfaces. Clean more frequently if subjected to severe use.
■	Steering system	100h	6M	500 (800)	Inspect. Lubricate.
▶	Front suspension	100h	6M	500 (800)	Lubricate. Check fasteners and A-arm bushings. Replace A-arm bushings if worn or loose.
▶	Rear suspension	100h	6M	500 (800)	Lubricate. Check fasteners and A-arm bushings. Replace A-arm bushings if worn or loose.
▶	Gear shift	100h	1M	500 (800)	Inspect, lubricate, adjust as necessary.
▶ ■	Throttle body / throttle cable	100h	6M	500 (800)	Inspect. Clean carbon deposits. Inspect cable and lubricate frequently if subjected to severe use.

▶ = Severe Use Item. Reduce interval by 50% on vehicles subjected to severe use.

■ = Have an authorized dealer perform repairs that involve this component or system.

● = Emissions related components. Have an authorized dealer perform repairs that involve this component or system.

Maintenance

Item		Periodic Maintenance Intervals (Perform at the interval that arrives first)			
		Hour	Calendar	Miles (km)	Remarks
▶ ■	CVT drive belt	100h	12M	1000 (1600)	Inspect. Replace as necessary. See dealer for service.
■	CVT drive and driven pulleys	100h	12M	1000 (1600)	Clean and Inspect pulleys. Replace worn parts. See dealer for service.
	Fuel filter and hoses	100h	24M	2000 (3200)	Inspect routing and condition. Replace filter and high-pressure hoses every 4 years.
	Cooling hoses	100h	-	1000 (1600)	Inspect routing and condition.
▶	Valve clearance	100h	-	2000 (3200)	Inspect and adjust as necessary. See dealer for service.

▶ = Severe Use Item. Reduce interval by 50% on vehicles subjected to severe use.

■ = Have an authorized dealer perform repairs that involve this component or system.

● = Emissions related components. Have an authorized dealer perform repairs that involve this component or system.

Maintenance

Item		Periodic Maintenance Intervals (Perform at the interval that arrives first)			
		Hour	Calendar	Miles (km)	Remarks
●	Fuel system	100h	12M	500 (800)	Inspect fuel tank, cap, fuel pump and fuel pump relay.
	Spark plug	100h	24M	2000 (3200)	Inspect; Replace if worn or fouled.
■	Engine mounts	100h	12M	1500 (2400)	Inspect condition.
	Exhaust pipe and spark arrestor	100h	12M	500 (800)	Inspect. Clean spark arrestor.
■	Graphite seal ring on the exhaust pipe	100h	24M	2000 (3200)	Inspect; Replace if worn or corroded.
▶	Wiring, fuses, connectors, relays, and cables	100h	12M	1000 (1600)	Inspect wire routing for wear, security. Apply dielectric grease as necessary to connectors subjected to water, mud, etc.

▶ = Severe Use Item. Reduce interval by 50% on vehicles subjected to severe use.

■ = Have an authorized dealer perform repairs that involve this component or system.

● = Emissions related components. Have an authorized dealer perform repairs that involve this component or system.

Maintenance

Item		Periodic Maintenance Intervals (Perform at the interval that arrives first)			
		Hour	Calendar	Miles (km)	Remarks
▶ ■	Wheel bearings	100h	12M	1500 (2400)	Inspect for noise or looseness. Replace as necessary.
▶	Safety Belts	100h	12M	2000 (3200)	Visually inspect belts and test latches. Clean latch mechanism more often if used in severe conditions. Replace as necessary.
▶	Transmission oil	200h	12M	2000 (3200)	Inspect level. Change yearly if hours or distance interval is not met.
	Coolant	200h	24M	4000 (6400)	Change coolant every 2 years if hours or distance interval is not met.

▶ = Severe Use Item. Reduce interval by 50% on vehicles subjected to severe use.

■ = Have an authorized dealer perform repairs that involve this component or system.

● = Emissions related components. Have an authorized dealer perform repairs that involve this component or system.

Maintenance

Item		Periodic Maintenance Intervals (Perform at the interval that arrives first)			
		Hour	Calendar	Miles (km)	Remarks
▶	Brake fluid	200h	24M	1000 (1600)	Inspect fluid for color change. Change fluid every two years.
	Idle condition	-	12M	-	Inspect for proper rpm. See dealer for service if out of spec or erratic.
■	Steering / Wheel Alignment	-	12M	-	Inspect steering system. See dealer for service whenever steering parts or wheel alignment are required.
▶	Foot brake height	-	12M	-	Inspect. Replace brake pads or adjust height as required.

▶ = Severe Use Item. Reduce interval by 50% on vehicles subjected to severe use.

■ = Have an authorized dealer perform repairs that involve this component or system.

● = Emissions related components. Have an authorized dealer perform repairs that involve this component or system.

Maintenance

Inspection and Service Record

INSPECTION AND SERVICE RECORD	SERVICING MUST BE CARRIED OUT ACCORDING TO THE SCHEDULE DEFINED IN THIS OWNER'S MANUAL					
Inspection Number	1	2	3	4	5	6
Date						
Miles / Kilometer						
Dealer Stamp and/or Signature						

Maintenance

INSPECTION AND SERVICE RECORD	SERVICING MUST BE CARRIED OUT ACCORDING TO THE SCHEDULE DEFINED IN THIS OWNER'S MANUAL					
Inspection Number	7	8	9	10	11	12
Date						
Miles / Kilometer						
Dealer Stamp and/or Signature						

Maintenance Maintenance Procedures

Air Filter

Check and change the air filter at the intervals outlined in the Maintenance Schedule. The air filter element should be cleaned or replaced more often if the vehicle is used in extremely dusty or wet areas. Each time air filter maintenance is performed, check the air inlet of the air filter box for obstructions and debris. Check the air filter housing rubber joint to the throttle body and manifold fittings for an airtight seal. Check that all fittings are secure to avoid the possibility of unfiltered air entering the engine.

Air Filter Housing Inspection

Inspect the air filter periodically according to the maintenance schedule. Inspect or clean the air filter more frequently when driving in severe condition.

NOTE:

Do not use high pressure air to clean the air filter, which may destroy the paper fibers and reduce the filter function. If the air filter is dirty and hard to clean, replace it with a new one.

If a large amount of water is present in the air filter, have your dealer check for water entering the engine crankcase.

Maintenance

Air Filter Maintenance

1. Remove passenger seat (For ZFORCE 950 SPORT-4, remove the right passenger seat in a second row.), take off the clasps (1).
2. Pull up and remove the air filter access cover (2).
3. Release the three clasps (3) and remove the air filter cover (4).
4. Remove the filter.
5. Inspect the paper filter element and confirm it could be reinstalled, then brush away accumulated dust gently. Replace with new filter element if necessary.

NOTE
Never attempt to wash the filter.

6. When reinstalling the air filter, inspect the sealing ring for dirt, oil or water deposits, and wipe with clean cloth.
7. Apply a layer of lubricating oil on the diameter of air filter rubber sealing ring, and install it.
8. Install air filter cover (4), verify proper installation and proper sealing.
9. Install air filter access cover (2).

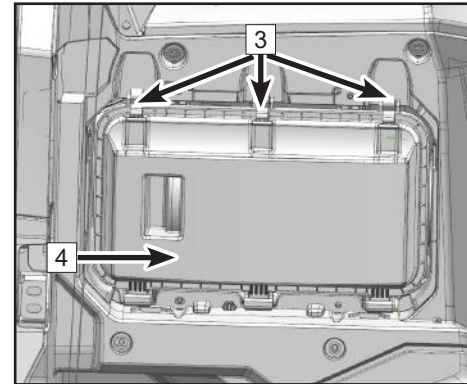
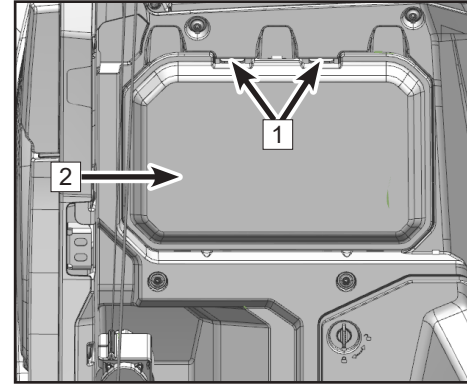

Maintenance

Drying the Air Filter Housing after Submersion

If water has been ingested into the air filter housing, Drain the air filter housing, remove the air filter, and thoroughly dry the components. Do not use compressed air on the paper air filter. Contact your dealer if vehicle performance issues exist.

 **CAUTION**

Do not operate the engine without an air filter element. Unfiltered air entering into the engine can cause engine wear and damage. Driving without an air filter will also decrease performance and can lead to engine overheating.

 **CAUTION**

Major engine damage can result in the vehicle if water has been ingested into the air filter housing, and engine. Have the vehicle serviced by your dealer promptly if your vehicle becomes immersed or stalls in water that exceeds the footrest level. It is important to contact your dealer for service before starting the engine, as water may have been ingested in the air box and engine.

Maintenance

Inspect The Engine Oil Levels

Inspect and replace the engine oil and transmission oil according to the maintenance schedule.

1. Place the vehicle on the level ground and park the vehicle. Start the engine and idle for 30 seconds, then stop the engine. Wait for a few minutes to allow the engine oil to settle down inside the engine.

Transmission Oil Level

2. Remove the passenger seat and front engine service cover (For ZFORCE 950 SPORT-4, two passenger seats in the second row should be removed.) (1).
3. Remove the transmission oil dipstick (2) and clean it.
4. Insert the dipstick back into the dipstick hole, make the dipstick threads contact the hole surface without screwing it in.
5. Remove the oil dipstick and verify the oil level is between the upper and lower mark.
6. Reinstall the oil dipstick and tighten it, and reinstall the front service cover and passenger seat.

Crank Case Oil Level

7. Remove the crank case oil dipstick (3) and clean it.
 8. Insert the dipstick back into the dipstick hole, make the dipstick threads contact the hole surface without screwing it in.
 9. Remove the oil dipstick and verify if the oil level is between the upper and lower mark.
 10. Reinstall the oil dipstick and tighten it.
- Reinstall the engine front access cover and passenger seat.

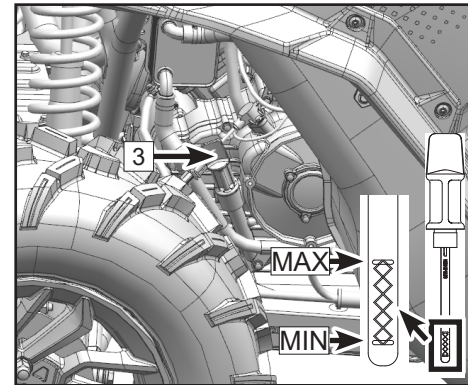
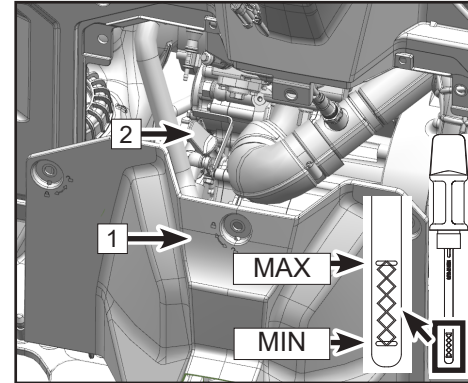

Maintenance

Change the Crankcase Oil

1. Place the vehicle on the level ground and park the vehicle.
2. Start the engine and warm for (2~3) minutes, then stop the engine.
3. Remove the dipstick and wipe it clean.
4. Place a pan under the engine drain hole (1) to store the engine oil.
5. Remove the crankcase magnetic drain bolt and washer to drain out the oil.
6. Confirm the crankcase is drained completely.
7. Remove rear right inner fender panel (2).
8. Remove the three oil filter cover bolts (3) with T-type wrench, then remove the oil filter cover (4).
9. Inspect the O-ring (5), to ensure it is in good condition. Replace with a new one if damaged.
10. Mount O-ring (5) into the oil filter cover and apply a thin coating of fresh engine oil to lubricate it.
11. Install a new oil filter (6).
12. Mount oil filter cover (4), then install and tighten the cover bolts to the specified torque.

Oil Filter Cover Bolt Torque: 7.3 ft·lb.(10N·m)

13. Clean any debris or contaminants from the magnetic drain bolt. Replace the washer with new one if damaged.
14. Install the magnetic drain bolt and washer.

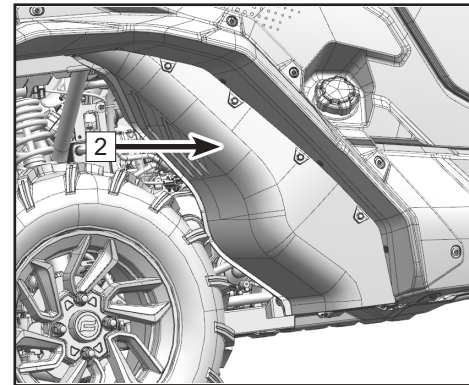
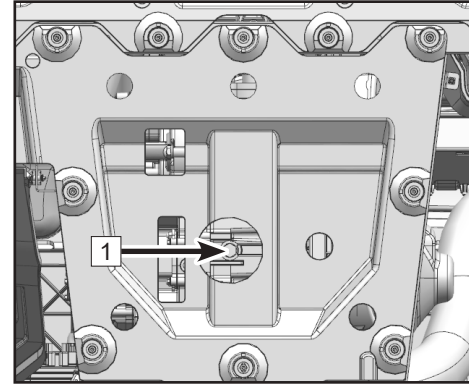

Maintenance

Drain Bolt Torque: 18.5 ft-lb. (25 N·m)

15. Use a dry and clean cloth to wipe the area around magnetic drain bolt.
16. Add the recommended type of oil into oil dipstick hole using the funnel, funnel extension tube and tube adapter supplied with the vehicle. Keep oil level in the specified range.
17. Remove the funnel assy, verify the oil level is between the upper and lower mark with the dipstick, and adjust the oil level accordingly.

CAUTION

Too much or too little oil will have an impact on the normal operation of the engine. Make sure the oil is maintained between the upper and lower marks of the dipstick.

18. Install and tighten the oil dipstick.
19. Verify the vehicle is in parking state, then start and idle the vehicle for 30 seconds.
20. Inspect the engine for leaks after turning off engine. Contact your dealer if leaks are found.

WARNING

Before changing the engine oil, turn off the vehicle, allow it to cool, and keep it in parking position to avoid any injury or death.

21. Dispose the used oil and filter properly.

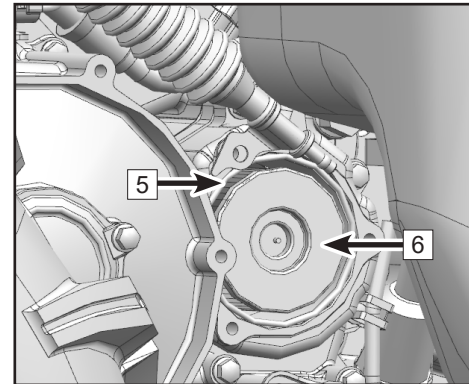
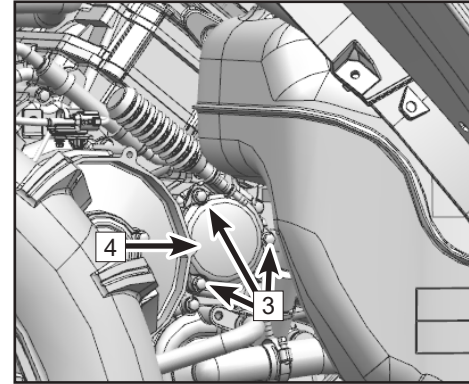

Maintenance

Change Transmission Oil

1. Park the vehicle on the level ground.
2. Start the engine and warm for (2~3) minutes, then stop the engine.
3. Place a pan under the transmission drain hole (1) to store the oil.
4. Remove the dipstick and wipe it clean.
5. Remove the transmission magnetic drain bolt (2) and washer (3) to drain out the oil.
6. Wait until the transmission is drained completely.
7. Clean any debris or contaminants from the magnetic drain bolt (2). Replace the washer (3) with new one if damaged.
8. Install the magnetic drain bolt (2) and washer (3).

Drain Bolt Torque: 14.7 ft-lb. (20 N·m)

9. Use a dry and clean cloth to wipe the area around magnetic drain bolt.

Add the recommended type of oil (SAE 75W-90 GL-5) into oil dipstick hole using the funnel, funnel extension tube and tube adapter supplied with the vehicle. Keep oil level in the specified range.

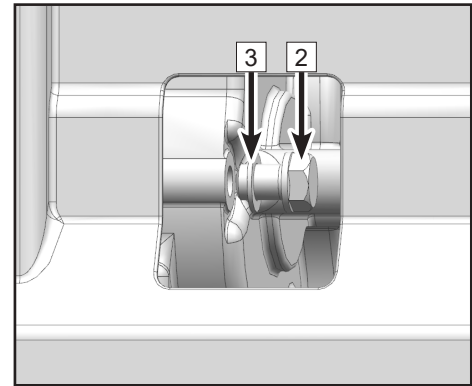
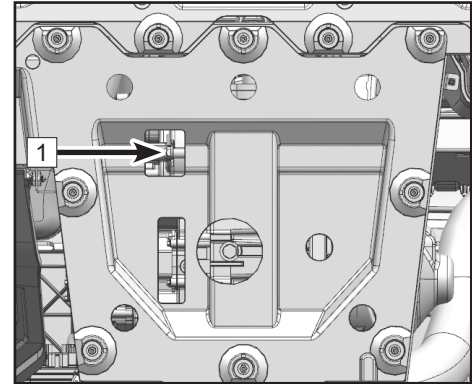

Maintenance

10. Remove the funnel assembly. Verify the oil level is between the upper and lower mark with the dipstick, and adjust the oil level accordingly.

⚠ CAUTION

Too much or too little oil will have an impact on the normal operation of the engine. Make sure the oil is maintained between the upper and lower marks of the dipstick.
--

11. Install and tighten the oil dipstick.
12. Verify the vehicle is in parking state, Then start and idle the vehicle for 30 seconds .
13. Inspect the engine for leaks after turning off engine. Contact your dealer if leaks are found.

⚠ WARNING

Before changing the engine oil, turn off the vehicle, allow it to cool, and keep it in parking position to avoid any injury or death.

14. Dispose the used oil and filter properly.

Maintenance

Engine Valve Clearance Adjustment

The intake and exhaust valve clearances change with use of the vehicle, which can result in improper fuel/air supply or engine noise. To prevent this, the valve clearances must be adjusted according to the maintenance schedule. This adjustment should be performed by a professional service technician. Contact your dealer for service.

NOTE:

Intake valve clearance (cold engine): **0.0024 in ~ 0.0055 in. (0.06mm ~ 0.14mm)**

Exhaust valve clearance (cold engine): **0.0043 in ~ 0.0075 in. (0.11mm ~ 0.19mm)**

Engine Idle Speed

This vehicle is equipped with an electronic fuel injection system. The throttle body is a vital part of the fuel system which requires very sophisticated adjustment, and was set at the factory. There are no consumer provisions to adjust engine idle speed. If the settings are disturbed, poor engine performance and damage may result. Check the engine idle speed for stability or an abnormal engine idle condition and contact your dealer for service if necessary.

Maintenance

Front and Rear Gear Case

Inspect the front and rear gear case for any leaks before operating the vehicle, if found any leaks, stop operating the vehicle and contact with your dealer for inspection and service.

Change the Front and Rear Gear Case Oil

1. Place the vehicle on a level ground, stop the vehicle, turn off the battery and then park the vehicle.
2. Place an oil pan under the gear case to collect the used oil.
3. Remove the magnetic drain bolt and washer at the bottom of gear case.
4. Clean any debris or contaminants from the magnetic drain bolt. Replace the washer with new one if damaged.
5. Wait for several minutes until the gear case is completely drained.
6. Install magnetic drain bolt and washer.

Drain Bolt Torque : 18.4 ft-lb. (25 N·m)

7. Remove filling bolt and washer (3).
8. Add the recommended type of oil (SAE 80W-90 GL-5) by specified volume using the funnel, funnel extension tube and tube adapter supplied with the vehicle.

Front gear case oil volume: 8.45 oz. (250mL)

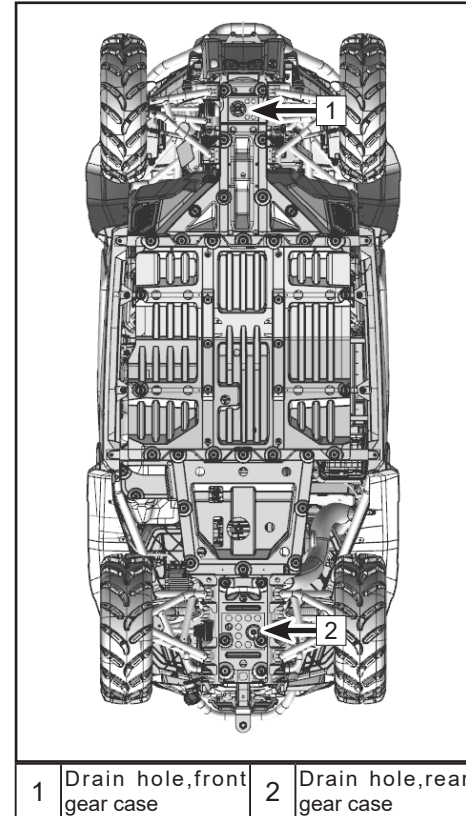

Maintenance

Rear gear case oil volume: 13.5 oz. (400 mL)

9. Mount the filling bolt and washer (3).

Torque for filling bolt: 18.4 ft-lb. (25 N·m)

10. Dispose the used oil in a proper way.

11. The oil replacement method is the same for both front and rear gear cases.

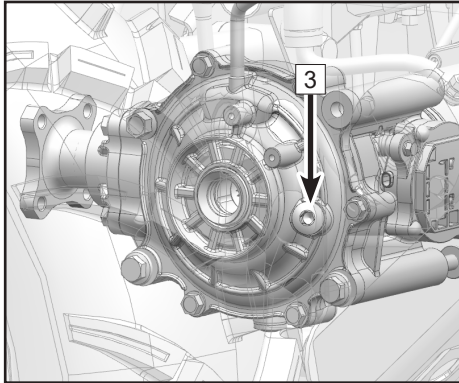

Front Gear Case Oil Filler

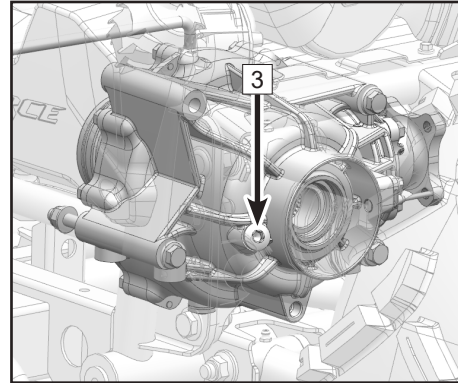

Rear Gear Case Oil Filler

Maintenance

Front and Rear Axle Boots

The front and rear axle boots (1) must be checked for holes or wear before driving. If any damage is found, have your dealer repair the vehicle.

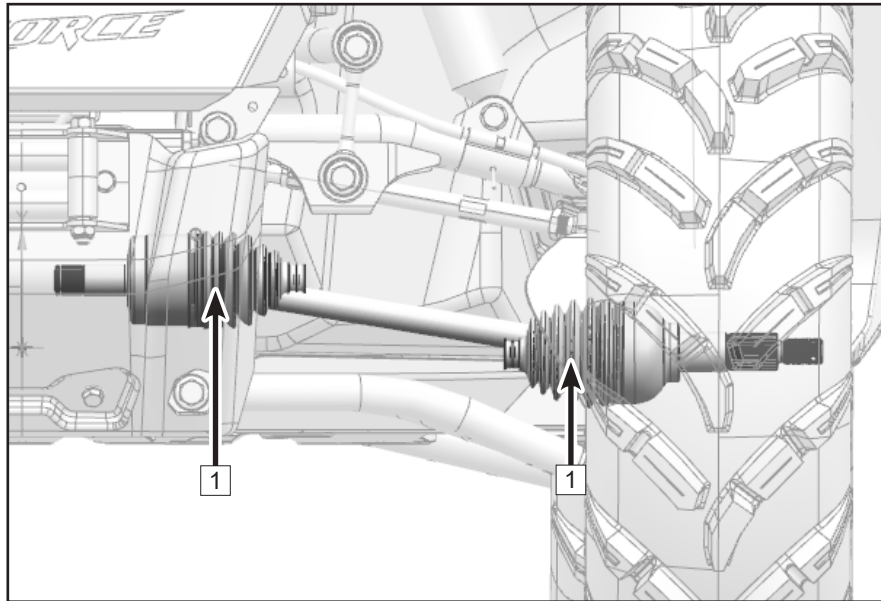

Maintenance

What to do if water collects in the CVT housing

If the vehicle was submerged in water deep enough that water has entered the CVT housing, remove the drain bolt (1) at the bottom of the housing to drain the water from the case.

CAUTION

If water drains from the CVT housing after removing the bolt, have your dealer inspect the vehicle, as water may have affected the CVT system and other engine parts.

Drying a Wet CVT System

If the CVT system was submerged and the drive belt is slipping, any remaining moisture inside the CVT housing after draining can be expelled by running the engine above 2000 RPM in Park or Neutral for (30~60) seconds, then testing for proper CVT function in low gear. Repeat as necessary. If the CVT system continues to slip or have poor performance, contact your dealer.

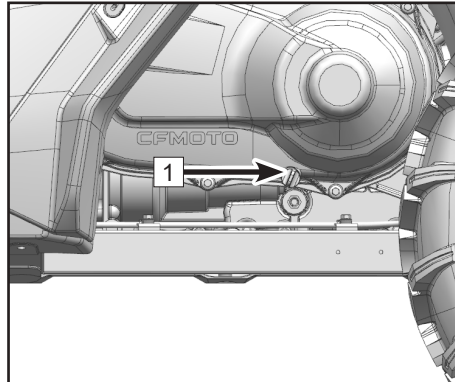

Maintenance

Cooling System

Inspect coolant level

1. Place the vehicle on the level ground, stop the vehicle, turn off the battery, and then park the vehicle.
2. Wait for the engine cooling down to ambient temperature, then inspect the coolant level.
3. Remove the front service cover.
4. Verify coolant level is between upper and lower marks at the side of the coolant reservoir (1).
5. Reinstall the front service cover.

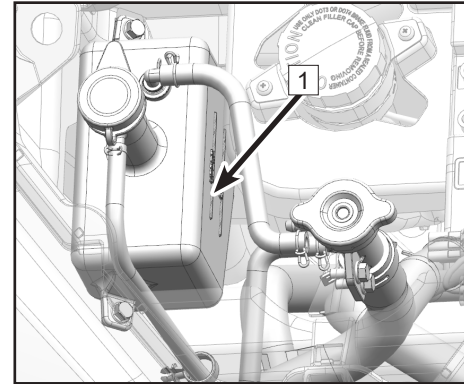

CAUTION

If coolant level is increased, contact your dealer to inspect the antifreeze content of the coolant as soon as possible.

Distilled water can be used for short time if coolant is not available, softened tap water could be the second choice. Never add hard water or salt water, as it is harmful to the engine.

The radiator fan operation is automatically switched on or off according to the coolant temperature in the radiator during operation.

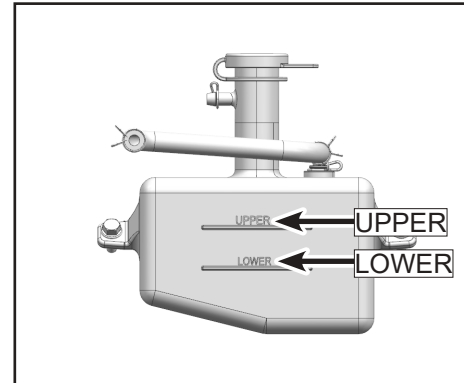

Maintenance

Change the Coolant

WARNING

Never remove the radiator cap if the engine is hot. Wait for the engine to cool down before removing the radiator cap. Hot coolant can cause serious burns.

1. Place the vehicle on a level ground, stop the vehicle, turn off the battery and then park the vehicle.
2. Wait for the engine cooling down to ambient temperature, then inspect the coolant level.
3. Remove the front access cover.
4. Remove radiator cap (1) and coolant reservoir cap (2).
5. Place a container under the front of engine coolant drain bolt (3), then remove the drain bolt and washer.
6. Wait until coolant has drained completely, then install the coolant drain bolt and washer. Replace with new one if washer is damaged. Do not fully tighten the drain bolt at this time.
7. Remove the coolant reservoir hose and allow it to drain completely, then install the coolant reservoir hose.
8. Fill coolant into the radiator using the funnel supplied with the vehicle.

NOTE:

The funnel should be cleaned completely of any oil or other substance that may contaminate the coolant.

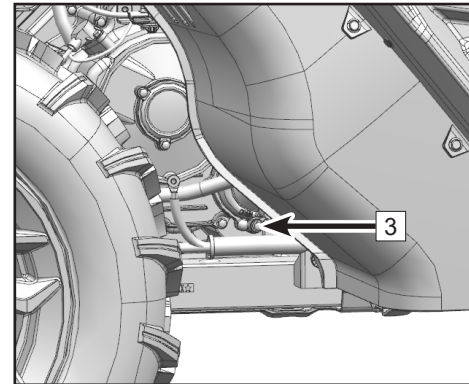
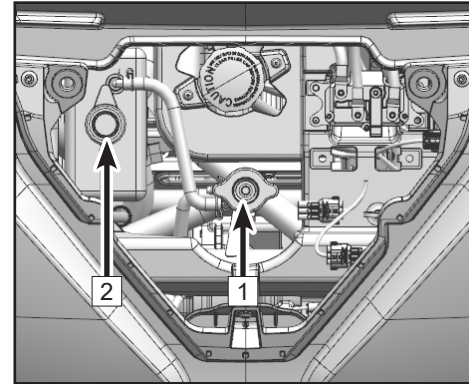

Maintenance

9. During filling coolant, unscrew the coolant drain bolt to release residual air inside the coolant hose until only fluid flows out, then screw back in and tighten the drain bolt.

Drain Bolt Torque: 7.4 ft-lb. (10 N·m)

10. Install radiator cap after full filling the coolant.
11. Start the engine and idle for several minutes until the cooling fan turns on, then turn off the engine.
12. Inspect the coolant level after engine cool-down. Add additional coolant into the top of radiator if coolant level is low.
13. Fill coolant into reservoir until the level is between the upper and lower mark.
14. Install coolant reservoir cap.
15. Start the engine and idle for several minutes to inspect for leaks, contact your dealer to inspect the cooling system if any leaks are found.
16. Install front access cover.
17. Dispose the used coolant in a proper way.

Maintenance

NOTE:

Recommended antifreeze:

Any high quality ethylene glycol antifreeze containing corrosion inhibitors for aluminum engines. CFMOTO recommended coolant freeze protection level: -35°C.

Antifreeze and water mixing ratio: 1: 1

ZFORCE 950 Sport : Coolant capacity (without coolant reservoir): 4.3 qt. (4.1 L)

Coolant change (without coolant reservoir): 4.2 qt. (4 L)

ZFORCE 950 Sport - 4 : Coolant capacity (without coolant reservoir): 5.1 qt. (4.8 L)

Coolant change (without coolant reservoir): 5 qt. (4.7 L)

Coolant reservoir capacity: 0.32 qt. (0.3 L) ~ 0.62 qt. (0.59 L)

(Lower mark: 0.3 L, upper mark: 0.59 L)

Cleaning the Radiator

Cleaning the external surfaces of the radiator if it is covered with mud or debris will ensure it continues to efficiently cool the engine. Use only low pressure water to clean the radiator. High pressure washers can damage components. Ensure that water can flow freely through the radiator fins. This is a sign that cooling air will be allowed to pass through.

WARNING

If replace with different coolant, please contact with your dealer to drain out completely the residual coolant. Different coolant mixture may lead to engine failure.

Maintenance

Spark Plug(s)

The spark plug (1) is an important engine component that is easy to inspect. The color and condition of the spark plug can indicate the condition of the engine. The ideal color on the insulator around the center electrode is a medium-to-light tan color for an engine that is being operated normally. If electrode erosion becomes excessive, or if carbon and other deposits are excessive, you should replace the spark plug with the specified plug.

Periodically remove and inspect the spark plug(s) for heat damage and deposits that will cause them to break down and erode. Do not attempt to diagnose spark plug color or engine problems yourself. Instead, take the vehicle to your dealer for service.

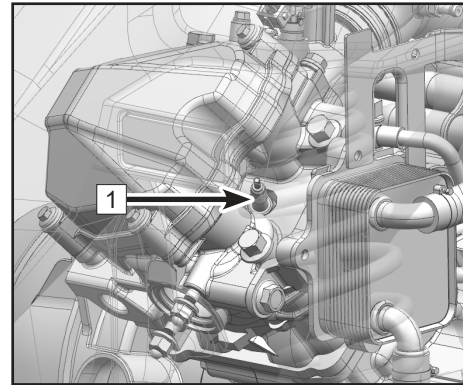
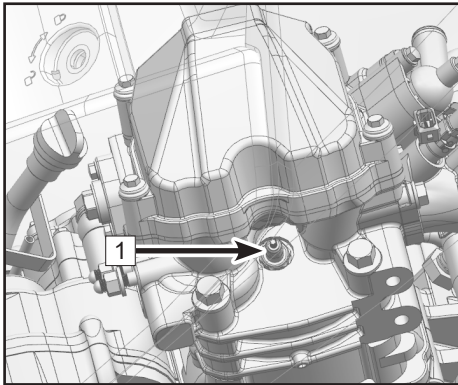

Maintenance

Spark Plug Removal and Inspection

1. Place the vehicle on a level ground, stop the vehicle, turn off the battery and then park the vehicle.
2. Remove the spark plug cap(s).(Please firstly remove the front or rear engine's service cover and then the corresponding front or rear spark plug cap.)
3. Use the spark plug socket and wrench from the tool kit to remove the spark plug.
4. Check the spark plug gap (A) using a thickness gauge. Adjust the gap if necessary.

NOTE:

ZFORCE 950 Sport ZFORCE 950 Sport - 4 Spark plug: CR8EK (NGK)

ZFORCE 950 Sport ZFORCE 950 Sport - 4 Spark plug gap: 0.026 in ~ 0.030 in (0.65 mm ~ 0.75 mm)

5. Clean the gasket surface. Wipe off any grime from the threads.
6. Install spark plug and tighten to specified torque.

ZFORCE 950 Sport ZFORCE 950 Sport - 4 Spark Plug Torque: 11.05 ft-lb. (15N•m).

NOTE: If a torque wrench is not available when you are installing a spark plug, a good estimation of the correct torque is to tighten the spark plug by finger first, then use tool to tighten 1/4 to 1/2 turn.

7. Install the spark plug cap(s).

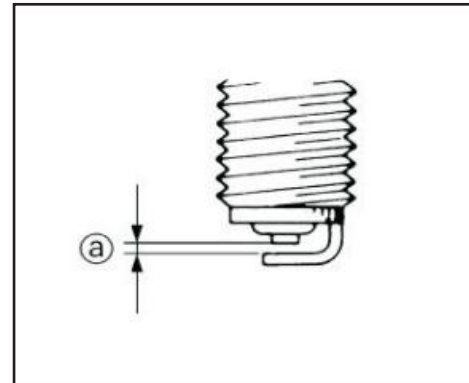
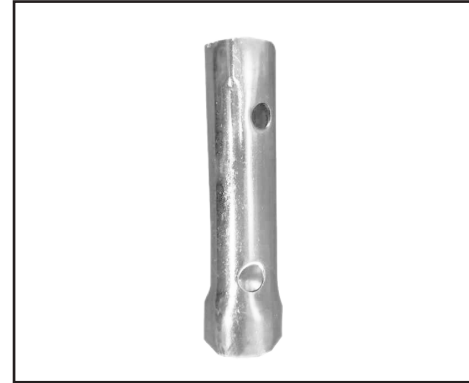

Maintenance

8. Install the access cover(s).

Spark Plug Removal to Expel Water from the Engine

If water has been ingested into the engine, it is important to remove the water as soon as possible by removing the spark plug(s) and using the starter system to rotate the engine for a short period to expel water out of the cylinder(s). Verify that the air box has been drained of water before attempting to expel water. Have a dealer service the engine immediately.

 CAUTION
--

<p>Major engine damage can result in the vehicle if water is ingested into the engine. Have the vehicle serviced by your dealer promptly if your vehicle becomes immersed or stalls in water that exceeds the footrest level. It is important to contact your dealer for service before starting the engine if water has been ingested. Water inside the engine can cause a 'hydraulic lock' effect that can damage the starter and engine components. The engine oil should be checked for water contamination. Drain and refill with new engine oil if water is found in the crankcase.</p>
--

Maintenance

Exhaust Pipe Spark Plug Arrestor

Clean the carbon deposits from the spark arrestor periodically. Blocked spark arrestor will decrease the engine power. After driving through mud or water, inspect the spark arrestor and clean it if necessary.

WARNING

The exhaust system temperature is very high just after operation. Touching the pipe may lead to serious injury. Make sure the exhaust system is cooled, and then proceed with inspection and cleaning.

Remove the cap nuts and washers (1).

Remove spark arrestor (2).

Use a steel brush to clean any carbon deposits from the steel screen (3) of the spark arrestor.

Clean inside the spark arrestor with compressed air.

Inspect for damage or wear to the steel screen of the spark arrestor. Replace with a new spark arrestor if damaged or worn.

Reinstall the spark arrestor, washers and cap nuts onto the muffler. Torque: **7.4 ft-lb. (10 N•m)**.

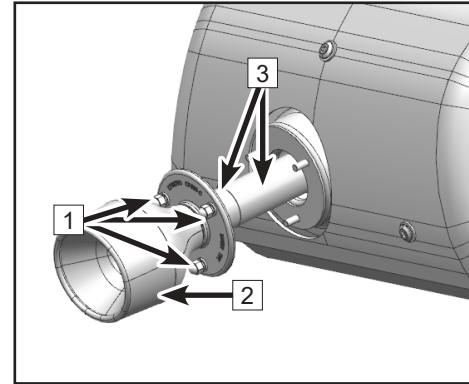

Maintenance

Battery

This vehicle is equipped with a 12 volt / 30 Amp-hour, sealed low maintenance battery (1). The battery is located at the lower position behind the driver seat (For ZFORCE 950 SPORT-4, it is at the lower position behind the left passenger seat in the second row.). It is not necessary to check the electrolyte or add distilled water into the battery. If the battery seems to be discharged, cover is damaged, or other problem exists, contact your dealer.

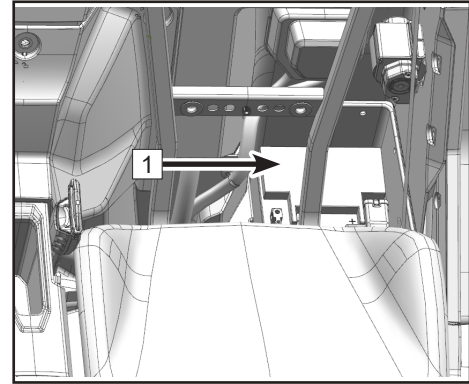

⚠ CAUTION

Do not idle the vehicle engine for more than 20 minutes. If the engine idles for a long time, the battery may discharge to a point that the starter motor will not operate properly. If this should happen, please remove the battery and charge it.

Maintenance

Battery Removal

Park the vehicle on the level ground.

Turn the key to the OFF position to power off the ignition system.

Remove driver seat backrest (For ZFORCE 950 SPORT-4, remove the left seat backrest in the second row.).

Remove front access cover.

Remove the black negative wire (-).

Remove the red positive wire (+).

Remove the battery belt.

Take out the battery.

Battery maintenance

Apply a mixture of baking soda and water with a soft brush to clean the battery top and terminals.

Clean away dirt and any corrosion on positive and negative wire terminals with a stiff brush.

A special battery charger (constant low voltage / ampere) is required for recharging low-maintenance batteries. Using a conventional battery charger may shorten the battery life.

If the vehicle will not be used for a month or longer, take out the battery and store it in a cool, dry place. Completely recharge the battery before re-installation. When charging the battery, it should be taken out from the vehicle.

Maintenance

Battery Installation

Park the vehicle on the level ground.

Turn the key to the OFF position to power off the ignition system.

Place the battery.

Install the battery belt.

Install the red positive wire (+).

Install the black negative wire (-).

WARNING

Avoid contact with skin, eyes or clothing, and always shield eyes when working near batteries. Keep out of reach of children. Keep batteries away from sparks, flames, cigarettes or other sources of ignition. Ventilate the area when charging or using in a closed space.

Battery acid antidote:

EXTERNAL: Flush with water.

INTERNAL: Get prompt medical attention.

EYES: Flush with water for 15 minutes and get prompt medical attention.

NOTE: Wrong operating sequence for installation and disassembly may lead to short circuit between battery and the vehicle.

Maintenance

Battery Charging

Remove battery.

Connect the charger with the positive and negative terminals of battery.

Switch on the charger.

NOTE: It's recommended to charge the battery with current amperage that is 10% of the battery amp-hour capacity.

Disconnect the charger after finishing charging.

NOTE: If the vehicle will not be used for a long time, the battery should be recharged by every three months.

Maintenance

Brakes

Brake Fluid Level Inspection

Before driving, check that the brake fluid level is above the low mark and replenish whenever necessary. The brake fluid reservoir **1** is located under the front service cover. Insufficient brake fluid may let air enter the brake system, possibly causing the brakes to become ineffective.

Observe These Precautions:

- When checking the fluid level, make sure the vehicle is on a level surface.
- Use only the designated quality brake fluid. Otherwise, the rubber seals may deteriorate, causing leaks and poor brake performance.
- Recommended brake fluid: DOT 4.
- Refill with the same type of brake fluid. Mixing fluids may result in a harmful chemical reaction and may lead to poor brake performance.
- Be careful that water does not enter the master cylinder reservoir. Water will significantly lower the boiling point of the fluid and lead to poor brake performance.
- Brake fluid may deteriorate painted surfaces or plastic parts. Always clean up spilled fluid immediately.

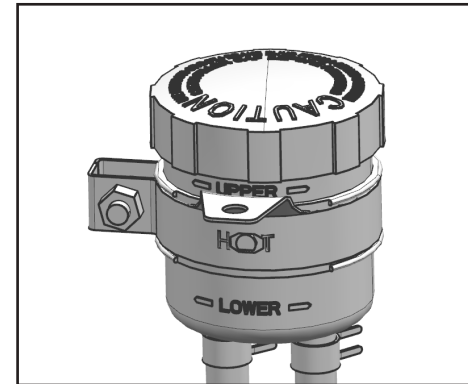
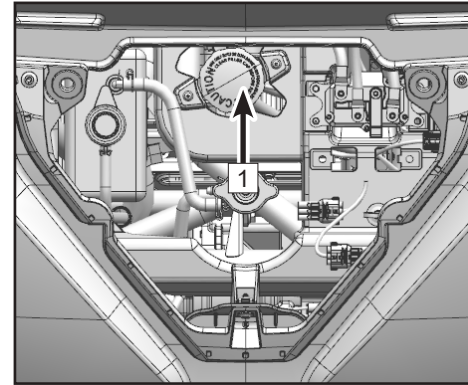

Maintenance

- As the brake pads wear, it is normal for the brake fluid level to gradually go down. A low brake fluid level may indicate worn brake pads or brake system leakage. Therefore, be sure to check the brake pads for wear before checking the brake system for leakage.
- Have your dealer check the cause if the brake fluid level goes down unexpectedly.

Brake Pad Inspection

Inspect the front and rear brake pads and discs for damage and wear. If the pad thickness (A) is less than 008 in. (2.0 mm) or the disc thickness (B) is less than .16 in. (4.0 mm), have your dealer replace them. Replacement of brake components requires professional knowledge, and should be performed by your dealer.

NOTE:

Wheels must be removed to check brake pads.

CAUTION

After servicing:

- Make sure the brakes operate smoothly and that the lever free play is correct.
- Make sure the brakes do not drag and the brake operation is not spongy.
- All air is bled from the brake system.

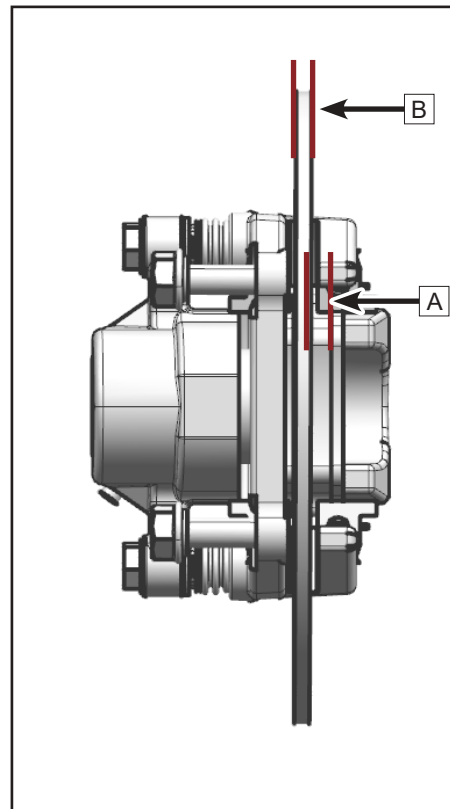

Maintenance

Brake Fluid Change

Complete brake system fluid replacement should be performed only by trained service personnel. Have your dealer replace the following components during periodic maintenance, or when they are damaged or leaking:

- Replace the brake hoses every four (4) years.

 WARNING
--

An over-full master cylinder may cause brake drag or brake lockup, which could result in an accident causing serious injury or death. Maintain brake fluid at the recommended level. Do not overfill.

 WARNING
--

Never store or use a partial bottle of brake fluid. Brake fluid is hygroscopic, meaning it rapidly absorbs moisture from the air. The moisture causes the drop of boiling temperature of the brake fluid, which can lead to early brake fade and the possibility of accident or severe injury. After opening a bottle of brake fluid, always discard any unused portion.
--

Brake Light Operation

The brake light is activated by foot brake pedal pressure, and is properly working when the brake light comes on just as braking takes effect. Check that the switch assembly or the electrical circuit is working properly in case of brake light failure.

Suspension

Some front suspension components of the vehicle do not require maintenance or lubrication. Ensure these components are cleaned regularly, and are not loose or damaged before operating the vehicle.

Maintenance

Suspension Lubricating and Adjustment

Lubricating swing arm bushings and rear stabilizer bar.

Add lubricating grease into grease nipple (1) with a grease gun until it begins to flow from the bushing.

NOTE

The grease nipples on the swing arms and stabilizer bar are symmetrical in left and right. There are a total of 20 grease nipples.

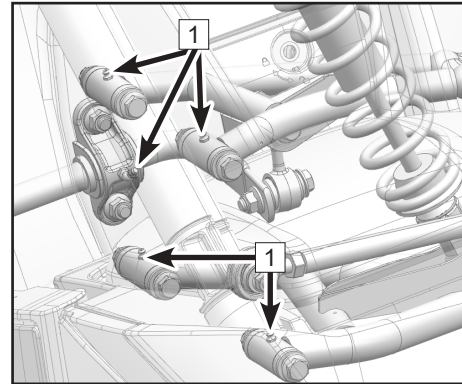
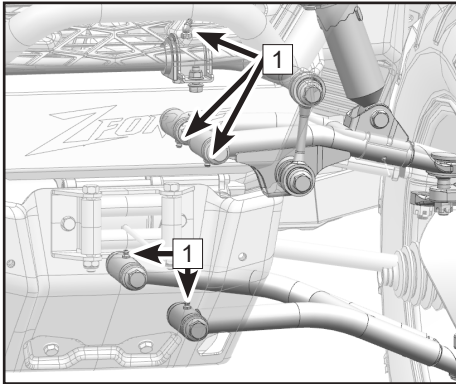

Maintenance

Spring Preload Adjustment - ZFORCE 950 Sport / 950 Sport-4

When riding on rough terrain conditions, using the hitch to tow, or carrying the maximum weight of people and cargo, increase the spring preload to get firmer riding.

Decrease the spring preload as necessary for rough or soft terrain, to get smooth riding.

Proper spring preload setting is a personal preference, and changes with rider weight, riding style and conditions.

Elevating the vehicle with the tires off the ground assists with adjustments. Use a suitable device to measure the spring length, keeping the left and right preload the same.

Increase spring preload: Loosen the lock nut (1). Then turn the adjuster clockwise to shorten the spring length (2).

Re-tighten the lock nut (1).

Decrease spring preload: Loosen the lock nut (1), then turn the adjuster counter-clockwise to increase the spring length (2).

Re-tighten the lock nut (1).

NOTE:

Wrenches are included in the tool kit for adjusting shock absorber spring preload.

Keep the left and right preload the same setting.

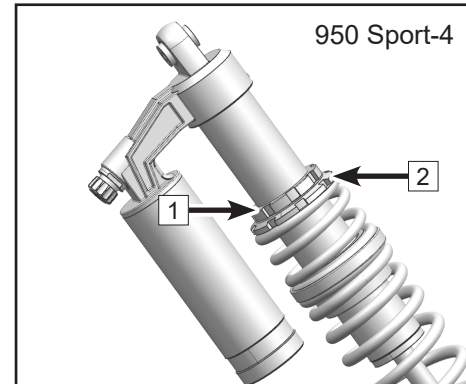
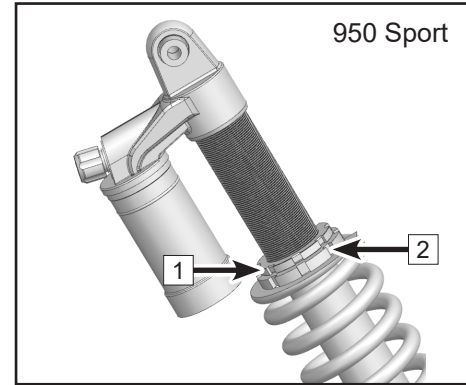

Maintenance

Compression Damping Adjustment

Compression damping (3) controls the suspension compression velocity. The higher the compression damping setting is, the slower the suspension compression velocity is. And the lower the compression damping setting is, the quicker the suspension compression velocity is.

Compression damping adjustment can reduce shaking during turns, and maintains stability to avoid imbalance of the vehicle center of gravity. The shock absorber can absorb impacts and maintain vehicle's stability during a high-speed drive, and the performance is most obvious during continuous bumps.

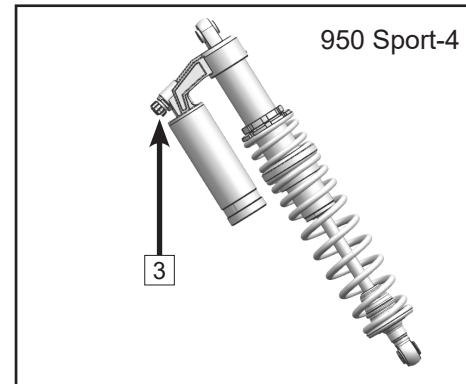
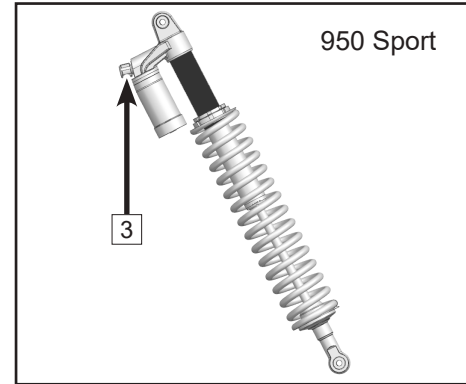

Maintenance

Compression damping adjustment (3):

Compression damping (ZFORCE 950 Sport): Total 3 clicks and the factory setting is the 1st click.

Compression damping (ZFORCE 950 Sport-4): Total 7 clicks and the factory setting is the 4th click.

Turn the adjuster in "HARD" direction, the damping is increasing and please record the click number.

Turn the adjuster in "SOFT" direction, the damping is decreasing and please record the click number.

To restore compression damping to the factory setting:

ZFORCE 950 Sport:

According to the record click number, turn back the same number of clicks to restore factory setting, or turn the adjuster counter-clockwise ("SOFT" direction) to the end, and then turn clockwise ("HARD" direction) to the 1st click for front and rear shock absorbers.

ZFORCE 950 Sport-4:

According to the record click number, turn back the same number of clicks to restore factory setting, or turn the adjuster counter-clockwise ("SOFT" direction) to the end, and then turn clockwise ("HARD" direction) to the 4th click for front and rear shock absorbers.

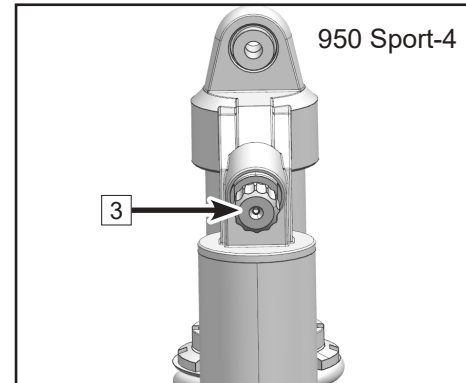
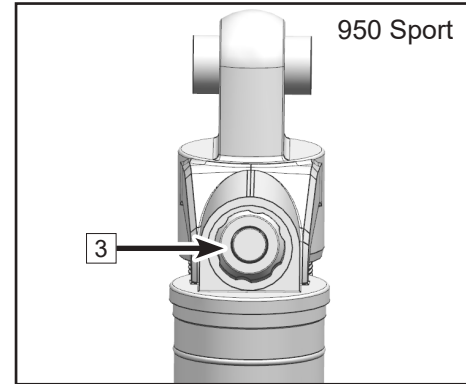

Maintenance

Wheels

Tire Pressure

Before operating the vehicle, use tire pressure pen to inspect the tire pressure:

ZFORCE 950 Sport:

Front tire: 11.6 PSI (80 kPa)

Rear tire: 14.5 PSI (100 kPa)

When fully loaded, front pressure: 14.5 PSI (100 kPa)

When fully loaded, rear pressure: 17.4 PSI (120 kPa)

ZFORCE 950 Sport - 4:

Front tire (2 person): 17.4 PSI (120 kPa)

Rear tire (2 person): 17.4 PSI (120 kPa)

When fully loaded, front pressure(4 person): 21.8 PSI (150 kPa)

When fully loaded, rear pressure(4 person): 21.8 PSI (150 kPa)

Tread Depth

Inspect the tread depth regularly and replace the tires if the minimum tread depth (A) is less than:

Minimum tread depth: **3 / 32 in. (3.0 mm)**

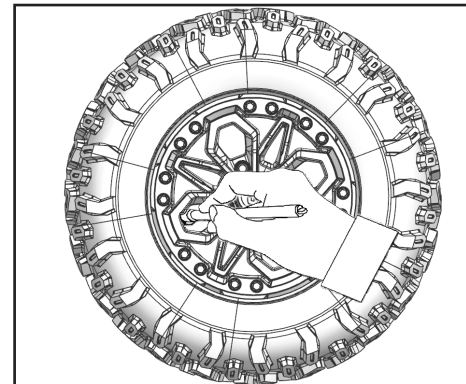
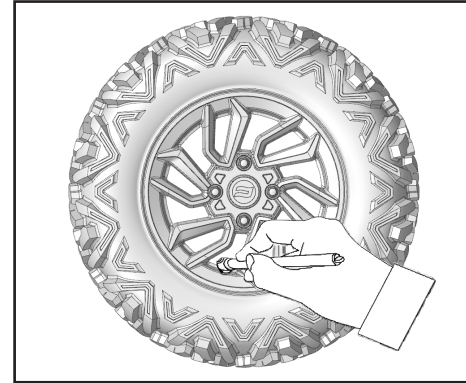

Maintenance

Wheel Bearings

- Lift the vehicle and support it securely under the frame with the tires off the ground.
- Push and pull the wheels at the outer edges to feel for side play or looseness. See your dealer if there is any side play or looseness.

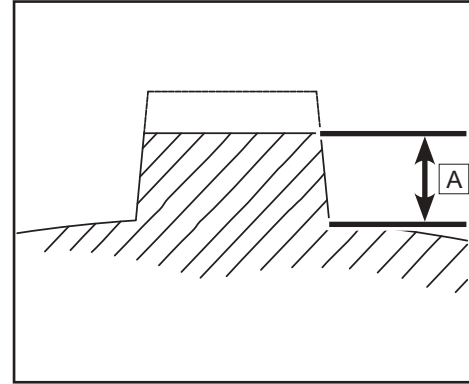

Change the Wheel

Removal

1. Place the vehicle on a level ground.
2. Lift the vehicle and support the vehicle securely under the frame using a jack or other suitable tool so the wheel is off the ground.
3. Remove the wheel nuts (1).
4. Remove the wheels.

Installation

1. Install the wheels onto the wheel hub and secure with wheel nuts.
2. Torque the wheel nuts to specification.

Wheel Nut Torque: 81 ft-lb ~ 88 ft-lb. (110 N·m ~ 120 N·m)

3. Remove the vehicle support and place vehicle on the ground.

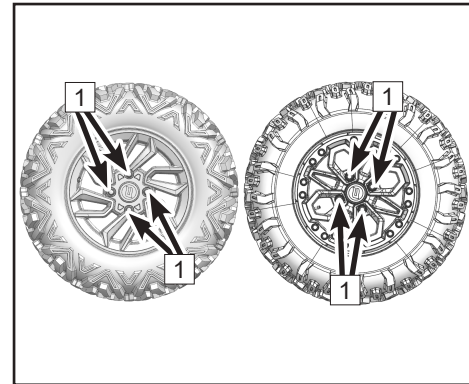

Maintenance

Headlight Adjustment

To adjust the headlight:

Adjust the high beam adjustment screw (1) to adjust the high beam direction vertically.

Adjust the low beam adjustment screw (2) to adjust low beam direction vertically.

WARNING

It is advisable to have your dealer perform headlight adjustments. Improper adjustment could lead to an accident resulting in serious injury or death.

NOTE

Dirt and/or debris can collect underside between the headlights and the front hood, especially after driving in muddy terrain. When washing and cleaning the vehicle, a best practice is to occasionally remove the front hood panel and storage compartment to clean collected debris from the headlight areas with low-pressure water.

LED lamps for the vehicle

All lamps for this vehicle are LED structure which cannot be repaired if damaged or failed, have your dealer replace the entire assembly if an LED is damaged or has failed.

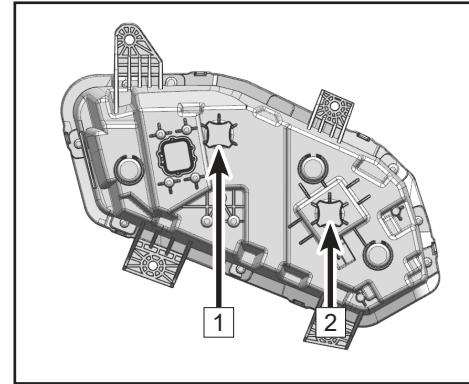

Safety Seat Belt

This vehicle is equipped with 3-point seat belts to help protect the driver and passenger in the event of collisions, rollovers or tip-overs and to help keep occupants in the cab. Make sure the seat belt is firmly fastened before operation.

WARNING

Falling from the moving vehicle could lead to an accident resulting in serious injury or death. Always verify the seat belts are latched securely before operating the vehicle.

Follow the below steps to fasten the seat belt:

- Pull the latch plate **1** down and route the belt over the chest and lap. Make sure there is no distortion or twist in the safety belt.
- Insert latch plate **1** into the buckle **2** until there is click sound.
- Release more seat belt if required and adjust fit as necessary, then let it retract automatically.
- To release the seat belt, press the red button in the center of buckle.

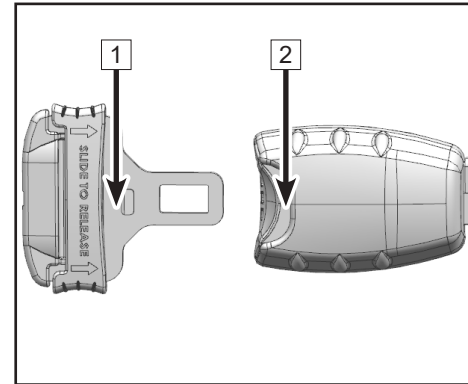

Inspect all the seat belts before every operation:

- Insert latch plate into the buckle and verify there is click sound. The latch plate should move smoothly and the click sound means it is safety locked.
- Press the red button on the buckle to make sure the belt could be released smoothly.
- Pull out all the safety belt and inspect for any damage, including cuts, wear or stiffness. If any damage is found or the belt cannot be used, please contact an authorized CFMOTO dealer for service or replacement.
- Clean the belt with soft soapy water. Do not use bleach, dyes or harsh household detergents. Flush the whole belt, buckle 1 and retractor cover 2 with clean water and allow to air dry.

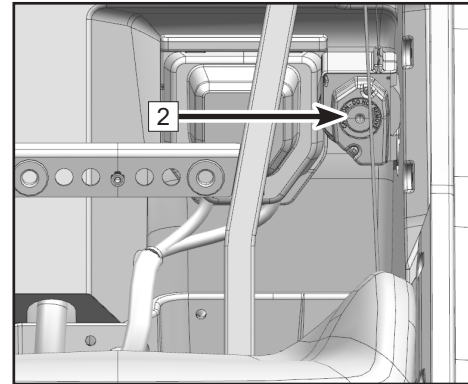
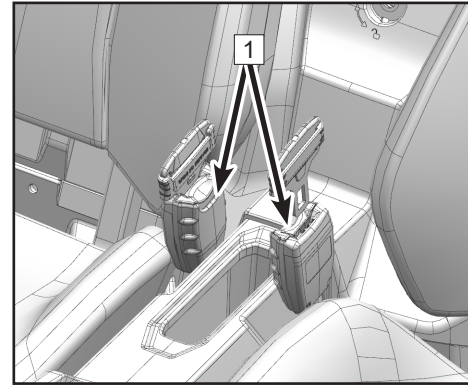

Cleaning and Storage

Washing the Vehicle

Keeping your vehicle clean will not only improve its appearance, but it can also extend the life of various components. With a few precautions, your vehicle can be cleaned much like an automobile:

- The best and safest way to clean your vehicle is with a garden hose and a pail of mild soap and water. Harsh detergents may deteriorate rubber components.
- Use a professional type washing mitten, cleaning the upper body first and the lower parts last.
- Pay special attention that the cooling system radiator and axle boots are thoroughly cleaned of all dirt and debris.
- Rinse with water frequently and dry the vehicle with a chamois to prevent water spots.
- Lubricate all pivot points immediately after washing.
- Allow the engine to run for a while to evaporate any water that may have entered the engine air intake or exhaust system.

CFMOTO does not recommend the use of a high pressure-type car wash system for washing your vehicle, as water can be forced past seals and damage decals. If a high pressure system is used, exercise extreme care to avoid water damage to the decals, wheel bearings, transmission seals, body panels, brakes, warning labels, air filter intake system and electrical system. Ensure water is not allowed to enter into the air filter or CVT housing. If warning and safety labels are damaged, contact your dealer for a replacement.

Waxing the Vehicle

Your vehicle can be waxed with any non-abrasive automotive paste wax. Avoid the use of harsh cleaners since they can scratch the body finish.

Cleaning and Storage



Certain products, including insect repellent and other chemicals, will damage plastic surfaces. Use caution when using these products near plastic surfaces.

Perform Repairs

Make necessary repairs to your vehicle before storing to prevent further damage the next time you operate it.

Check the Tires

Inspect the tire treads and overall condition. Set the tires to the specified air pressure.

Oil and Filter

Warm the engine, then stop the engine and change the oil and filter.

Air Filter/ Air Box

Inspect and clean or replace air filter. Clean the air box and the sediment tube.

Cleaning and Storage

Check Fluid Levels

Inspect the following fluid levels and change if necessary:

- Front gear case
- Rear gear case
- Brake fluid (change every two years or as required if fluid looks dark or contaminated)
- Coolant (change every two years or as required if coolant looks contaminated)
- Fuel Level (add fuel stabilizer according to the product label directions)

Stabilize the Fuel

Fill the fuel tank with fresh fuel that has been treated with fuel stabilizer according to the product label directions. Do not allow untreated fuel to remain in the tank longer than 30 days, as the fuel begins to degrade and can cause damage to the fuel system components.

Battery Storage

- Remove the battery from the vehicle and ensure that it is fully charged before placing it in storage. Protect the battery from freezing temperatures, which can damage the battery.

Lubricate

Inspect all cables and lubricate with cable lubricant according to the product label directions. Grease the vehicle lubricating points with all season grease.

'Fog' the Engine

- Remove the access covers to access the spark plug(s).

Cleaning and Storage

- Remove the spark plug(s), rotate the piston to the bottom of its stroke, and pour approximately 0.6 oz. (15mL ~ 20mL) of engine oil into the opening.

NOTE:

Do this carefully! If you miss the spark plug hole, oil will drain from the spark plug cavity, and appear to be an oil leak. To access the spark plug hole, use a section of clean hose and a small plastic squeeze bottle filled with the pre-measured amount of oil.

- Reinstall the spark plug(s). Torque the spark plug to specification.
- Turn engine over several times slowly. Oil will be forced in and around the piston, piston rings and the cylinder will be coated with a protective film of fresh oil.
- Reinstall the spark plug(s), cap(s), and side panel.

NOTE:

Starting the engine during the storage period will disturb the protective film created by fogging. Corrosion could occur. Never start the engine during the storage period.

Storage Area And Covering

Support the vehicle with stands under the frame with the tires 30 ~ 40mm (1.2 ~ 1.6 in.) off the ground. Be sure the storage area is well ventilated, and cover the machine with an approved cover.

NOTE:

Do not use covers made of plastic or coated materials. They do not allow enough ventilation to prevent condensation, and may promote corrosion and oxidation.

Transporting the Vehicle

Follow these procedures when transporting the vehicle:

- Turn off the engine and remove the key to prevent loss during transporting.
- Ensure the fuel cap is installed correctly and secure.
- Ensure the seats are installed correctly and secure.
- Place the gear selector into any position except the parking position, and block the front and rear wheels to prevent the vehicle from moving.



Never transport with the gear selector in the parking position.

Damage to the engine and transmission may result.

- Secure both the front and rear of the vehicle frame to the transport to prevent the vehicle from sliding or moving.

Vehicle Issue Diagnosis

This section is intended to guide an average owner to simple items that could cause operating problems. Diagnosis of vehicle issues may require the experience of a dealership technician. Please contact your dealer if a solution is not apparent.

Engine Doesn't Turn Over

Possible Cause	Solution
Blown fuse	Reset or replace the fuse
Low battery voltage	Recharge battery to 12.8 Vdc – Confirm battery state of health
Loose battery connections	Check all connections and tighten if necessary
Loose starter system electrical connections	Check all connections and tighten if necessary
Engine stop switch	Check function
Start circuit not complete – transmission in gear	Press foot brake or shift transmission to neutral or parking position.

Engine Pings or Knocks

Possible Cause	Solution
Poor quality or low octane fuel	Replace with minimum E10 or 95(RON) octane unleaded fuel
Incorrect ignition timing.	See your dealer
Incorrect spark plug gap or heat range	Set spark plug gap to specs or replace plugs

Vehicle Issue Diagnosis

Engine Stops or Loses Power

Possible Cause	Solution
Overheated engine	Clean radiator screen and external core. Clean engine exterior. See your dealer
Out of fuel	Refuel with minimum E10 or 95(RON) octane unleaded fuel
Kinked or plugged fuel tank vent line	Inspect and replace. See your dealer
Water present in fuel	Replace with new fuel
Fouled or defective spark plugs	Inspect and clean or replace spark plug
Worn or defective spark plug wires	See your dealer
Incorrect spark plug gap or heat range	Set gap to specs or replace plug
Loose ignition connections	Check all connections and tighten
Low battery voltage	Recharge battery to 12.8 Vdc; check charging system - Confirm battery health
Clogged air filter	Inspect and replace as necessary
Reverse speed limiter malfunction	See your dealer
Electronic throttle control malfunction	See your dealer
Other mechanical failure	See your dealer

Vehicle Issue Diagnosis

Engine Turns Over, Fails to Start

Possible Cause	Solution
Engine turns over, Fails to start	Refuel
Clogged fuel filter	Inspect and replace as necessary
Water is present in fuel	Replace with E10 or 95(RON) minimum octane unleaded fuel
Fuel pump is inoperative	Inspect pump and fuse; Replace as necessary
Old or non-recommended fuel	Replace with E10 or 95(RON) minimum octane unleaded fuel
Possible Cause	Solution
Fouled or defective spark plugs	Inspect spark plugs, replace if necessary
No spark to spark plug	Inspect spark plugs, verify stop switch is on
Crankcase filled with water or fuel	Immediately see your dealer
Clogged air filter	Inspect and replace as necessary; Replace spark plugs as necessary
Clogged fuel injector	See your dealer
Low battery voltage	Recharge battery to 12.8 Vdc. Confirm battery health
Mechanical failure	See your dealer
Worn or defective spark plug wires	See your dealer
Incorrect spark plug gap or heat range	Set gap to specs or replace plugs
Loose electrical connections	Check all connections and tighten
Kinked or plugged fuel tank vent line	Inspect and replace
Incorrect fuel	Replace with E10 or 95(RON) minimum octane unleaded fuel
Reverse speed limiter malfunction	See your dealer
Electronic throttle control malfunction	See your dealer

Vehicle Issue Diagnosis

Engine Backfires

Possible Cause	Solution
Weak spark from spark plugs	Inspect and replace spark plugs as necessary
Incorrect spark plug gap or heat range	Set gap to specs or replace plugs
Old or non-recommended fuel	Replace with minimum E10 or 95(RON) octane unleaded fuel
Incorrectly installed spark plug wires	See your dealer
Incorrect ignition timing	See your dealer
Mechanical failure	See your dealer
Speed limiter malfunction	See your dealer
Other mechanical failure	See your dealer
Possible Lean or Rich fuel mixture	See your dealer
Low or contaminated fuel	Add or change fuel, clean the fuel system
Low octane fuel	Replace with minimum E10 or 95(RON) octane unleaded fuel
Clogged fuel filter	Replace filter
Fuel is very high octane	Replace with minimum E10 or 95(RON) octane unleaded fuel

Vehicle Issue Diagnosis

EFI Malfunction Indicator Light

The Electronic Fuel Injection system on your vehicle contains a self-diagnostic feature that will illuminate the Malfunction Indicator Light (MIL - 1) if it detects a problem. When this indicator is on, a fault code will display on the dashboard directly. Record the fault code and contact your dealer for diagnosing. Your dealer has the EFI tool required to diagnose, repair and clear trouble codes.

During normal operation, the EFI indicator will be off.

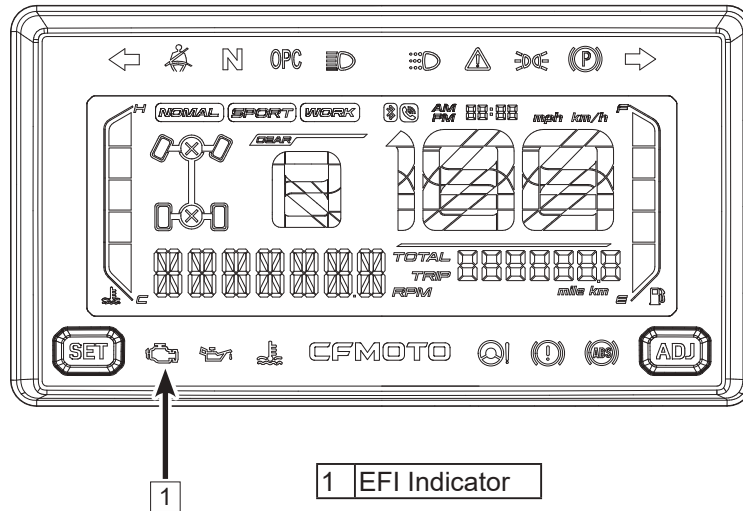

Vehicle Issue Diagnosis

EPS Malfunction Indicator Light

The Electronic Power Steering system on your vehicle contains a self-diagnostic feature that will illuminate the Malfunction Indicator Light (MIL - 1) if it detects a problem. When this indicator flashes, please contact your dealer. During normal operation, the EPS indicator will be on after the ignition switch is turned to ON, but EPS will not work. When the engine is started, the indicator will be off and the EPS starts to function.

A fault code will display on the dashboard directly. Record the fault code and contact your dealer for diagnosing. Your dealer has the special tool required to diagnose, repair and clear trouble codes.

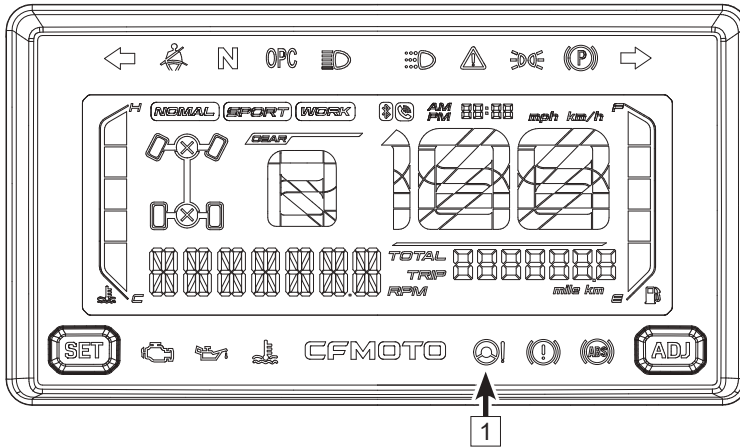

1 | EPS Indicator

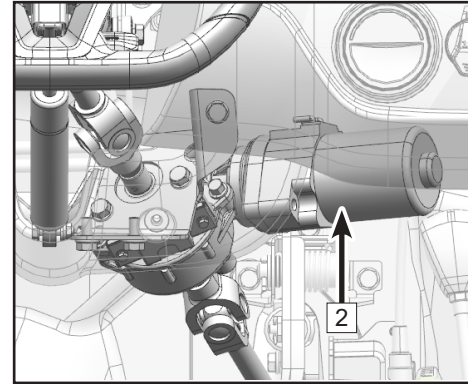

2 | EPS

Vehicle Issue Diagnosis

Electronic Power Steering (EPS) Fault Diagnosis and Solution

Steering without assistance	<ol style="list-style-type: none"> 1. Wire connectors have bad contact or are disconnected 2. The fuse blew out 3. Relay damage 4. The controller, motor, or sensor is damaged 	<ol style="list-style-type: none"> 1. Check whether wire connectors and pins are fully inserted 2. Replace the fuse (40A) 3. Contact your dealer 4. Contact your dealer
Power assist doesn't weigh the same for left and right	<ol style="list-style-type: none"> 1. The median output voltage has deviation 2. Controller, motor or sensor is damaged 	<ol style="list-style-type: none"> 1. Contact your dealer 2. Contact your dealer
When system is 'ON', the steering swings to both sides	<ol style="list-style-type: none"> 1. Motor is mounted backwards 2. Controller or sensor is damaged 	<ol style="list-style-type: none"> 1. Contact your dealer 2. Contact your dealer
Steering becomes heavy	<ol style="list-style-type: none"> 1. Battery has power loss 2. Air pressure of the tires (front) is insufficient 3. Motor damage (power reduction) 	<ol style="list-style-type: none"> 1. Charge the battery 2. Inflate the tires 3. Contact your dealer
System has noise	<ol style="list-style-type: none"> 1. Motor damage 2. Gap of lower steering shaft assembly or mechanical steering assembly is too large 3. Installation of lower steering shaft assembly or mechanical steering assembly is loose 	<ol style="list-style-type: none"> 1. Contact your dealer 2. Contact your dealer 3. Contact your dealer

Vehicle Issue Diagnosis

Declaration

Declaration of Drivers exposure to noise level

The undersigned: Lai Mingjie, General Manager

Company name and address of the manufacturer:

ZHEJIANG CFMOTO POWER CO., LTD.

No.116, Wuzhou Road, Yuhang Economic Development Zone, Hangzhou, 311100

Zhejiang Province P.R.China

Make (trade name of the manufacturer): CFMOTO

Type	Variant(s)	Version(s)	Commercial name(s) (if available)	Category, subcategory and speed index of the vehicle	The Drivers exposure to noise level result (limit: 90dB(A))
CF1000UTR-6	CF1000UTR-6	A	ZFORCE 950 Sport	T1b	85.9 dB(A)
CF1000STR-3L	CF1000STR-3L	A	ZFORCE 950 Sport-4	T1b	84.5 dB(A)

test method 2 of Annex XIII to EU 1322/2014

Vehicle Issue Diagnosis

Declaration of Vibration declaration

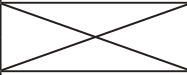
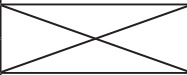
Driver mass	Test run	CF1000UTR-6		a_{ws} / a_{wB}	Requirement
		$a_{ws} \text{ m/s}^2$	$a_{wB} \text{ m/s}^2$		
59±1kg	Test run 1	0.69	1.65		Deviation < 10% between test run 1/2 and Arithmetic mean, $a_{ws} < 1.25 \text{ m/s}^2$
	Test run 2	0.71	1.62		
	Arithmetic mean	0.70	1.64		
98±5kg	Test run 1	0.66	1.53		
	Test run 2	0.62	1.50		
	Arithmetic mean	0.64	1.52		

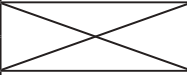
Driver mass	Test run	CF1000STR-3L		a_{ws} / a_{wB}	Requirement
		$a_{ws} \text{ m/s}^2$	$a_{wB} \text{ m/s}^2$		
59±1kg	Test run 1	0.68	0.90		Deviation < 10% between test run 1/2 and Arithmetic mean, $a_{ws} < 1.25 \text{ m/s}^2$
	Test run 2	0.65	0.86		
	Arithmetic mean	0.67	0.88		
98±5kg	Test run 1	0.71	1.05		
	Test run 2	0.73	1.06		
	Arithmetic mean	0.72	1.06		

a_{ws} : rms value of the weighted seat vibration acceleration measured during a standard roadway test

The tests have been carried out in accordance with the requirements of Annex XIV to Regulation(EU) No 1322/2014

Vehicle Issue Diagnosis

CFMOTO LIMITED WARRANTY

ZHEJIANG CFMOTO POWER CO., LTD gives a limited warranty on all components of your CFMOTO Vehicle against defects in material or workmanship within the period and under the conditions described below.

This warranty covers parts and labor charges for repair or replacement of defective parts and begins on the date of purchase by the original retail purchaser. This warranty is transferable to another owner during the warranty period through a CFMOTO dealer, but any such transfer will not extend the original term of the warranty.

LIMITATIONS OF LIABILITY

THIS WARRANTY IS EXPRESSLY GIVEN AND ACCEPTED IN LIEU OF ANY AND ALL OTHER WARRANTIES, EXPRESSED OR IMPLIED, INCLUDING BUT NOT LIMITED TO ANY IMPLIED WARRANTY OF MERCHANTABILITY OR FITNESS FOR A PARTICULAR PURPOSE. TO THE EXTENT THAT THEY CAN NOT BE DISCLAIMED, THE IMPLIED WARRANTIES ARE LIMITED IN DURATION TO THE LIFE OF THE EXPRESS WARRANTIES. INCIDENTAL AND CONSEQUENTIAL DAMAGES ARE EXCLUDED FROM COVERAGE UNDER THIS WARRANTY. SOME STATES/PROVINCES DO NOT ALLOW FOR THE DISCLAIMERS, LIMITATIONS AND EXCLUSIONS IDENTIFIED ABOVE, AS A RESULT, THEY MAY NOT APPLY TO YOU. THIS WARRANTY GIVES YOU SPECIFIC RIGHTS, AND YOU MAY ALSO HAVE OTHER LEGAL RIGHTS WHICH MAY VARY FROM STATE TO STATE, OR PROVINCE TO PROVINCE.

Neither the distributor, CFMOTO dealer nor any other person has been authorized to make any affirmation, representation or warranty regarding the product, and other than those contained in this limited warranty, if made, shall not be enforceable against CFMOTO. CFMOTO reserves the right to modify this warranty at any time, being understood that such modification will not alter the warranty conditions applicable to the products sold while this warranty is in effect.

Vehicle Issue Diagnosis

REGISTRATION

The Dealer must register the vehicle online and provide the completed registration form to ZHEJIANG CFMOTO POWER CO., LTD within ten (10) days of completing the sale of the vehicle. Please note that NO warranty claims will be processed unless the product warranty online registration form is completed and the form is received by ZHEJIANG CFMOTO POWER CO., LTD from the Dealer. Initial dealer preparation and set-up of your vehicle is very important in ensuring trouble-free operation. Purchasing a machine in the crate or without proper dealer set-up will void your warranty coverage.

EXCLUSIONS-ARE NOT WARRANTED

The following are not warranted under any circumstances:

1. Normal wear and tear;
2. Damage caused by abuse, abnormal use, neglect or operation of the product in a manner inconsistent with the recommended operation described in the Owner's Manual;
3. Damage caused by failure to provide proper maintenance and/or storage, as described in the Owner's Manual;
4. Damage resulting from removal of parts, improper repairs, service, maintenance, or use of parts not manufactured or approved by CFMOTO or resulting from repairs done by a person that is not an authorized servicing CFMOTO dealer;
5. Routine maintenance items, tune-ups, adjustments;
6. Damage resulting from accident, submersion, fire, theft, vandalism or any force majeure;
7. Operation with fuels, oils or lubricants which are not suitable for use with the product (see the Owner's Manual);
8. Damages from rust, corrosion or exposure to the elements;
9. Damage resulting from water or snow ingestion;
10. Damage resulting from the racing or any other competitive activity
11. Damage resulting from use of vehicle as a rental vehicle.

Vehicle Issue Diagnosis

12. Damage resulting from the vehicle has been altered or modified in such a way so as to adversely affect its operation, performance or durability, or has been altered or modified to change its intended use;

13. Incidental or consequential damages, or damages of any kind including without limitation towing, storage, telephone, rental, taxi, inconvenience, insurance coverage, loan payments, loss of time, loss of income etc.

WARRANTY COVERAGE PERIOD

This warranty will be in effect from the date of delivery to the first retail consumer. For the applicable period below:

Twelve (12) CONSECUTIVE MONTHS, for private use owners. Any vehicles used for commercial purposes will have their warranty period reduced to six (6) months.

This warranty period is the CFMOTO factory's basic warranty period, and the duration of this warranty may vary by international region based upon local laws, regulations and distributors' policy. Please Note the warranty period you get from dealers may be the same or more than this limited warranty, but not less.

If ZHEJIANG CFMOTO POWER CO., LTD covers a full engine replacement or a complete vehicle replacement under this warranty, the warranty period does not get extended and remains the same as the original purchase date of the vehicle at issue.

LIMITATIONS OF WARRANTIES AND REMEDIES

The CFMOTO limited warranty excludes damages or failures caused by abuse, accident, fire, or any other cause other than a defect in materials or workmanship and provides no coverage for consumable components, general wear items, or any parts exposed to friction surfaces, stresses, environmental conditions and/or contamination for which they were not designed or not intended, including but not limited to the following items:

Vehicle Issue Diagnosis

- Bushings
- Wheels and tires
- Suspension components
- Seat components
- Clutches and components
- Steering components
- Batteries
- Light bulbs/Sealed beam lamps
- Filter
- Lubricants
- Bearings
- Finished and unfinished surface
- Engine components
- Drive belts
- Hydraulic components and fluids
- Circuit breakers/Fuses
- Spark plugs
- Sealants
- Coolants
- Bearings

CONDITIONS TO HAVE WARRANTY COVERAGE

This warranty coverage is available only if each of the following conditions has been fulfilled:

1. The CFMOTO Vehicle must be purchased as new and unused by its first owner from a CFMOTO dealer authorized to distribute CFMOTO Vehicle in the country in which the sale occurred;
2. The CFMOTO specified pre-delivery inspection process must be completed and documented and signed by the purchaser;
3. The CFMOTO Vehicle must have undergone proper registration by an authorized CFMOTO dealer;
4. The CFMOTO Vehicle must be purchased in the country in which the purchaser resides;
5. Routine maintenance outlined in the Owner's manual must be timely performed in order to maintain warranty coverage. CFMOTO reserves the right to make warranty coverage contingent upon proof of proper maintenance. CFMOTO will not honor this limited warranty to any private use owner or commercial use owner if one of the preceding conditions has not been met. Such limitations are necessary in order to allow CFMOTO to preserve both the safety of its products, and also that of its consumers and the general public.

Vehicle Issue Diagnosis

HOW TO OBTAIN WARRANTY SERVICE

The customer must cease using the CFMOTO Vehicle upon the appearance of an anomaly. The customer must notify a servicing CFMOTO dealer within three (3) days of the appearance of a defect, and provide it with reasonable access to the product and reasonable opportunity to repair it. The customer must also present to the authorized CFMOTO dealer, proof of purchase of the product and must sign the repair/work order prior to starting the repair in order to validate the warranty repair. All parts replaced under this limited warranty become the property of CFMOTO.

WHAT CFMOTO DEALER WILL DO

A CFMOTO authorized Dealer must perform warranty coverage repairs at no charge to the customer, even if they are not the dealer that sold the CFMOTO vehicle to the customer and must use CFMOTO OEM parts for all warranty repairs. All vehicles sold by the dealer must be inspected and tested by the dealer to ensure proper performance and operation prior to delivery to the customer. No vehicles may be delivered to a customer without first passing a dealer inspection and an operational test.

EXPORTED PRODUCTS

EXCEPT WHERE SPECIFICALLY REQUIRED BY LAW, THERE IS NO WARRANTY OR SERVICE BULLETIN COVERAGE ON THIS PRODUCT IF IT IS SOLD OUTSIDE THE COUNTRY OF THE SELLING DEALER'S AUTHORIZED LOCATION. This policy does not apply to products that have received authorization for export from CFMOTO. Dealers may not give authorization for export. You should consult an authorized dealer to determine this product's warranty or service coverage if you have any questions. This policy does not apply to products registered to government officials or military personnel on assignment outside the country of the selling dealer's authorized location. This policy does not apply to Safety Bulletins.

Vehicle Issue Diagnosis

Change of Ownership

If you sell your vehicle, any valid remainder of the warranty can be transferred to the new owner. Please record the details of the exchange below and inform an authorized CFMOTO dealer:

Change of Ownership	Original Purchaser	2nd Owner	3rd Owner	4th Owner
Owner Name				
Address				
City				
State / Zip Code				
Telephone				
E-mail				
Date of Purchase				
Odometer Reading				
New Owner Signature				

NOTE:

If a completed Change of Ownership form does not include the required details or is inaccurate, CFMOTO reserves the right to investigate the actual ownership of the product, the service history, and possibly refuse the application for warranty transfer if the requirements have not been fulfilled.

5BYV-380101-6300-12 EU232

ZHEJIANG CFMOTO POWER CO., LTD.
No.116,Wuzhou Road,Yuhang Economic Development Zone,
Hangzhou 311100,Zhejiang Province,China
Tel: 86-571-86258863 Fax: +86-571-89265788
E-mail: service@cfmoto.com.cn <http://global.cfmoto.com>