

AU110 model Maintenance Manual

Instruction

This manual contains detailed operation for AU110 (ATV), maintenance and adjustment process, disassembly and installation notes, inspection and maintenance points, trouble shooting methods and maintenance technical data, also with graphical data.

Please read the manual carefully and follow the instructions strictly among inspection period, that would enhance the reliability of motor and all parts.

Content

Chapter 1 Service Information

Chapter 2 Seat and Rack

Chapter 3 Body and Covering

Chapter 4 Regular Maintenance and adjustment

Chapter 5 Places around engine

Chapter 6 Engine

Appendix Electrical schematic diagram

All contents in this manual are subject to improve and update without notice. Maintenance is subject to actual condition.

ZHEJIANG KAYO MOTOR CO., LTD.

Conversion table

Item	Unit conversion
pressure	1kgf/cm ² =98.0665kPa; 1kPa=1000Pa
	1PSI=0.0689kgf/cm ²
	1mmHg=133.322Pa=0.133322kPa
Torque	1kgf·m=9.80665N·m
volume	1mL=1cm ³ =1cc
	1L=1000cm ³
Moment	1kgf=9.80665N
Length	1in=25.4mm

Danger/warning/attention

Take the below explanations seriously, it's important for maintenance, especially for engine.

Danger: Be on high alert for danger.

Warn: to be alert to moderate danger.

Attention: to be alert to minor danger.

This manual may doesn't contain some potential risks in engine work and maintenance, so besides the above explanations, the service operator should also have basic mechanical knowledge. If the operator is unsure of completing the entire maintenance operation, consult a more experienced senior technician.

1. Service Information

- 1.1 Operation note
- 1.2 VIN Number
- 1.3 Main parameters list
- 1.4 Maintenance parameters list
- 1.5 Torque tightening
- 1.6 Lubricant, sealant
- 1.7 Cable, hose and wiring diagram

1.1 Operation note

Security

1. Wearing work clothes (coveralls), hat and safety boots suitable for the operation. In some conditions dust glasses, dust masks, gloves and other safety protective supplies are needed to protect you from injury.
2. Do not let the engine long running in airtight spots or unventilated places.
3. In case of scald, don't touch the engine when the engine just stops working.
4. Battery solution (dilute sulfuric acid) is a strong corrosive agent; contact with the skin, splash into the eye burns may lead blindness. Once the battery solution is accidentally touched on clothes or skin, rinse immediately with plenty of water. If the battery solution is touched on eyes, please flush immediately with plenty of water and get treatment in time. Storage battery and battery solution should be kept strictly, keep out of reach of children. Battery charging will produce flammable and explosive hydrogen, once there is a source of fire or spark close, there is an explosion risk. Please charge it in well-ventilated places.
5. As gasoline is flammable and explosive, it is strictly prohibited to set off fireworks in the work site. Pay attention to sparks as well as open flames. Besides, the vaporized gasoline may explode, please choose well-ventilated sites.
6. Attention, the rear wheel, clutch or other rotating parts and movable parts may clip hands and clothes during maintenance.
7. Two or more people must constantly greet each other when operating to ensure safety.

Disassembly and installation instructions

1. All the Parts, lubricants and lipids must be Kayo brand parts or Kayo recommends.
2. When disassemble, Please sort out the parts of each system and kept separately to ensure that all parts can be put back.
3. Keep the vehicle clean before inspection.
4. The Gasket, o-ring, piston pin baffle ring, cotter pin and other parts must be replaced after disassembling.
5. Snap ring will be deformed if the opening is too big during disassembly and easy to fall off after reassemble. Please do not use snap ring which was inelastic.
6. After disassembly and inspection, clean the parts and blow the cleaning agent away with compressed air before measurement. Grease the moving surface before assembly.
7. During disassembly, check all the necessary sites and measure relevant data, make sure the reassembly condition as same as previous state.
8. Bolts, nuts, screws and other fasteners shall be pre-tightened and then tightened in accordance with the specified tightening torque on the diagonal in accordance with the principle of from large to small and from inside to outside.

9. Inspect the rubber parts before disassembling and replaced in advance if necessary. In addition, as the rubber pieces are not resistant to gasoline, kerosene and other erosion, do keep them from volatile oil and grease.

10. Smear or inject recommended grease in specific places as service manual request.

11. Use special tools for disassembly and installation.

12. The ball bearing can be rotated in inner ring or outer ring with finger to confirm whether the rotation is flexible and smooth. If the disassembly method is on the ball, the removed bearing shall not be used again. If there are problems as bellow, please replace bearing.

- Bearing axial and radial clearance is oversized.
- The bearings with a sense of stuck when rotate, clean it. If the bearings still feel stuck after cleaning, replace it. If it can't be cleaned, replace it.
- If the bearing is originally compaction fit with vehicle or axle diameter, but it gets unsuitable after disassembly, replace it.

13. The bearings should be lubricated with oil or grease before assembly. Notice the direction of installation when assemble one-side dustproof bearing. When assemble open or double-sided dustproof bearing, make the manufacturer's logo and dimensions outwards.

14. Let the chamfered side towards force direction when install the rectangular ring. Do not use the ring without elasticity. After assembly, rotate the rectangular ring to confirm that it is firmly installed in the slot.

15. It's important to check whether all fastening parts are tightened and whether the work is normal after assembling.

16. Brake fluid, gas and oil can damage the coating surface, plastic parts, rubber parts, etc., do not let it adhere to these parts.

17. Make the side with manufacturer's mark outside when install oil seal.

- Check the oil seal before using.
- Pay attention not to make oil seal lip curly, do not let burr scratch oil seal lip during assembly.
- Grease the oil seal lip before assembly.

18. When installing rubber pipe parts, insert the rubber pipe into the root of the joint. If there is a pipe clamp, install the pipe clamp in the pipe indentation. Replace the rubber pipe which without tightness.

19. Keep the inner of engine, fuel tank and brake hydraulic system away from dust and clay.

20. Clean the gasket material which attached on the bonding surface of engine before installation. The scratches on the contact surface must be removed uniformly with a whetstone.

21. Do not bend the cable excessively. Deformed and damaged cables may cause poor movement or breakage.

22. When assembling the protective cap parts, if there is a groove insert the protective cap into the groove.

Break-in of engine

ZHEJIANG KAYO MOTOR CO., LTD.

There is a lot of relative motion components in engine, such as piston, piston ring, cylinder, mutually meshing gear, etc., it's very important to have a standard break-in at the beginning of using. Break-in can help the moving parts adapt to each other, correction work, form a smooth friction surface which can bear heavy load, by this way the engine will have excellent performance and reliability.

Recommended break-in time is 20 hours, as follows:

0~10 hours: To avoid continuous operation under the condition of 1/2 throttle, the speed should be changed frequently, and it is not recommended to operate for a long time with a fixed throttle position; Cool the engine for 5 to 10 minutes after each hour of operation. Avoid quick acceleration.

10~20 hours: To avoid continuous operation under the condition of 3/4 throttle, the speed can be changed freely except full throttle.

Note:

- During break-in period, do everyday maintaining, and eliminate hidden trouble in time.
- Break-in period ended, make a maintenance for the vehicle, then putted into formal use.

1.2 VIN Number

Model	AU110
VIN number	
Engine number	

See the attached figure for the position of engraving

- ① VIN number
- ② Nameplate
- ③ Engine number

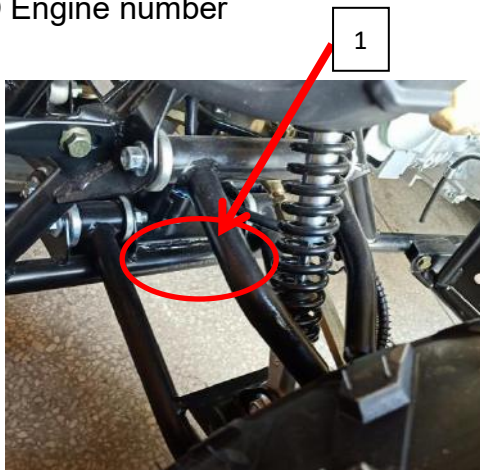



1.3 Main parameters list

No.	Item	
1	Brand	KAYO
2	Type	AU110
3	Name	110cc utility ATV
4	Company	ZHEJIANG KAYO MOTOR CO., LTD.

● Main parameters

1	Dimension (L*W*H) (mm)	1430*860*890
2	Handlebar height (mm)	855
3	Handlebar width (mm)	675
4	Rear height (mm)	740
5	Ground clearance of seat (mm)	665
6	Min. terrain clearance (mm)	115
7	Wheelbase (mm)	910
8	Front track (mm)	840
9	Rear track (mm)	870
10	Turning radius (mm)	1650
11	Turning angle (degree)	38°±2°
12	Net weight (Kg)	98
13	Max. Speed Km/h	40 (limited speed)

● Engine parameters

No.	Item	
1	Starting type	Electric
2	Type	horizontal , Single cylinder, four stroke, air cooling

ZHEJIANG KAYO MOTOR CO., LTD.

3	Distribution way	SOHC/chain drive		
4	Cylinder diameter × mileage (mm)	52.4*49.5		
5	Compression ratio	9.0:1		
6	Lubrication mode	Combination splash and pressure feed		
7	Oil pump type	Rotor		
8	Lubricating oil filter type	All-flow filter, paper filter		
9	Oil trademark	SAE15W-40		
10	Cooling type	Air cooling		
11	Cooling fluid	/		
12	Air filter type	Filter with sponge filter element		
13	Carburetor	Horizontal plunger type (JingkePZ22/EPA state)		
14	Tank volume	2L		
15	Clutch type	Dry automatic clutch		
16	Gearshift method	1+1shiftear with foot、with reverse gear		
17	Gear range	1 forward gear, 1 reverse gear		
18	Shift type	R~N~D		
19	Reduction ratio		Forward gear D	Reverse gear R
		Primary	Gear hub of clutch/primary gear	
		Single-stage	Gear ratio of forward gear	Gear ratio of forward gear
		Overall		
● Frame				
20	Drive sprocket ratio	37/13		
21	Output type	Chain drive, rear wheel drive		
22	Brake type	Front and rear disc		
23	Suspension type	Freestanding double rocker		
24	Frame type	Steel tube and steel plate welded type		

● Lubricating device

Item		Standard	Limitation
Engine oil capacity	Change oil	800mL (No oil filter element replaced)	—
	Change oil	800mL (replace the oil filter element)	—
	Full capacity	800mL	—

ZHEJIANG KAYO MOTOR CO., LTD.

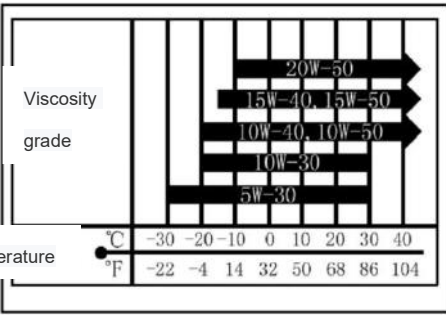
<p>Recommended engine oil (original)</p>  <p>Viscosity grade</p> <p>temperature</p> <p>°C: -30 -20 -10 0 10 20 30 40</p> <p>°F: -22 -4 14 32 50 68 86 104</p>		<p>·four-strokes motorcycles SAE-15W-40</p> <p>For replacements, it must be within following scope:</p> <p>·API classification: SG or upper grade engine oil</p> <p>·SAE specification: refer to left table</p>	
Oil pump rotor	Radial clearance of inner and outer rotors	0.07 mm~0.15mm	0.2mm
	Radial clearance between outer rotor and pump body	0.03 mm~0.10mm	0.12mm
	Axial clearance between rotor surface and pump	0.023 mm ~0.055 mm	0.12 mm
	Oil pressure	1500r/min , 90°C: 200 kPa ~400kPa, General 240 kPa 6000r/min , 90°C:600 kPa ~700kPa, general 600 kPa	

- Air intake system (see engine section)

- Cooling device (without)

- Wheel (front and rear wheels)

Item		Standard	Limitation
Rim jump	Vertical	1.0mm	2.0mm
	Horizontal	1.0mm	1.8mm
Tyre	Residual groove	~	3.0mm
	Air pressure	4.0 PSI	~

- Brake system

Item		Standard	Limitation
Front brake (one with two)	disc thickness	3.5mm	3mm
	Brake handle stroke	5~10mm	~
	Braking force	400N*m	~
Rear brake	disc thickness	3.5mm	~
	Brake handle stroke	10~20mm	~
	Braking force	500 N*m	~

- Ignition device

Item	Standard
Ignition method	CDI electric ignition

ZHEJIANG KAYO MOTOR CO., LTD.

Spark plug	Type	Resistor type spark plug
	Standard	A7RTC/ (torch)
	Gap	0.6~0.7mm
	Spark character	>8mm, one bar
Spark advance angle		
Ignition coil resistance	Primary	0.43~0.57Ω
	Secondary	10.1~11KΩ
Peak voltage	Primary ignition coil	>150V
	Pulse	2V

● Light / Instrument / Switch

Item		Standard
Relay insert fuse		15A
Light	Headlight left and right	LED
	Taillight/brake light	LED
	Gear indicator	LED

● Valve mechanism + cylinder cover (see engine section)

● Cylinder + piston + piston ring + crank connecting link (see engine section)

1.5 Tightening moment of fastener

Note: When installing threads, please manually attach 2~3 turns of thread first.

Tightening moment at specified position-whole vehicle

No.	Item	install position	Bolt specification	Class	Moment N*m
1	Engine	Rear power bolt	M8	10.9	37~50
2		Up power bolt	M8	10.9	37~50
3		Down power bolt	M8	8.8	18~25
4	Suspension	Brake bolts	M10*1.25	8.8	35~45
5		Axle of upper rocker arm	M10*1.25	8.8	35~45
6		Rear rocker arm bolt	M10*1.25	10.9	58~71
7		Fork axle	M12*1.25	8.8	50~60
8	Brake	Rear disc	M8	8.8	18~25 (with blue thread sealants)
9		Front disc	M6	10.9	15~20
10		Disc pump	M8	10.9	29~35
11		Front brake tee	M8	8.8	18~25

ZHEJIANG KAYO MOTOR CO., LTD.

12	Rear axle	Rear axle	M12*1.25	8.8	55~65
13		Nut	M27*1.5		80~90
14		Chain bolt	M6	8.8	8~12
15	Turning	Clamp locking bolt (hexagon)	M8	10.9	18~25
16		Steering column locking	M8	8.8	18~25
17		Bolt of lower raiser	M10*1.5	10.9	50~60
18	Electrical elements	Battery box	M8	8.8	15~20
19		Muffler installation	M8	8.8	15~20
20		Voltage regulator ignition coil	M6	8.8	7~11
21	Oil tank, body parts, plastic	Oil tank	M6	8.8	7~11
22		Oil tank switch	M6	8.8	7~11
23		Plastic screw	TM6		7~11
24		Screw for headlight and plastic	ST4.2		3~5

- **Tightening moment at specified position - engine (see engine section)**
- **Engine service tool (see engine section)**
- **Engine special tool (see engine section)**

1.6 Lubricating grease and sealant

No.	Position	Effect	Grease
1	Dust cap for rocker arms	lubrication	XHP222
2	Ball joint of rocker arms		
3	Steering column bottom		
4	Joints of knuckle and wheel hub		
5	Installation axle for rear fork		
6	Inner sleeves of rear fork		
7	Rear axle liner pipe		
8	Rear axle bearing and oil seal		
9	Steering column clamp		

Note: please coat glue for handlebar grip before installing.

Engine operating materials and installation accessories (see engine section) Engine operating materials includes lubricating oil (engine oil), Grease (butter) and cooling liquid. The installation accessories contains flat coating glue, screw thread sealant etc.

1.7 Wiring diagram of cable, hosepipe and inhaul cable

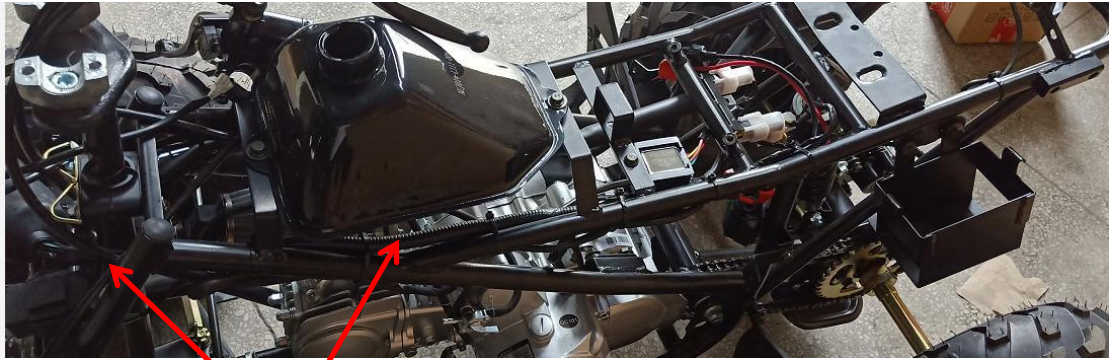

Main cable

Oil tube for front brake

Throttle cable

Oil tube for rear brake

Damper cable

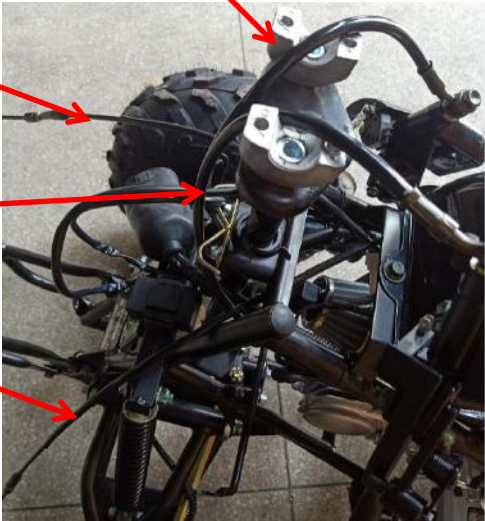

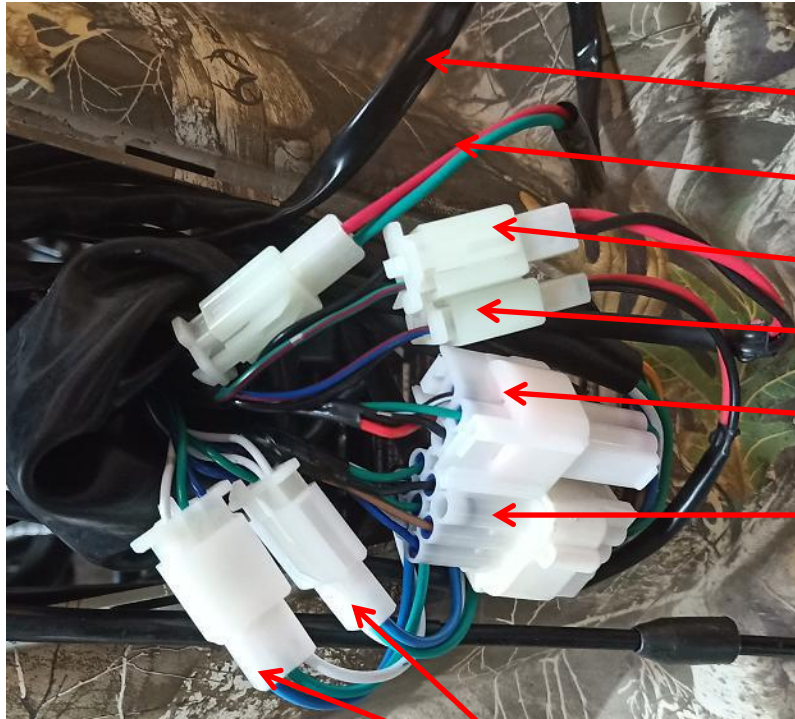

- Brake cable
- Stop switch
- Neutral display
- Reverse gear display
- Electrical lock
- Functional switch

Headlight

- Positive pole
- Negative pole
- Magneto connector

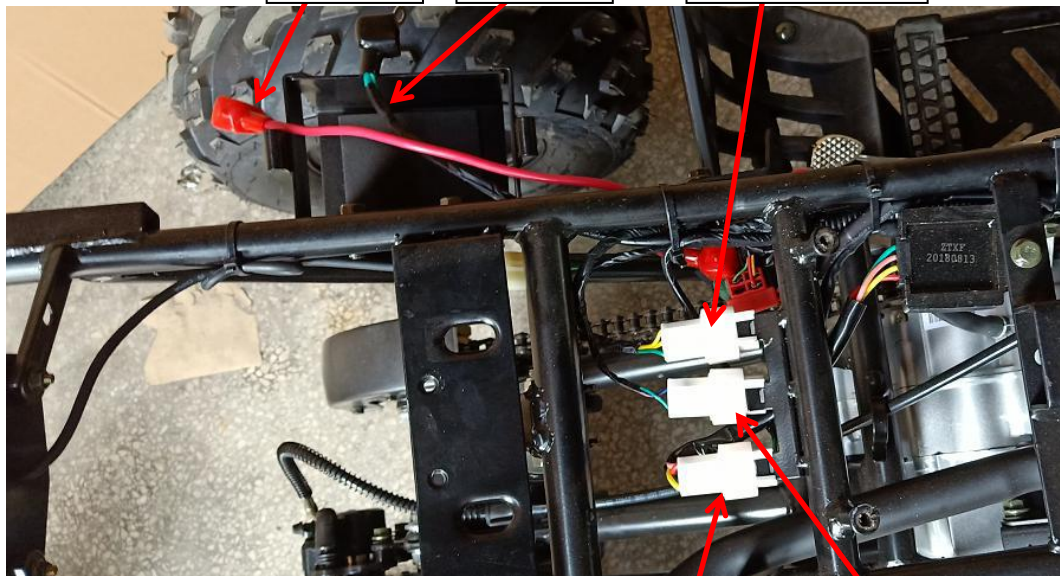

- Voltage regulator
- Gear indicator

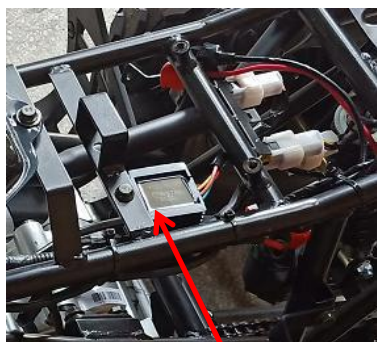

Voltage stabilizer



Rear light

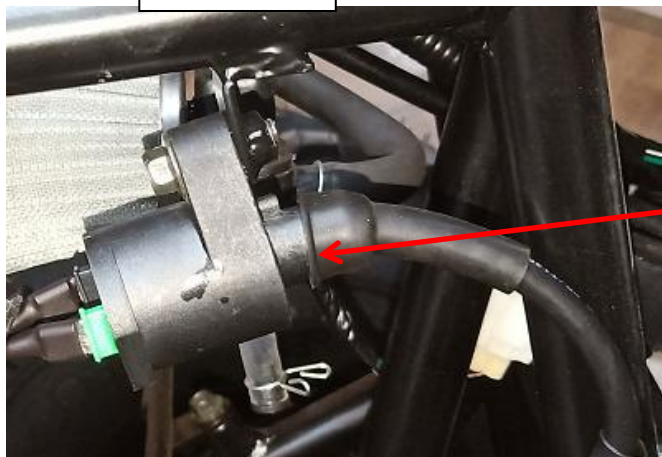

Ignition coil



CDI

2. Seat and rack

2.1 Seat

Disassembly

Lift up the seat hook 1

Lift up the rear of seat, and then pull it backward. 2

Remove the seat.



Installation

Take it back in reverse order from disassembly.

Check if the seat is installed in place and firm.



2.3.2 Front rack

Disassembly

Disassemble the mounting bolts from rack 1
(left and right each one)

Disassemble front rack 2



Installation

Take it back in reverse order from disassembly.

2.3.3 Rear rack

Disassembly

Disassemble mounting bolt from rear rack 1
(left and right each one)

Disassemble rear rack 2



Installation

Take it back in reverse order from disassembly.

3 Body covering

3.1 Maintenance cautions

3.2 Installation torque

3.3 Seat, front guard, clay, hood, rear body, left and right guard, front body, plastic pedal, dismantling left and right pedal

3.1 Maintenance cautions

Operation cautions

When replacing the covering parts, please stick the tags and riveting warning labels to the new covering.

This chapter is about the dismantling sequence of covering. When related coverings need to be disassembled to overhaul the internal parts of the vehicle, it can be carried out by referring to this chapter.

Pipe, inhaul cable should be equipped according to wiring diagram of cable, hosepipe and inhaul cable.

3.2 Installation torque

M8 bolt: 18~25N*m

TM6 bolt: 7~11 N*m

M6* bolt: 8~12 N*m

3.3 Hood, handlebar, seat, plastic parts (clay, rear body, left and right guard, front body), front guard, plastic pedal,

dismounting left and right pedal

3.3.1 Hood

Disassembly

① Remove the front display lampshade retaining bolts 1
Remove the front display lampshade 2

② Remove hood retaining bolts 3
Pull the hood in the direction shown in the picture, and remove the hood after the buckle is loosened (Note: the buckle on the hood is easy to break with caution)

Installation

Take it back in reverse order from disassembly.

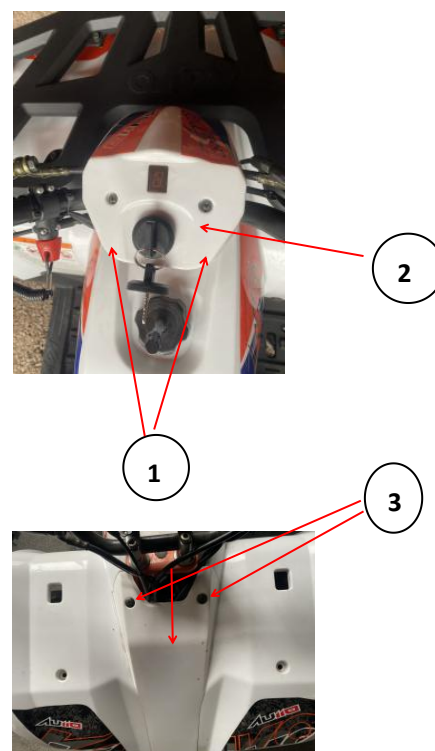

ZHEJIANG KAYO MOTOR CO., LTD.

After installation, pay attention to check whether the seat cushion is installed in place and firmly.

(Note: if the buckle is broken, replace it in time)

3.3.2 Handlebar

Disassembly

1. Cut off power first.
2. Cut plastic ties first, then pluck functional switch, stop switch and brake cable plug in sequence.
3. Loose the fixed bolt from brake bar by tool and remove rear brake bar.
4. Remove front brake bar as the same as rear brake bar.
5. Pull the damper cable as picture shows, then remove it.
6. Remove the bolt from accelerator cap to remove the throttle cable.
7. Dismounting fixed bolt, then the lower raiser, remove handlebar at last.

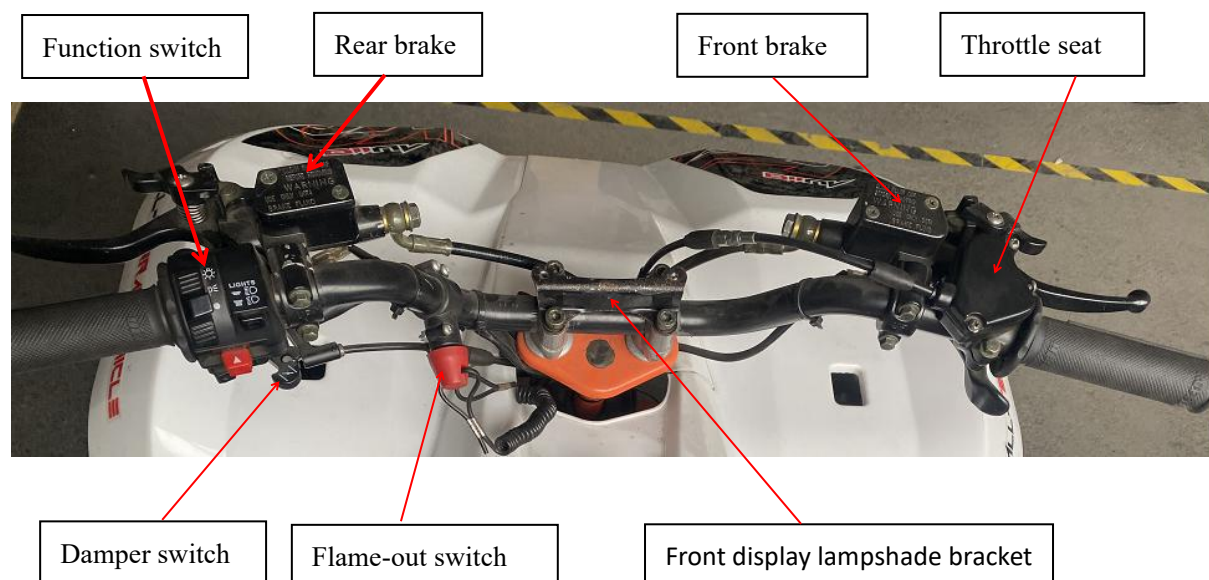

Installation

Take it back in reverse order from disassembly, then check if it installed well.

(note: 1. after installation, check the flame-out switch connector, function switch connector, brake connector etc., in case of misconnection or looseness.

2. Check if the dumper cable and throttle cable in right position.

3. Front and rear brake in right position, the wiring way refers to the vehicle wiring diagram.

3.3.3 front guard

Disassembly

1. Disassemble mounting bolt in order.
2. Remove the front guard.



Mounting bolt

Installation

Take it back in reverse order from disassembly

(note: if the mounting bolt or nut is broken, replace it to same specification in time)

3.3.4 Plastic parts

Disassembly

1. Disconnect electric plug, neutral indicator plug, reverse indicator plug and headlight plug.
2. Disassemble plastic parts fixing bolts 1/1, 2/2, 3/3, 4/4, 5/5, 6/6, 7/7, 8
3. Twist the oil cap, remove the plastic parts.
(note: remove the handlebar and hood first before dismount plastic parts.)

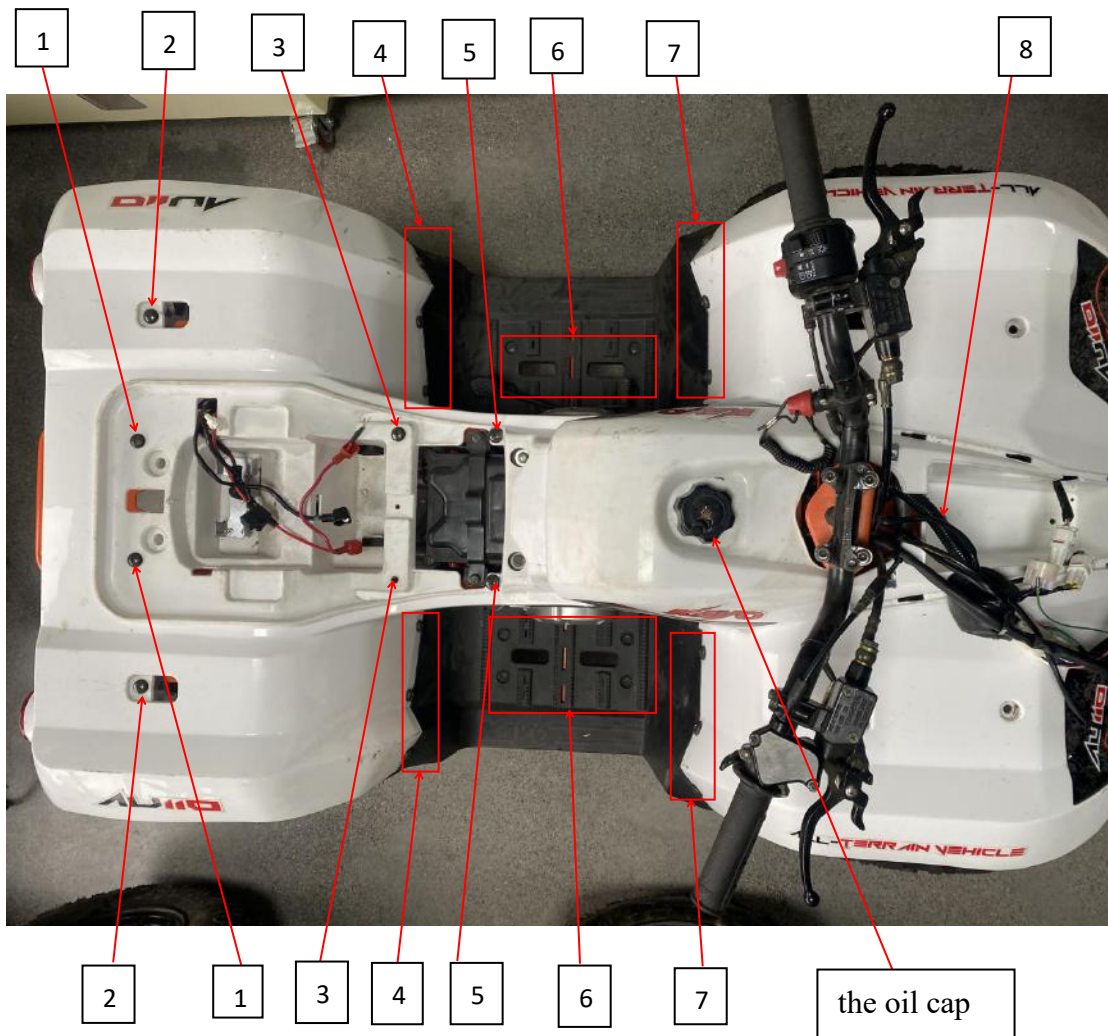

Take it back in reverse order from disassembly

(note: if the mounting bolt or nut is broken, replace it to same specification in time. After installation, check headlight connector, electric connector, reverse indicator connector etc., in case of looseness or misconnect.

4. Regular maintenance and adjustment

4.1 Maintenance information

4.2 Maintenance period

4.3 Inspection ways

4.4 Steering column and brake system

4.5 Wheel

4.6 Suspension system

4.7 Gear box and fuel system

4.8 Throttle check

4.9 Light device

4.10 Shock absorber selection

4.1 Maintenance information

Operation cautions

Note:

- Do not let the engine long running in airtight spots and unventilated places, because the exhaust contains carbon monoxide (CO) and other toxic components.
- In case of scald, don't touch the engine when the engine just stops working. If it must be, please wear long sleeves work clothes and gloves.
- As gasoline is flammable and explosive, it is strictly prohibited to set off fireworks in the work site. Pay attention to sparks as well as open flames. Vaporized gasoline may explode, please choose well-ventilated sites.
- Being careful of drive system and rotary parts, don't let them pinch your hands and clothes.

Note:

Keep the vehicle in a flat and stable place.

4.2 Maintenance period

Engine maintenance is a regular periodic work, according to a certain time interval for engine maintenance is very important, standard maintenance is helpful for well engine performance, reliable work, economic and durable, the following is the A125 engine maintenance period table.

Note: the contents in the table is based on normal condition, if in bad condition, the period should be shorter.

A: adjustment	10 hours or 300km
C: clean	20 hours or 750km

ZHEJIANG KAYO MOTOR CO., LTD.

			per 50 hours or 1500km			Remark
			per 100 hours or 3000km or one			
			per 200hours or 6000km			
			2 years			
Engine						
Lubricating oil and air filter		R		R		
Damper adjustment		I, A		I, A		
Engine leakproofness	I			I		
Engine suspension	I			I		
Air filter		C	R			
Sparking plug		I		I	R	
Fuel system						
carburetor	I			I, L		
Driving wheel, driven wheel				I, C		
clutch				I		

Item			Period					Criterion
Parts	Item	Daily	year	Half	year	One		
Steering device	Steering	Operating flexibility	○					
	Steering system	Damage	○					
		Installation status of	○					
		Ball pin shaking	○					
Braking device	Brake pedal	Pedal travel	○	○				
		Braking effect	○	○				
	Connecting	Slackness, looseness and	○			○		
	Hydraulic brake and brake disc	Brake fluid	○	○			○	Above the brake fluid lower limit
		Tear and damage of brake disc	○	○			○	Replace the disc in time, when front or rear brake working disc's thickness is less than 3mm.
	Brake pad	Tear and damage of brake pad	○	○			○	The minimum brake pad (friction plate) thickness ≥ 1.5mm ; less than 1.5mm, replace it.
Driving device	Wheel	Tyre pressure	○	○			○	Front wheel: 45kPa (0.45kgf/ cm ²) (4.0PSI) rear wheel: 45kPa (0.45kgf/cm ²) (4.0PSI)

ZHEJIANG KAYO MOTOR CO., LTD.

		Crack and damage of	<input type="radio"/>	<input type="radio"/>	<input type="radio"/>	
		Tyre groove depth and abnormal wear	<input type="radio"/>	<input type="radio"/>	<input type="radio"/>	If there's no tear indicator on the wheel, the residual groove depth should greater than 3mm
		Loose of wheel nut and	<input type="radio"/>	<input type="radio"/>	<input type="radio"/>	
		Front wheel bearing	<input type="radio"/>	<input type="radio"/>	<input type="radio"/>	
		Rear wheel bearing	<input type="radio"/>	<input type="radio"/>	<input type="radio"/>	
Buffer device	Suspension	Shaking of connection part	<input type="radio"/>	<input type="radio"/>	<input type="radio"/>	
	Damper	Leakage and damage	<input type="radio"/>	<input type="radio"/>	<input type="radio"/>	
		Function	<input type="radio"/>	<input type="radio"/>	<input type="radio"/>	
Transmission	Chain	Transmission and lubrication, tightness	<input type="radio"/>	<input type="radio"/>	<input type="radio"/>	Chain flapping>20mm
	Flywheel, chain wheel	Transmission and lubrication,tightness of fixing bolt	<input type="radio"/>	<input type="radio"/>	<input type="radio"/>	If chain wheel and chain wear severity, replace it.
Electrical device	Ignition device	State of spark plug	<input type="radio"/>	<input type="radio"/>	<input type="radio"/>	
		Ignition period	<input type="radio"/>	<input type="radio"/>	<input type="radio"/>	
	Battery	Terminal connection status	<input type="radio"/>	<input type="radio"/>	<input type="radio"/>	
	Electric circuit	Looseness and damage of	<input type="radio"/>	<input type="radio"/>	<input type="radio"/>	
Fuel device		Fuel leak	<input type="radio"/>	<input type="radio"/>	<input type="radio"/>	
		Throttle condition	<input type="radio"/>	<input type="radio"/>	<input type="radio"/>	Throttle knob clearance:
Lighting device and steering indicator		function	<input type="radio"/>	<input type="radio"/>	<input type="radio"/>	
Exhaust pipe and muffler		Whether the installation is loose or damaged	<input type="radio"/>	<input type="radio"/>	<input type="radio"/>	
		Function of muffler	<input type="radio"/>	<input type="radio"/>	<input type="radio"/>	
Frame		Looseness and damage	<input type="radio"/>	<input type="radio"/>	<input type="radio"/>	
Other		state of grease in frame each part	<input type="radio"/>	<input type="radio"/>	<input type="radio"/>	
Exception can be indentified in operation.		Make sure relevant parts are normal.	<input type="radio"/>	<input type="radio"/>	<input type="radio"/>	

4.4 Steering column and brake system

Keep vehicle in steady place and hold handlebar firmly as it shown in the picture to check if it's shaking.



If there is a shaking, check it's caused by steering column or other parts then repair.

If it's caused by steering column, fastening the lock nut on steering column, or you can also disassemble the steering column.

Keep vehicle in steady place and turn the handlebar slowly to check if it smoothly.



If it inflexible, check the main cable, inhaul cable and brake oil tube, if there is no problem, take a look at sleeves in the end of steering rod to see if its

blocked or damaged.

Note: the steering handlebar must be smoothly, or it may cause accidents due to out of control.

Clearance for front and rear handlebars: Check the effect and movement before operation. The clearance is 5-10mm.

Front brake pump assembly

Check the liquid volume. When the brake fluid volume decreases to the lower limit, stop using the vehicle. It is necessary to check the leakage of the brake pump, brake tube and all connections, if they are all normal, then open the pump cap of brake and inject DOT4 brake liquid to limit position.



Note:

- When adding brake fluid, do not mix with dust and water.
- In order to prevent chemical changes, please choose the specified brand of brake fluid.
- As brake fluid will damage the plastic and rubber surfaces, please do not splash it on the parts.

Front brake disc and brake block <wear of brake block>

The brake pad(clamp) and disc would be wearied to some extent, it's formal.

Check or replace the brake disc

- Check the surface of brake disc, if it is wearied or damaged, replace it.
- If the disc thickness is less than 3.0mm, replace it.

Check or replace brake block <wear of brake block>

- Check the minimum thickness of block, If it's less than 1.5mm, replace it.
- Check it there is damage or crack, if it has, replaces a new one.

Note: the brake block is complete change.

4.5 Wheel

Lift the front wheel with the tool in a horizontal position, and make sure there is no force on the wheel. Shake the front wheel left and right to check whether the connection of the front wheel is firm and if there is shaking. If it's shaking, check and fasten the rocker arm, axle, rim bolt and nut. If there is still a shaking, check and replace the bearing, ball pin, buffer sleeves of rocker arm.



Front wheel toe-in

Put the car body in a horizontal position and measure the size of the front wheel toe-in. The front wheel relative to the forward direction of the vehicle is: A in front and B behind the wheel
Toe-in size: $B-A=4 \sim 10\text{mm}$

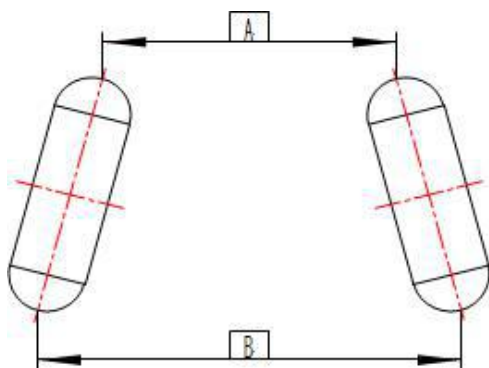

If not in this range, adjust steering rod, adjust the wheel toe-in to 4~10mm, locking.

Note: after the adjustment of front toe-in size, drive the vehicle slowly until it can control the direction.

Tyre pressure

Check the tyre pressure with a barometer. (pressure range: 4~6PSI)

Note: Checks the tire pressures while the tire in cool state. If the tire pressure is not suitable for the use of the state, it will influence the operation and ride comfort, and causing adverse effects such as tire bias wear.

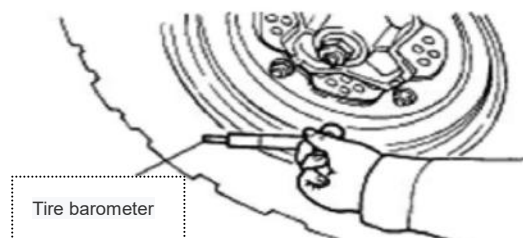

Wheel pattern

Check wheel pattern, if the thickness is less than 3mm, replace it.

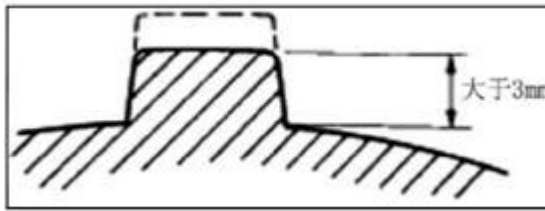

The inspection of rear wheel is the same as front wheel.

4.6 Suspension system

Keep vehicle in a horizontal position and compress up and down for several times according to the pictures. If there is shaking or abnormal sound, check whether there is oil leakage in the shock absorber, and whether there is damage or loosening in the fastening parts.



4.7 Gear box and fuel system

Change gear, check if the gear box is flexible and if it in shift position. If it's inflexible, adjust the angel of gear box rod.



Fuel device

Remove the plastic parts first.

Check fuel pipe for aging and damage. Replace the fuel pipe when it is aging or damaged add. Check the adsorption tube of the fuel evaporation system for cracks and bends, and replace with a new one if there is any damage.

4.8 Throttle check

Check the free stroke of the throttle button. Press the accelerator several times according to the direction shown in the diagram, and check the degree of freedom of the accelerator. Under normal circumstances, there is no sticky phenomenon of the accelerator naturally.



Clearance: 3~5mm

When the clearance is not within the range, it shall be adjusted.

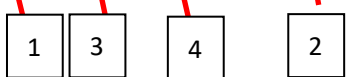

Remove sleeve for 1/2, adjust regulator 3, then turn the throttle to normal free stroke. Tighten the nut 4, install sleeve back.

If the above method is useless, replace a new throttle cable.

Speed limiting device adjustment(EPA state is not suitable)

Speed limit device is used for restrict throttle opening.

Inspect the thread length limit of speed limit screw. Thread length $a=25\text{mm}$

Adjustment: Loosen the lock nut, then adjust it with a phillips screwdriver.

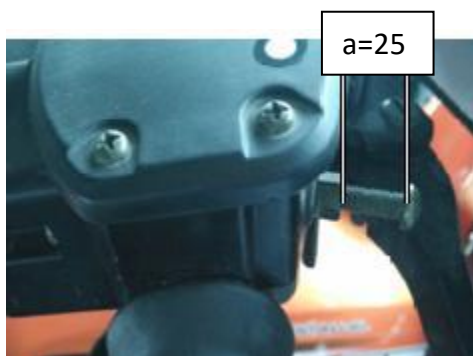

Note: For beginners, the speed limiter should be in a tight position and until the technology has reached a certain level it can be changed.

Besides, the thread length limit is 25mm. This speed limiter is fixed in EPA state, after being adjusted by the manufacturer, screw off the bolt and change it into an unadjustable state.

Selection of front and rear shock absorbers

Front brake is unadjustable.

Rear brake can be adjust from 1 to 5. the factory default state is gear 3. It can be adjusted according to rider's needs for riding comfort.

Adjustment:

1. By absorber adjusting wrench (crescent).
2. Turn left the absorber get soft and right it will get hard.



Absorber adjusting wrench

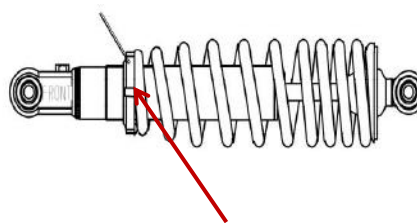
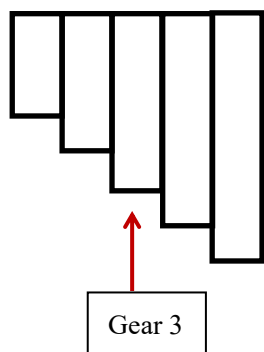

adjust the softness and hardness of absorber

5. Places around engine

5.1 Maintenance information

5.2 Fuel system

5.5 Disassembly and installation of engine

5.3 Air intake system

5.4 Exhaust system

5.1 Maintenance information

Precautions

- Before operation and maintenance, please ensure that the vehicle is shut down and static for no less than 1 hour, and make sure that the heating parts are cooled, so as to avoid injury.
- Do not damage the frame, engine body, bolts and cables during maintenance.
- In order to protect the engine frame, please wrap the engine before operating.
- When the engine is removed, the corresponding containers should be prepared to receive coolant, oil and fuel oil for environmental protection, and the coolant and oil should be supplemented as required during installation.
- The engine doesn't need to remove in following operations.
 - oil pump

- carburetor, air filter
- cylinder head cover, start motor, cylinder head, cylinder block, camshaft
- left cover, AC magneto
- piston, piston ring, piston pin
- Remove the engine in following operations.
 - Crankshaft, main and counter shaft

Tightening torque

See 1.5

5.2 Fuel system

Note

Gasoline is flammable; fireworks are strictly prohibited in workplace. Not only open fire, but also electric spark shall be given high attention.

Besides, as there is a risk of explosion after the evaporation (vaporization) of gasoline, the operation should be carried out in a well-ventilated place.

Disassembly

When disassemble the plastic parts, loose the tube 1 of oil throttle, then dismount the oil switch bolt 2 and remove switch, remove tank mounting bolt last.



Oil tube
1

Oil switch bolt
2



Tank mounting bolt

5.3 Air intake system

Disassembly

1. Remove air filter retaining bolts.
2. Remove the air filter retaining bracket.
3. Loosen the the exhaust pipe and the clamp of the air filter, then remove the air filter (Note: remove the handlebar and the front body before removing the air filter)

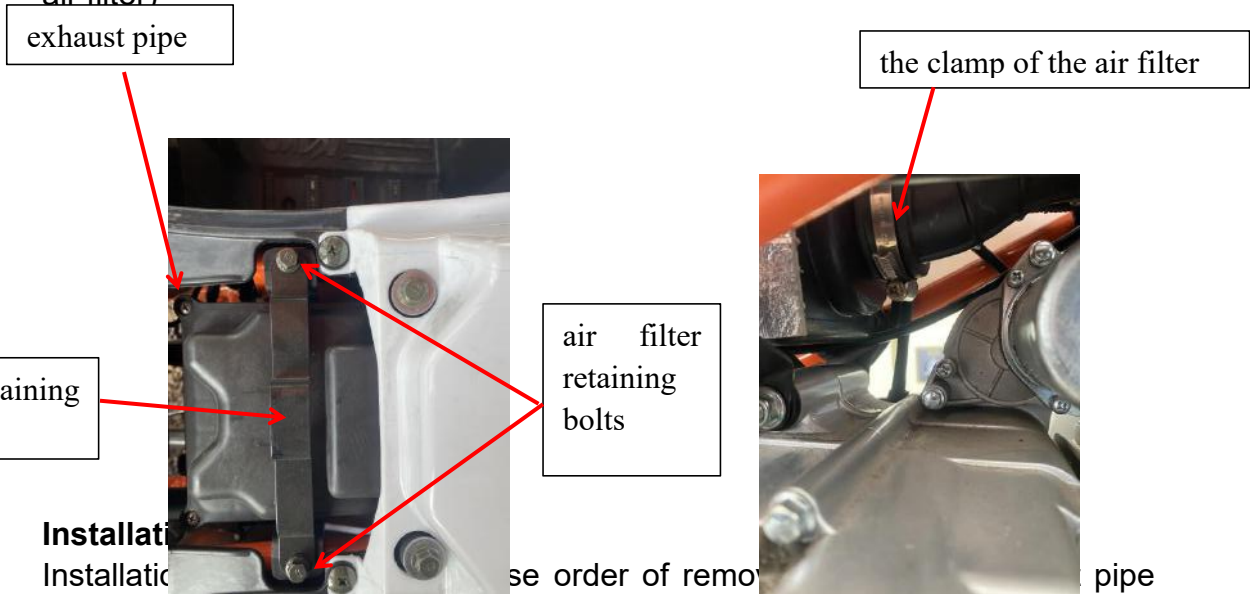

Installation

Installation should be done in the reverse order of removal. The exhaust pipe connect with the connector head and clamp connect with pipe groove.

5.4 Exhaust system

Disassembly

Disassemble the connected clamp between muffler and exhaust pipe, then remove the muffler mounting bolt to remove muffler.

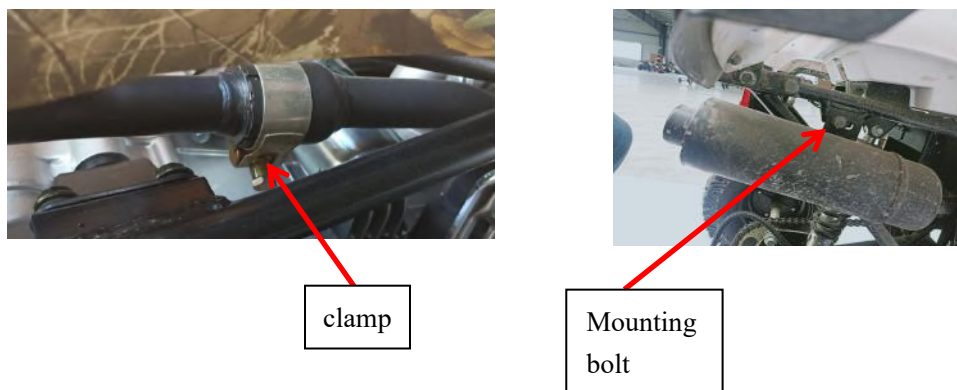

Remove the self locking nut 3 between exhaust mouth and exhaust pipe, then remove exhaust pipe.



Disassembly

Installation shall be in the reverse order of removal. Note if exhaust pipe seal pad 4, graphite sleeve 5 for muffler mounting and locking nut damaged, replace at once.

5.5 Disassembly and installation of engine

Disassembly (Note: Remove pedal first)

1. Remove the engine side cover retaining bolts 1 first , then remove chain.

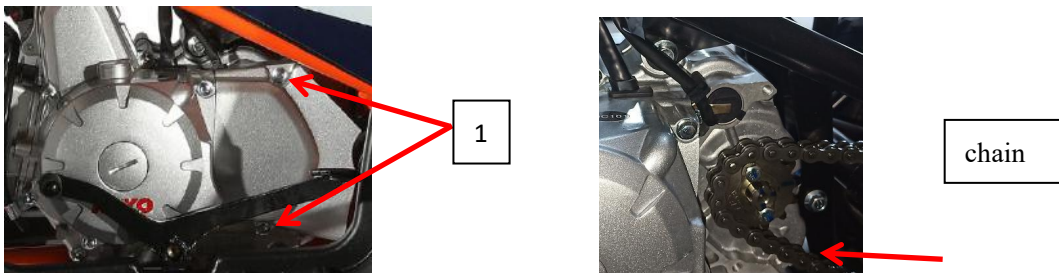

2. Remove the ground lead, gear indicator cable, magneto cable, start motor cable, exhaust pipe, ignition coil cap and gearshift.

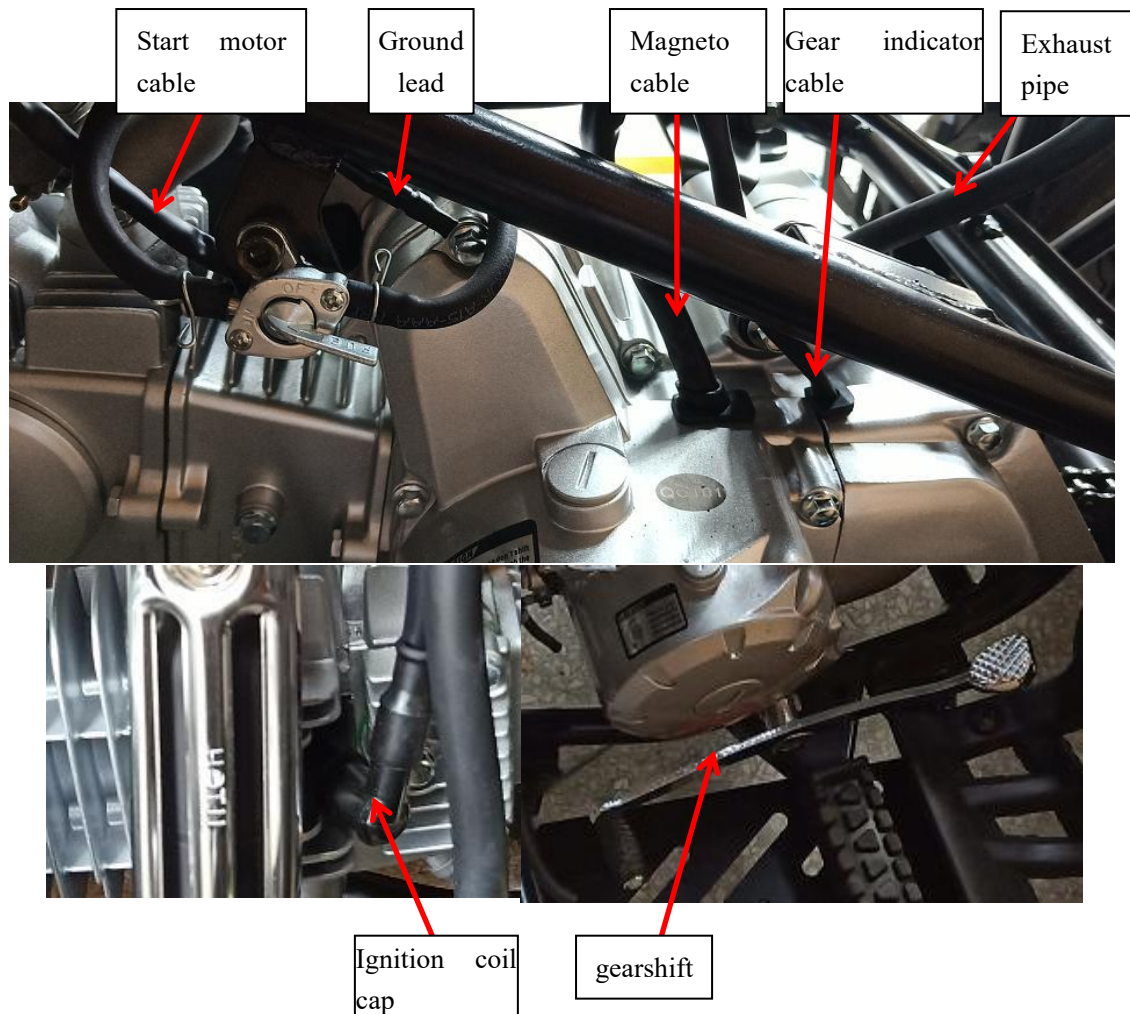

3. Remove the power bolts, lug, and bolt of engine bottom.

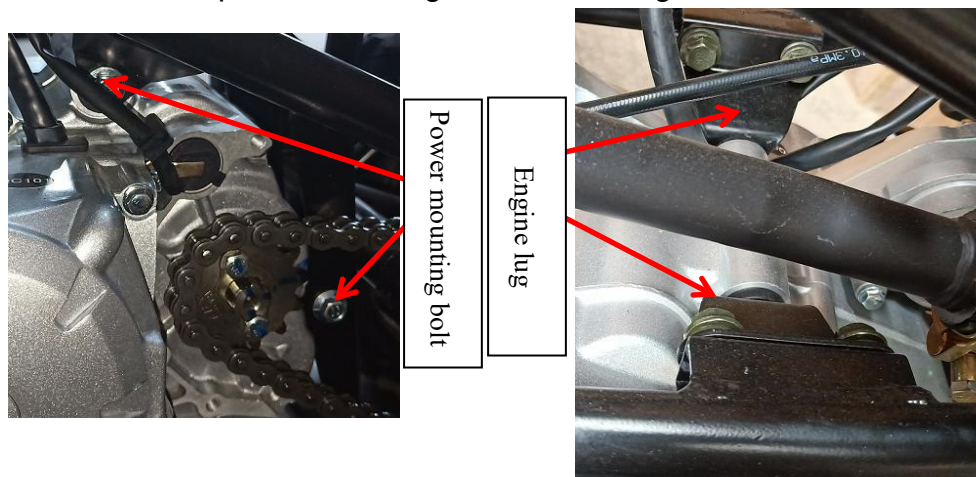

4. Remove the engine from the right side of vehicle.

Installation

Installation shall be in the reverse order of removal.

6 Engine

6.1 Maintenance information

Conversion table refers

Item	Unit conversion
Pressure	1kgf/cm ² =98.0665kPa 1kPa=1000Pa 1mmHg=133.322Pa=0.133322kPa
Torque	1kgf·m=9.80665N·m
Volume	1mL=1cm ³ =1cc 1L=1000cm ³
Moment	1kgf=9.80665N

Danger/warning/attention

Take it seriously, it's important for maintenance.

Danger: Be on high alert for danger.

Warn: to be alert to moderate danger.

Attention: to be alert to minor danger.

This manual may doesn't contain some potential risks in engine work and maintenance; the service operator should also have basic mechanical knowledge. If you are not sure about completing the entire repair operation,

please consult a more experienced senior technician.

General precautions

Warning:

Proper maintenance is very important to engine reliability and personnel safety.

- When there is two or more people work together, more attention should be paid for safety.
- When starting the engine indoors, be sure to vent the exhaust outside.
- If toxic or flammable substances are used, handle that in accordance with the manufacturer's instructions strictly and make sure workplace must be well ventilated.
- Don't use gasoline as a cleaning fluid
- To avoid burns, do not touch uncooled engine oil, exhaust system parts
- If the fuel, lubrication and exhaust systems are serviced, please check the marker and leakage.
- In order to protect the environment, oil replacement parts can't be disposed.

Warning:

- **If parts need to be replaced during maintenance, please choose parts which recommended or provided by Kayo.**
- **Disassembled parts that need to be reused should be arranged in order, it's helpful to assembly.**
- **Choose special tools as specified in the maintenance manual.**
- **Ensure that parts used in assembly are clean and must be lubricated where required.**
- **Use special lubricants, binders and sealants.**
- **When fastening bolts, screws and nuts, first tighten the large size, and tighten from inside to outside according to the specified torque.**
- **Use a torque wrench to tighten the torque required bolts, if there is grease and oil on the thread, it must be erased.**
- **Clean the disassembled parts before inspection and measurement.**
- **After assembly, check the fastening and running status of components**
- **Do not use the removed oil seal, o-ring, gasket, self-locking nut, lock washer, cotter pin, elastic baffle and other parts.**

6.2 Engine oil and fuel

Fuel: Use octane 93# or higher unleaded gasoline

Engine oil: Use sae15w-40 oil for 4 stroke motorcycle, quality grade according to the classification of the API SG level or by the superior, if no SAE15W - 40 oil, according to the engine using the environment temperature, as the picture on the right is shown.

Warning: Engine oil shall not be mixed with engine oil of other brands

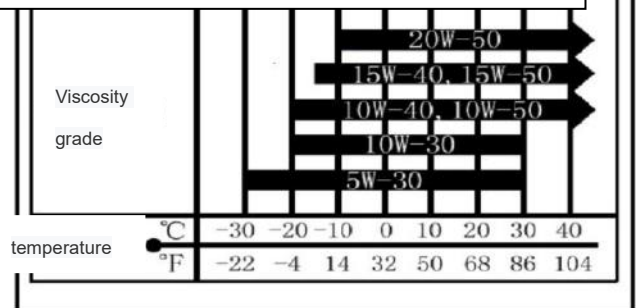

6.3 Engine brake-in

Engine has a lot of relative motion components, such as piston, piston ring, cylinder block, mutually meshing transmission gear wheel, etc. therefore, a standard break-in is very important at the beginning of its use, it can make the moving parts to adapt to each other, correction work, form good heavy load to bear a smooth friction surface. Through this process the engine will have excellent performance and reliability. Recommended break-in time: 20 hours, details as follows:

0~10 hours

Avoid continuous operation, constantly changing speed and not operating in a fixed throttle position when the throttle is more than 50%; Cool the engine for 5 to 10 minutes after each hour of operation. Avoid rapid acceleration, throttle change should be slow.

10~20 hours

Avoid operating longer than 3/4 throttle. Use freely but do not use full throttle.

6.4 Engine number



Engine head displacement label

Engine Number



6.4 Maintenance

Subsidiary

maintain times Items	Odometer reading			
	1000km	4000km	8000km	12000km
Fuel system	Clean	Clean	Clean	Clean
Oil filter	Clean	Clean	Clean	Clean
Control	Adjust	Adjust, clean	Adjust, clean	Adjust, clean
Carburetor	Clean	Clean	Clean	Clean
Air cleaner	Clean	Clean	Clean	Clean
Spark plug gap	Adjust	Adjust, clean	Adjust, clean	Adjust, clean
Valve clearance	Adjust	Adjust	Adjust	Adjust
Engine lubrication	Replace	Replace once per 2000km		
Filter media	Clean	Clean	Clean	Clean
Timing chain	Check	Adjust	Adjust	Adjust
Carburetor idle speed	Adjust	Adjust	Adjust	Adjust
Drive chain	Adjust and lubricate per 5000km			
Battery	Charge	Charge	Charge	Charge
Brake disc	Check	Adjust	Adjust	Replace 更换
Brake system	Adjust	Adjust	Clean	Clean
Brake light switch	Adjust	Adjust	Adjust	Adjust
Illuminating system	Check	Check	Adjust	Adjust
Clutch	Adjust	Adjust	Adjust	Adjust
Shock absorber	Adjust	Adjust	Clean	Clean
Nuts/bolts	Tighten	Tighten	Tighten	Tighten
Front and rear wheel	Check	Check	Check	Replace
Turn handlebar bearing	Check	Adjust	Adjust	Replace

6.4 Maintenance of Engine Body

6.4.1 Disassemble, assemble and maintain cylinder head

Right view of the 125 engine is shown in the figure.



right view of 125

Left view of the 125 engine is shown in the figure.



left view of 125

Remove the lock nut of cylinder head from its holding place.

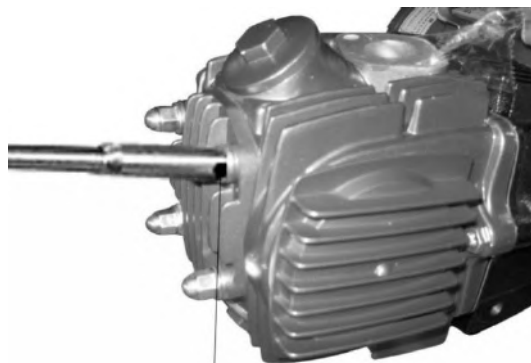

Locknut

Remove cylinder head. Check the state of paper pad. Replace if necessary.

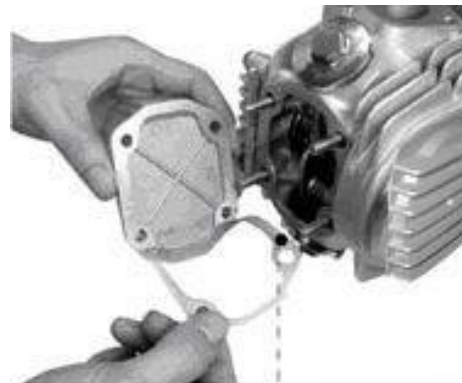

paper pad

Dismantle the fixing bolt of left cover.

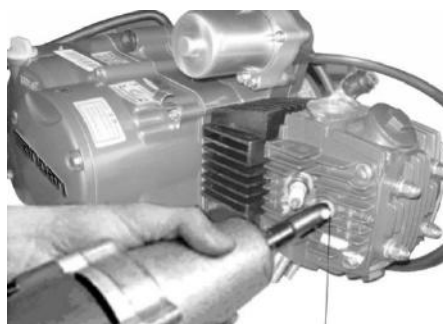

fixing bolt

Remove left cover and inspect the paper pad for damage. Replace if necessary.

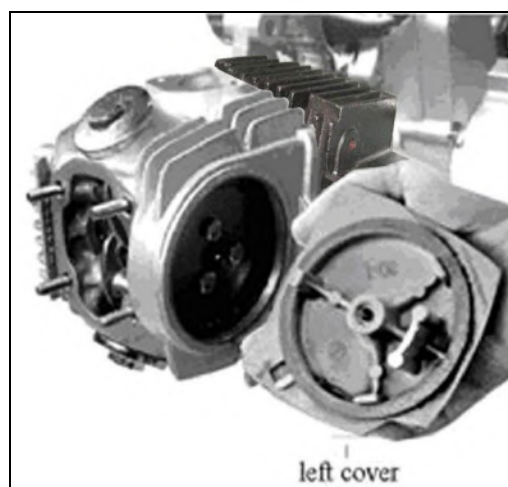

left cover

Dismantle the fixing bolt of right cover.

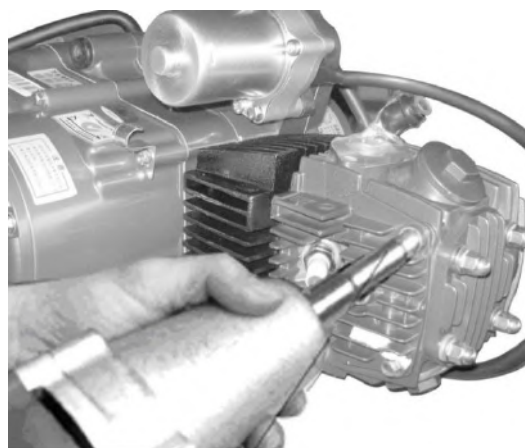

Remove the right cover of cylinder head. Inspect the gasket for damage

and replace if necessary.



paper pad

Remove inlet/exhaust valve cap. Check the state of seal ring of valve cap and replace if worn or if reuse is questionable.



valve cap

Remove the fixing bolt of timing driven sprocket.



fixing bolt

Remove the connecting bolt of cylinder head.

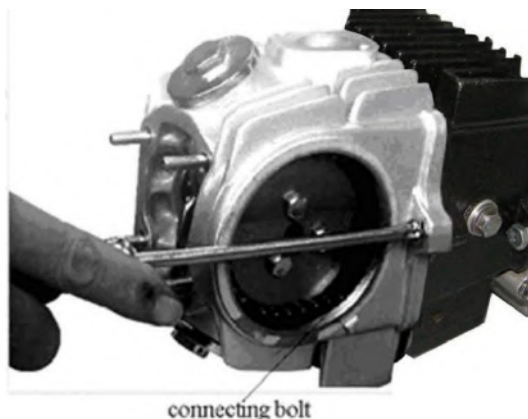

Remove cylinder head assembly.

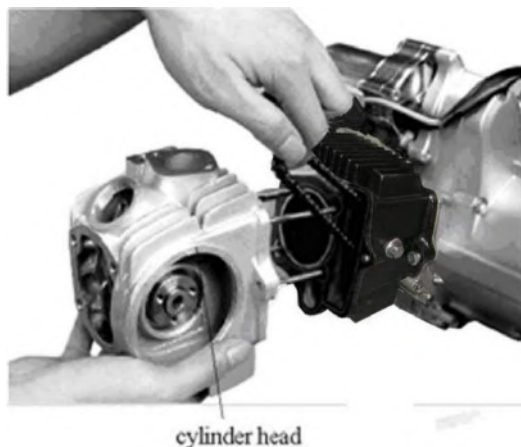

Remove timing driven sprocket. Inspect the timing driven sprocket for wear and damage. Replace if necessary.

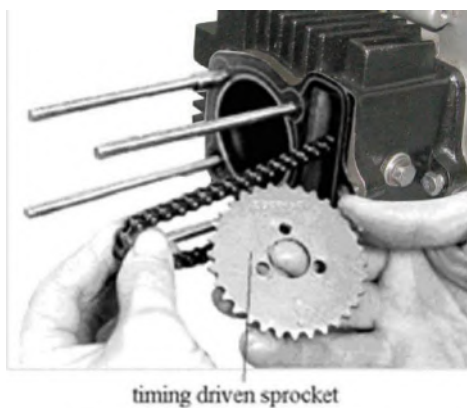

Check whether there is excessive carbon deposit in combustion chamber. Clean and replace if necessary.



Remove the cylinder head. Pour gasoline into inlet/exhaust pipe to inspect the seal condition. Grind the valve and valve seat if there is gasoline leak into the combustion chamber.



Remove inlet/exhaust valve spring and check the state. Replace if necessary.

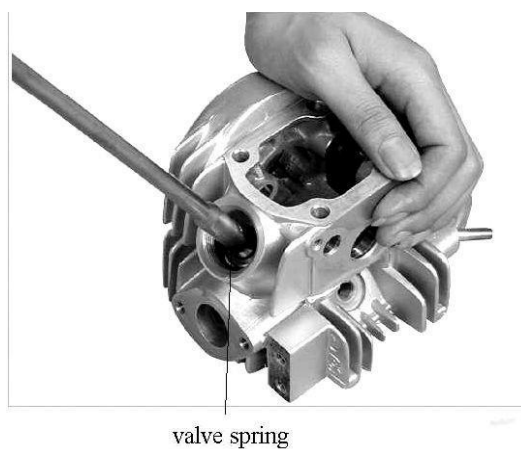

Inspect the oil seal of inlet/exhaust valve for damage. Replace if necessary.



cylinder head

Remove the spark plug to clean the carbon. Deposit and dust .Check the spark plug gap and set it to 0.6 to 0.7 if necessary.



spark plug

For the troubleshooting of cylinder head ,please refer to the following table

Description	Damage Form	Problem	Cause	Correction
Cylinder head	Too much oil dirt or sand on the cooling fins.	Poor heat radiation of the fins on cylinder head	The engine overheats	Remove the oil dirt or sand
	Carbon deposit in the combustion chamber	Overheating head	The engine overheats	Remove the carbon deposit
	Failure of sparking plug threaded hole	Air leakage between the sparking plug and cylinder head	The engine starts hard or fails to start	Repair the threaded hole or replace the cylinder head
	Serious deformation of cylinder head end surface	Air leakage between the cylinder head and cylinder	The engine starts hard or fails to start. Insufficient engine output; Engine speed changes during idle run	Grind the cylinder head end surface or replace the cylinder head
	There are pits, ablation or pock marks, damages on the working surface of valve seat.	Air leakage between the valve and valve seat due to improper tightness	The engine starts hard or fails to start. Insufficient engine output; engine speed changes during idle run.	Repair the valve seat
	The inner hole of valve guide is over worn.	The fitting clearance between the valve and the valve is too large.	Thick blue and white fume from the exhaust muffler pipe.	Replace the valve guide.
	The cylinder gasket is broken.	Air leakage between the cylinder head and cylinder.	The engine starts hard or fails to start. Insufficient engine output; Engine speed changes during idle run.	Replace the cylinder head gasket.

ZHEJIANG KAYO MOTOR CO., LTD.

	The fixing nut is not properly tightened.	Air leakage between the cylinder head and cylinder.	The engine starts hard or fails to start. Insufficient engine output; Engine speed changes during idle run.	Tighten the fixing nut.
Spark plug	Improper clearance between electrodes.	Weak or no sparking from the spark plug electrodes.	Oil leakage between the cylinder and crankcase.	Adjust electrode gap to 0.6~0.7mm.
	The spark plug electrodes are jointed by carbon deposit.	No sparking from the spark plug electrodes.	The engine starts hard or fails to star.	Remove the carbon deposit between the electrodes.
	Excessive carbon deposit or oil dirt in the spark plug.	Weak or no sparking from the spark plug electrodes.	The engine starts hard or fails to start. Insufficient engine output; Engine speed changes during idle run.	Remove the carbon deposit or oil dirt.
	The spark plug insulator is damaged.	Weak or no sparking from the spark plug electrodes.	The engine starts hard or fails to start. Insufficient engine output; Engine speed changes during idle run.	Replace with a new spark plug of the same type.
	The spark plug is not properly tightened.	Air leakage between the spark plug and cylinder head.	The engine starts hard or fails to start. Engine speed changes during idle run.	Tighten the spark plug.

6.4.2 Disassemble, assemble and maintain cylinder block

Remove cylinder gasket and dowel pin to check for wear and damage. Replace if necessary.

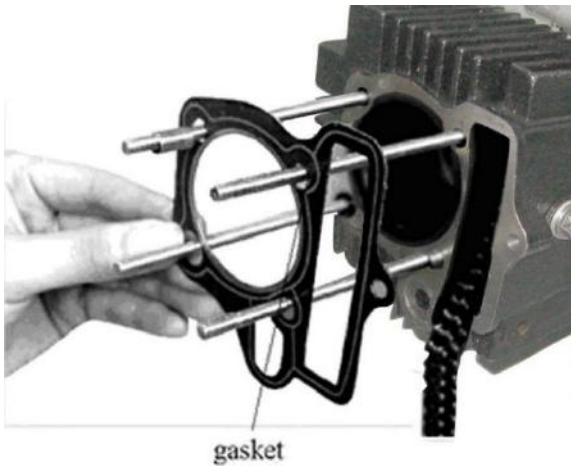

Dismantle connecting bolt of cylinder block.

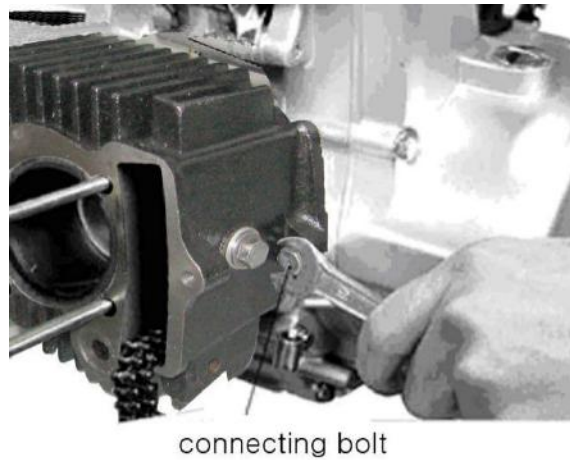

Dismantle the fixing bolt of timing chain of guide wheel.

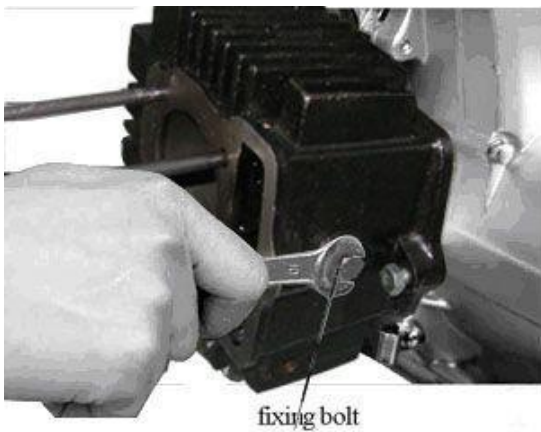

Remove the cylinder block.

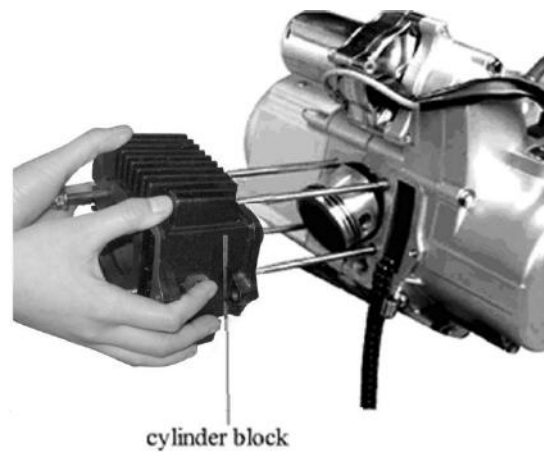

Remove the guide wheel of timing chain to inspect for wear and damage. Replace if necessary.

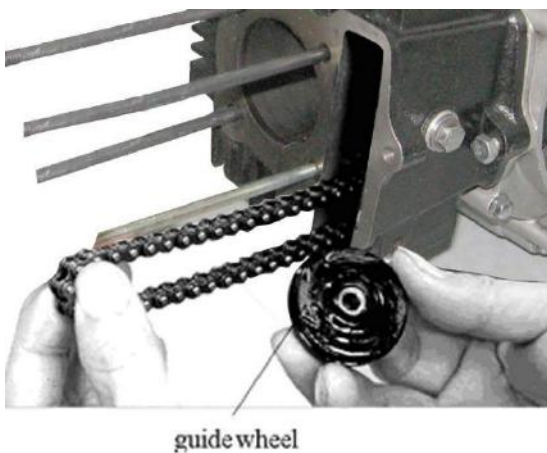

Remove the circlip of piston pin.

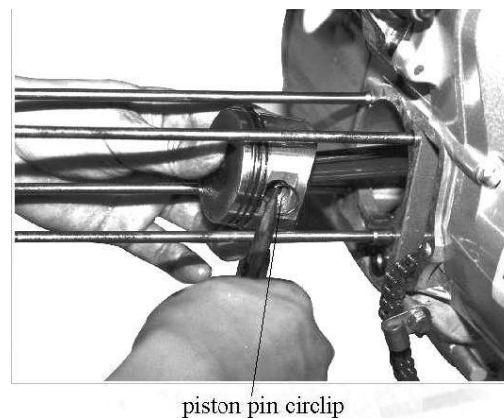

Remove the piston of piston pin to check whether it is damaged.
Replace if necessary.

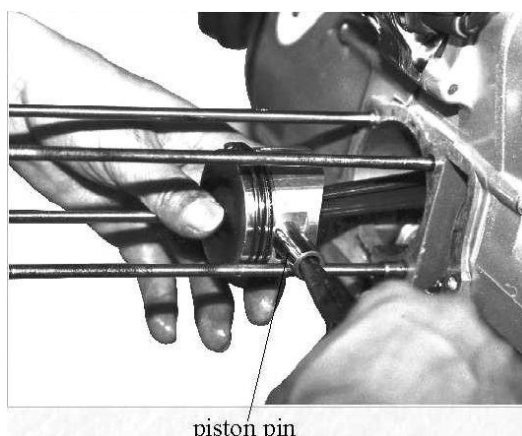

piston pin

Inspect the paper pad for worn or damage .Replace if necessary.

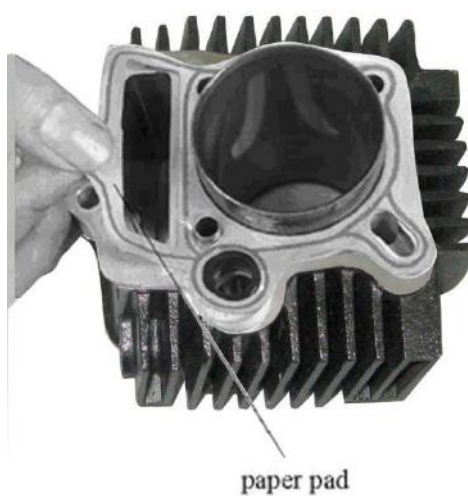

paper pad

Check whether there is residual gasket on cylinder. Clean with gasoline if necessary.



cylinder

Check the state of cylinder inner wall .Replace if worn or if reuse is questionable.



inner cylinder wall

Check whether the internal diameter has exceed the limit value. Measure the diameter form upper, middle and lower position. The limit value is 50.05mm.Replace the cylinder block if it has beyond this value.



cylinder block

ZHEJIANG KAYO MOTOR CO., LTD.

Troubleshooting of the cylinder body, please refer to the following table

Maintenance of Cylinder Body

Description	Damage form	Trouble	Cause	Correction
Cylinder body	Excessive oil dirt or sand on the radiating fins	Poor heat radiation of the fins on cylinder body	The engine overheats	Remove the oil dirt or sand
	Cylinder end surface badly distorted	Air leakage between the cylinder and cylinder head	The engine starts hard or fails to start .Insufficient engine output; poor idle speed and high fuel consumption.	Grind cylinder end surface or replace the cylinder body.
	The cylinder is badly worn.	The fitting clearance between the cylinder and position, position ring is too wide.	The engine starts hard or fails to start .Insufficient engine output; Poor engine idle speed. Thick blue and white fume form the exhaust muffler pipe.	Repair with boring machine or replace the cylinder body.
	The cylinder		Oil leakage between the cylinder and crankcase.	Replace the cylinder gasket.

6.4.3 Disassemble, assemble and maintain crankcase

Remove the cover of right crankcase half. Check whether the oil seal of starting shaft and seal edge of gearshift lever are worn. Replace if necessary.



starting shaft oil seal

Check the state of right crankcase cover and replace if necessary.

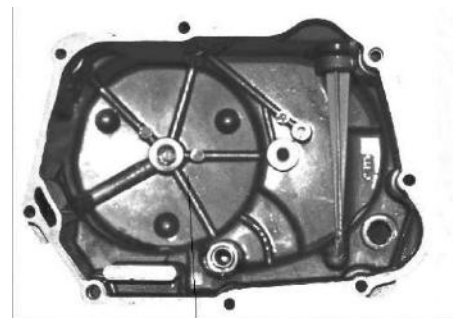

right crankcase cover

Left view of right crankcase half is shown in fig and check whether bearing of main shaft and counter shaft are worn. Replace if necessary.

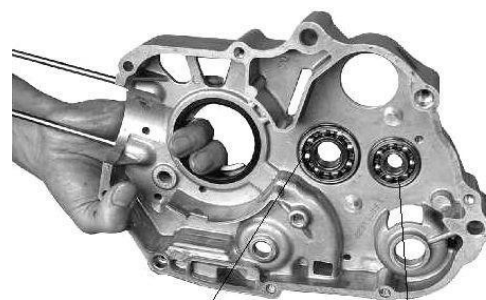

main shaft bearing

countershaft bearing

Right view of right crankcase half is shown in fig and check the state of right crankcase half. Replace if necessary.

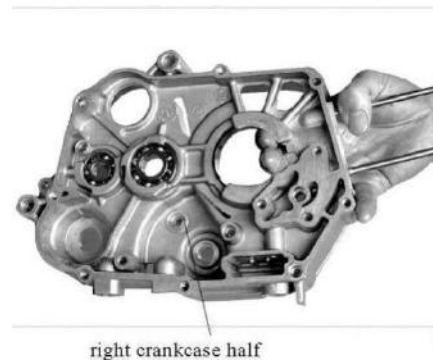

Left view of left crankcase is shown below and check whether the oil seal of counter shaft and oil seal edge of gearshift lever are worn. Replace if necessary.

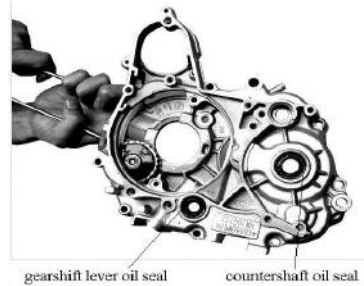

Right view of right crankcase half is shown in fig and check whether bearing of main shaft and counter shaft are worn. Replace if necessary.

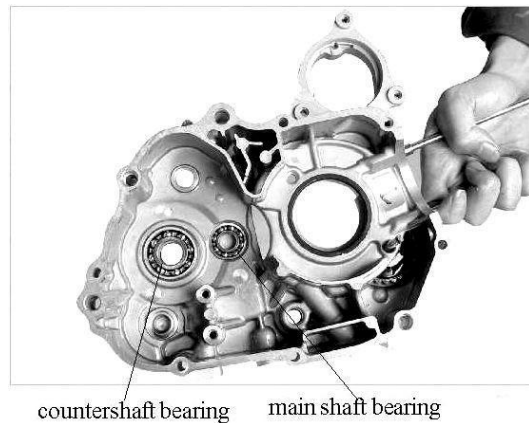

Dismantle fixing bolt of left crankcase cover.

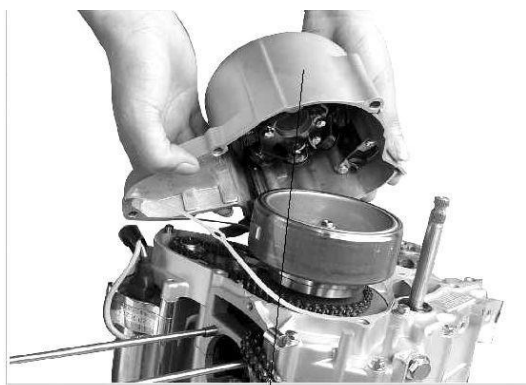

magneto stator

Remove the neutral indicator and check the state. Replace if necessary.



neutral indicator

Dismantle the fixing bolt of magneto stator and remove the.

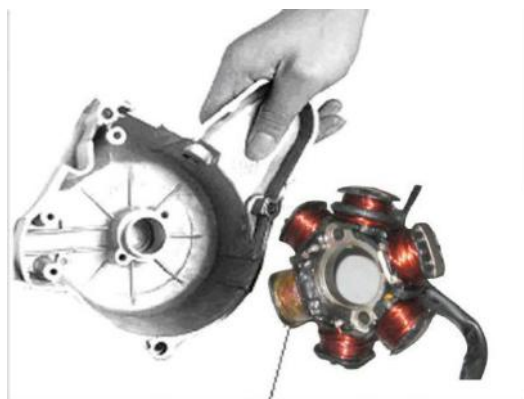

magneto stator

Check the condition of left crankcase cover and replace if necessary.

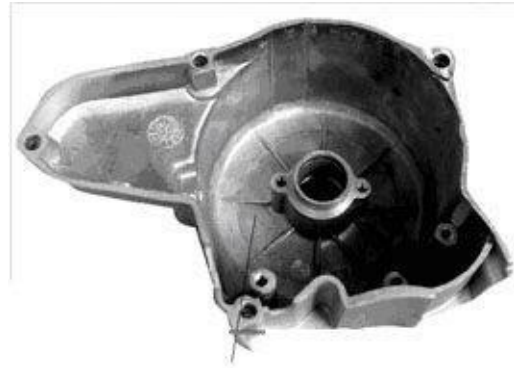

left crankcase cover

Troubleshooting of crankcase, please refer to the following table.

Description	Problem	Trouble	Cause	Correction
Crankcase	Crack in the crank case		Oil leakage from	Repair or replace
	Oil leakage from the joint of left and		The crankcase gasket is worn out	Replace the gasket
	The threaded hole of oil drain plug screw is		Oil leakage from the threaded hole	Repair of replace the crankcase
	The threaded holes of cylinder bolt are ineffective	Cylinder head retaining nut is impossible to screw up firmly, resulting in	The engine starts hard or fails to start. Insufficient engine output; Engine speed	Repair the threaded or replace the crankcase.
	The bolt of the	The same as front	The same as front	Replace the cylinder bolt
	The oil seal is damaged or the oil	Oil leakage is ineffective	Oil leakage from the oil seal	Replace the oil seal
Right crankcase cover	The right crankcase		Oil leakage form	Repair or replace
	The gasket of right crankcase is		Oil leakage between the case	Replace the gasket
Left crankcase cover	The left crankcase		Oil leakage form	Repair or replace
	The gasket of left crankcase is		Oil leakage between the case	Replace the gasket

6.4.4 Maintenance of Crankshaft Connecting Rod

Disassemble, assemble and maintain crankshaft connecting rod

Remove the fixing bolt of crankcase from its holding place.

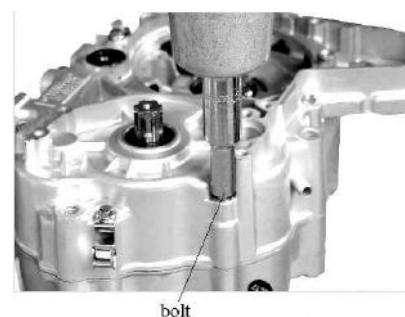

ZHEJIANG KAYO MOTOR CO., LTD.

Remove left crankcase half. Take care not to forget the washer of main shaft and counter shaft when removing the left crankcase.

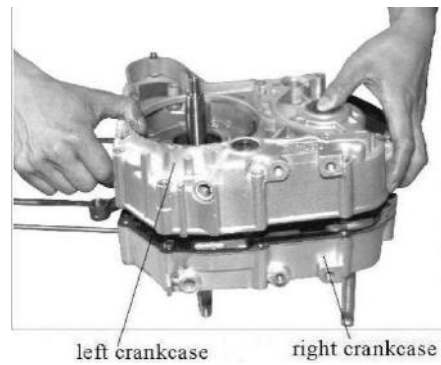

Remove the paper pad to inspect for wear and damage. Replace if necessary.



Remove the connecting rod assembly.



Inspect connecting rod bearing for wear and damage. Replace if necessary.

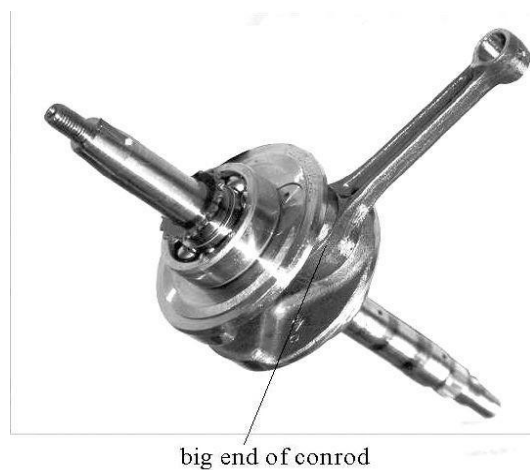

Check gap of big-end of connecting rod. Reset the gap if necessary.

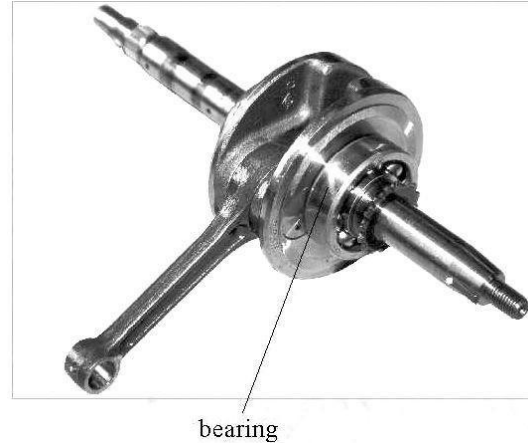

Check diameter of piston pin using a micrometer. Replace the piston pin if the value is over the maintenance limit value.

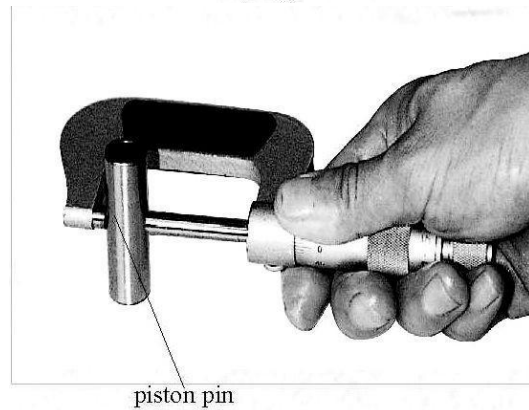

Check the axial and radial jumping of connecting rod bearing. Replace the conrod if the jumping is large

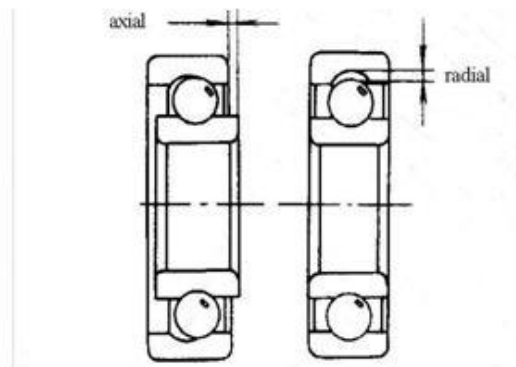

Check the side gap between piston ring and piston groove using a feeler gauge. Replace the piston if the gap is too wide.

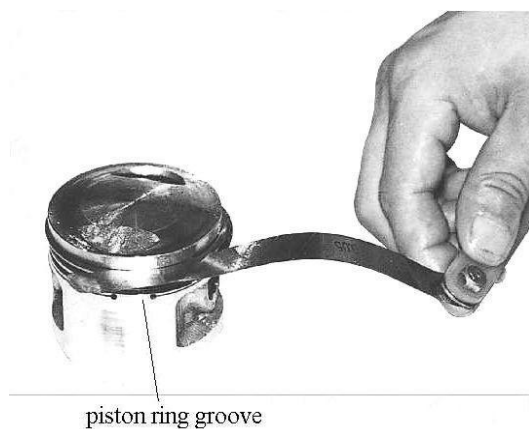

ZHEJIANG KAYO MOTOR CO., LTD.

Check whether there is excessive carbon deposit on piston top and groove.
Remove it if necessary.

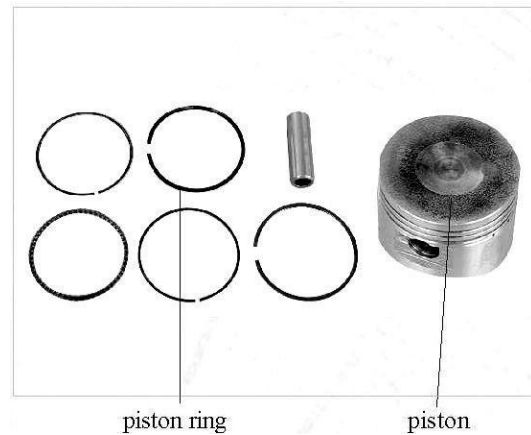

Check the state of piston and replace if worn or if reuse is questionable.
Measure diameter of piston skirt.
Replace it if the value is beyond the maintenance limit value.

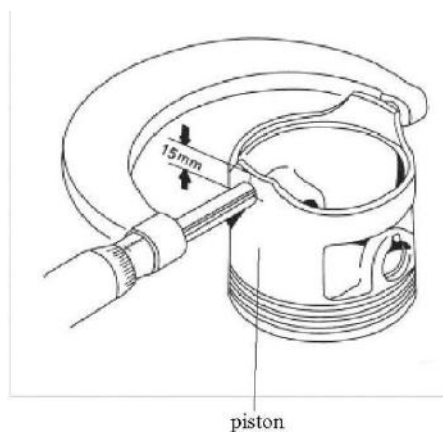

Assemble the piston ring according to the figure and check whether piston ring is damaged or the elasticity is weakened. Replace if necessary.

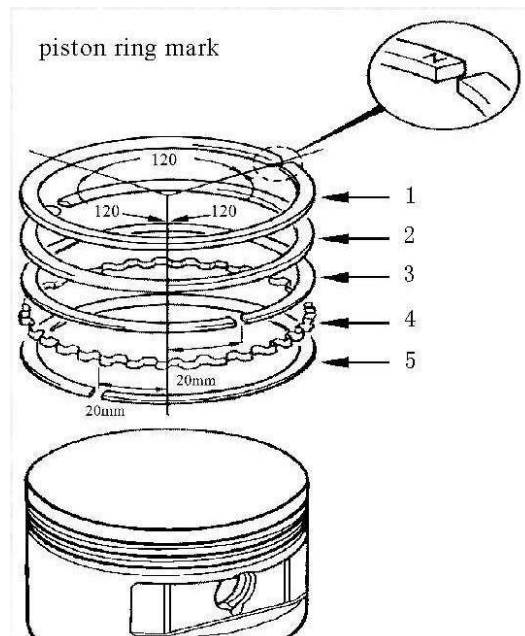

For the troubleshooting of crankshaft connecting rod mechanism, please refer to the following table.

Maintenance of Crankshaft Connecting Rod Mechanism

Description	Damage from	Trouble	Cause	Correction
Piston	Carbon deposit on		The engine over- heats	Remove the carbon deposit
	Carbon deposit in the ring groove	The piston ring is seized in ring groove	The engine starts hard or fails to start. Insufficient engine output; Thick blue and white fume form the exhaust muffler pipe.	
	Scuffing or scratches on the surface of piston skirt	Scuffing or scratches on the surface of piston skirt		
	The piston and ring groove are over worn	Excessive fitting clearance between the piston and the cylinder.	The engine starts hard or fails to start. Insufficient engine output; Thick blue and white fume form the exhaust muffler pipe.	Replace the piston
	The piston pin hole is over worn	Excessive fitting clearance between the piston ring and the hole.	Striking sound of the piston pin and of the cylinder.	
Crank pin	The crank pin is over worn.	Radial and axes gap of the connecting rod big end is too large	Striking sound of the big-end bearing; Striking sound of the cylinder	Replace the crankshaft connecting rod
Bearing	The big-end needle bearing is over worn	Radial and axes gap of the connecting rod big end is too large	Striking sound of the big-end bearing; and of the cylinder	Replace the crankshaft connecting rod
	The crankshaft bearing is over worn or		Abnormal sound during the crankshaft bearing	Replace the crankshaft
Piston ring set	The piston ring is fractured	The piston ring is fractured	The engine starts hard or fails to start. Insufficient	Replace the piston ring set

ZHEJIANG KAYO MOTOR CO., LTD.

	The piston ring is over worn	The piston ring opening gap or the side gap is too wide		
	Insufficient elasticity of piston ring	It is impossible to tight the piston ring and the cylinder properly		
	Improper fixing	The piston ring gap is not staggered	Thick blue and white fume form the exhaust muffler	Refixing the piston ring set
Piston pin	The piston pin is over worn	The fitting clearance between the piston pin and the hole is too wide	Striking sound of the piston pin and of the cylinder.	Replace the piston pin.
Connecting rod	The connecting rod small-end hole is over worn.	The fitting clearance between the piston pin and the small-end is too wide.	Striking sound of the piston and of the cylinder.	Replace the connecting rod
	The connecting rod is crooked or twisted.	The connecting rod is crooked or twisted.	Striking sound of the cylinder.	Replace the connecting rod.
	The big-end hole is over worn	Radial and axes gap of the connecting rod big end is too large	Striking sound of the big-end bearing and of the cylinder.	Replace the connecting rod
Timing sprocket	The gear is over worn of damage		Abnormal sound during sprocket driving	Replace the timing sprocket

6.5 Maintenance of Mechanism

6.5.1 Disassemble, assemble and maintain valve mechanism

Remove rocker arm shaft

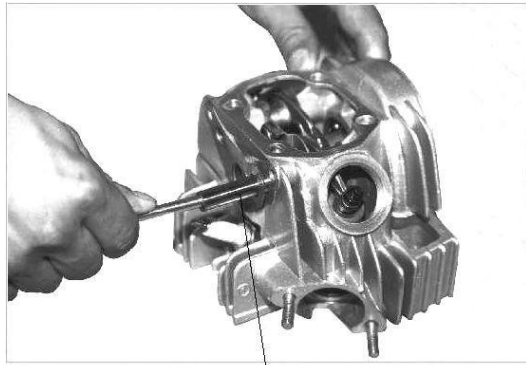

rocker arm shaft

Remove the rocker arm of inlet/exhaust valve and check the state.

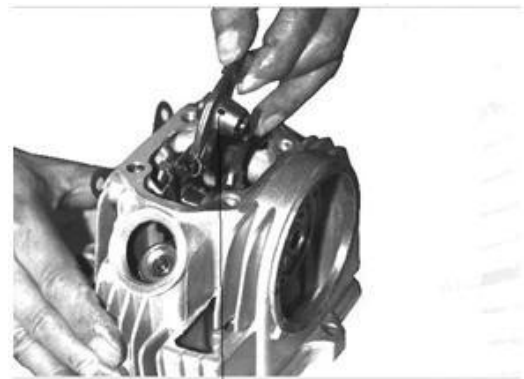

rocker arm

Remove the timing cam, rocker arm , rocker arm shaft to inspect for worn. Replace if necessary.

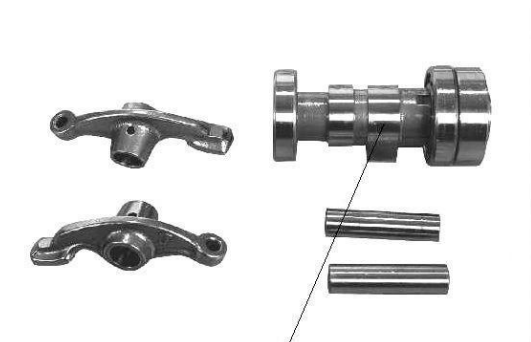

timing cam

Remove the circlip of inlet and exhaust valve. Remove inlet valve stem and exhaust valve stem take care and don't miss the valve clip.

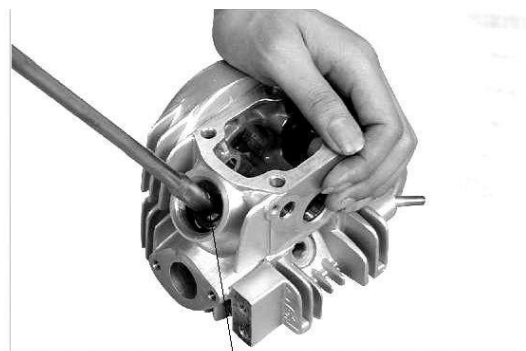

valve spring

Valve spring

Measure length of valve spring to check whether the spring is damaged or worn. Replace if necessary.

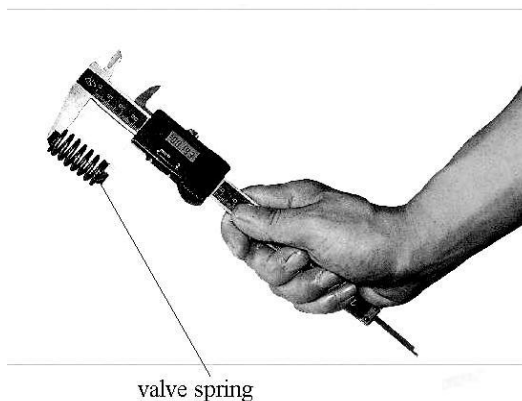

Remove the spring of inlet and exhaust valve to inspect for wear and damage.

Note: when assemble the valve spring, make sure its dense end downward.

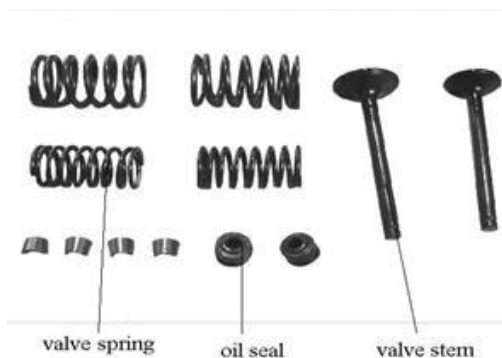

Check the external diameter of valve stem using a vernier caliper. Replace the valve stem if the valve is beyond the maintenance limit valve.

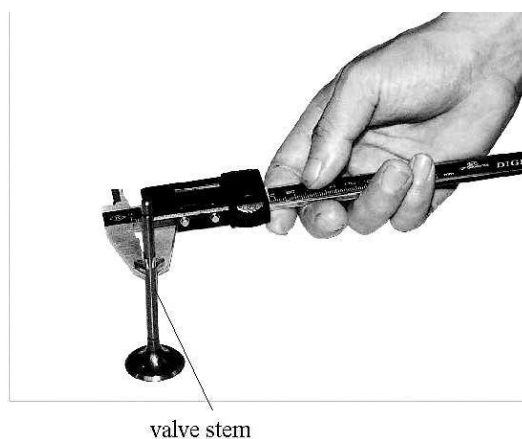

Measure the width of valve contact surface to check whether the contact surface is rough or abnormal. Replace the valve stem if the valve is large than 1.5mm.

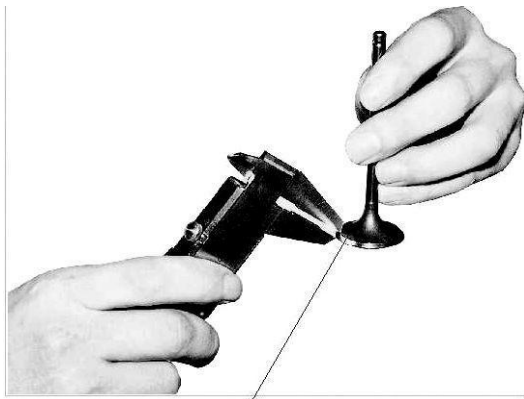

valve contact surface

Check whether the valve stem is distorted. Replace if necessary.

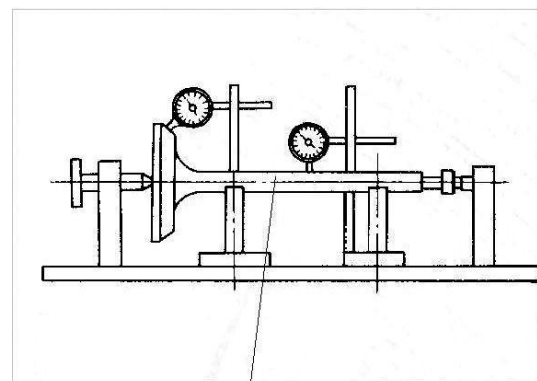

valve stem

Inspect the timing camshaft bearing for wear and check the state of camshaft. Replace if necessary.

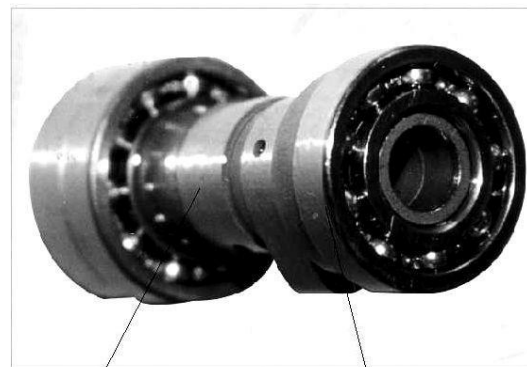

camshaft

camshaft bearing

Check the gap of rocker arm shaft and rocker arm. Replace the rocker arm shaft and rocker arm if the gap is large.

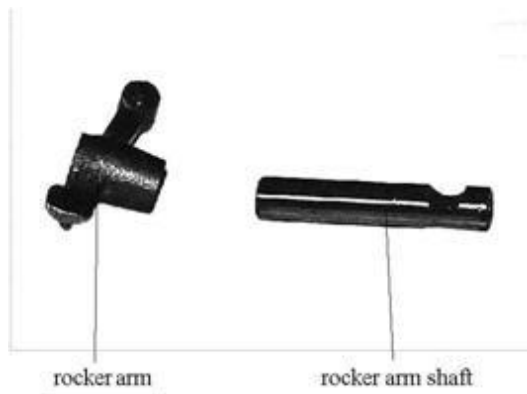

Check the external diameter of rocker arm using a micrometer. Replace the rocker arm shaft if the valve is beyond the maintenance limit valve.

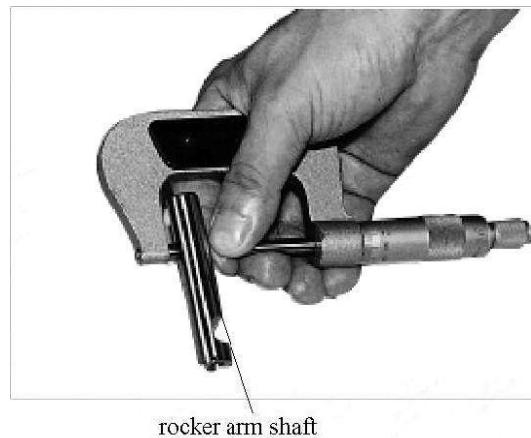

Remove the guide wheel of timing chain to inspect for wear and damage. Replace if necessary.

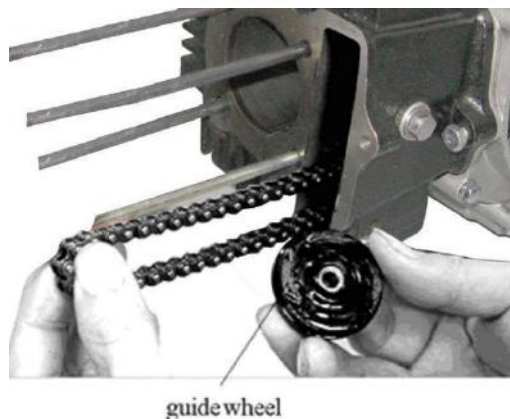

Remove the fixing bolt of timing tensioner and check the state. Replace if worn or if reuse is questionable.

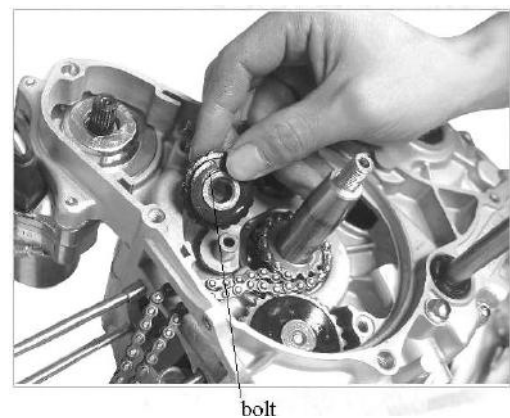

ZHEJIANG KAYO MOTOR CO., LTD.

Remove the timing tensioner arm to inspect for wear and damage. Replace if necessary.



timing tensioner

Remove the oil tube and spring and check the state. Replace if necessary.

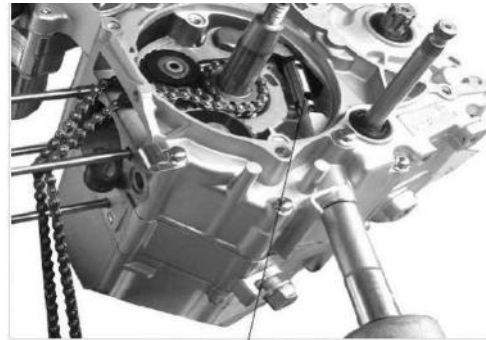

oil tube

Remove the small timing chain and check the state. Replace if necessary.

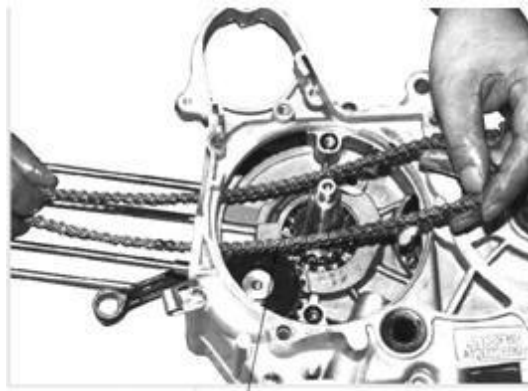

Adjust valve clearance as follows; Remove the valve cap and check the condition.



Valve cap

ZHEJIANG KAYO MOTOR CO., LTD.

Adjust valve clearance of front cylinder. Turn magnetic rotor counterclockwise to make piston locate at top dead center and make T mark aimed to the mark of left crankcase cover.

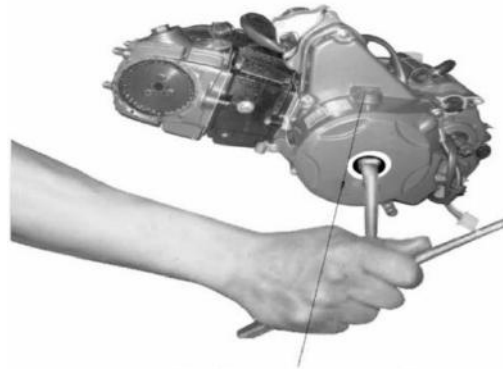

left cover mark

Check whether the O-mark on cam sprocket is aimed to the gap of cylinder head. Readjust if necessary.

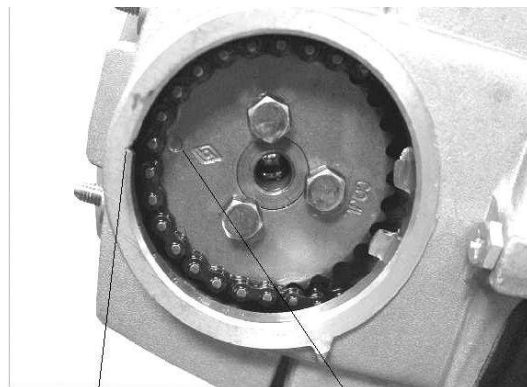

cylinder head mark

O mark

Set the valve clearance of rear cylinder to 0.05mm~0.06mm.

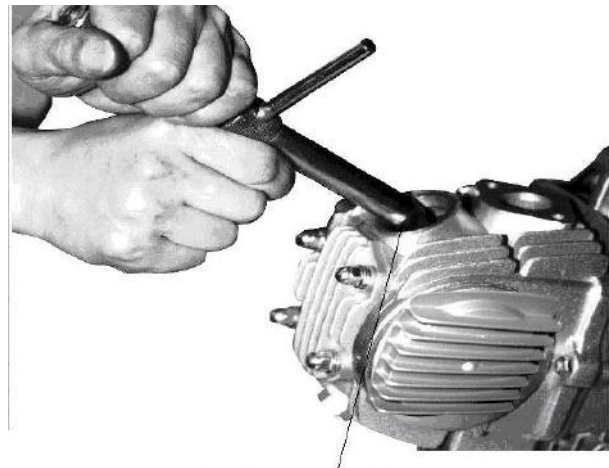

valve clearance adjustment

For the troubleshooting of engine distribution mechanism, please refer to the following table

Maintenance of Distribution Mechanism

Descriptions	Damage form	Trouble	Cause	Correction
Valve oil seal	The edge of valve oil seal is worn, age or		Thick blue and white fume form the exhaust muffler pipe.	Replace complete set of valve oil seal
	The cam is cover worn		Insufficient engine output	Replace the

ZHEJIANG KAYO MOTOR CO., LTD.

	The bearing of the camshaft is over worn or damaged	The axial or radial clearance of the bearing is too wide. Ineffective bearing swiveling or abnormal sound during swiveling.	Abnormal sound heard during camshaft transmission.	Replace the camshaft
Rocker arm	The working surface is scratched or over worn.		Valve striking sound	Replace the rocker arm
	The rocker arm shaft hole is over worn	Big gap between the rocker arm and rocker	Valve striking sound	Replace the rocker arm
	The rocker arm shaft is over worn	Big gap between the rocker arm and rocker	Valve striking sound	Replace the rocker arm shaft
Valve	The valve clearance is too small	The valve is impossible to close completely	The engine starts hard or fails to start. Insufficient engine output; Engine speed changes during idle run.	Readjust the valve clearance to 0.05~0.06mm
	The valve clearance is too big		Valve striking sound	Readjust the valve clearance to 0.05~0.06mm
	Carbon deposit on working surface	It is impossible to fit the valve and the valve seat tightly.	The engine starts hard or fails to start. Insufficient engine output; Engine speed changes during idle run.	Remove the carbon deposit
	The working surface is over worn or has pits, pock marks, ablation or damage.	It is impossible to fit the valve and the valve seat tightly.	The engine starts hard or fails to start. Insufficient engine output; Engine speed changes during idle run.	Replace the valve

	The valve stem is over worn	The fitting clearance between the valve stem and the valve guide is too wide.	Sound of valve leakage, Thick blue and white fume form the exhaust muffler pipe.	Replace the valve
	The valve stem is deformed	It is impossible to close the valve completely.	The engine starts hard or fails to star	Replace the valve
Valve spring	The spring is ineffective or fractured	It is impossible to fit the valve and the valve seat tightly.	The engine starts hard or fails to star. Sound of the cylinder head.	Replace the valve spring

6.6 Disassemble, assemble and maintain carburetor (it's not adjustable in EPA state)

Dismantle the fixing bolt of carburetor and circlip of air cleaner. Remove the carburetor .Remove and clean throttle cap.



Clean the carburetor as follows: Remove the dirt and clean inner oil way.Dismantle the fixing bolt of float chamber cap.



fixing bolt

Remove the float chamber cap. Remove the water and debris in the cap if necessary. Check the state of seal ring and replace if it is aging



Remove the float needle valve to inspect for wear and damage. Replace if necessary.



float needle valve

Remove the throttle and oil needle and check the condition replace if necessary.



throttle

oil needle

Check the state of float case and replace as necessary. Adjust the height of float case by moving the float up or down.



float case

Take out the main jet to check whether the jet hole is clogged. Clean if necessary.

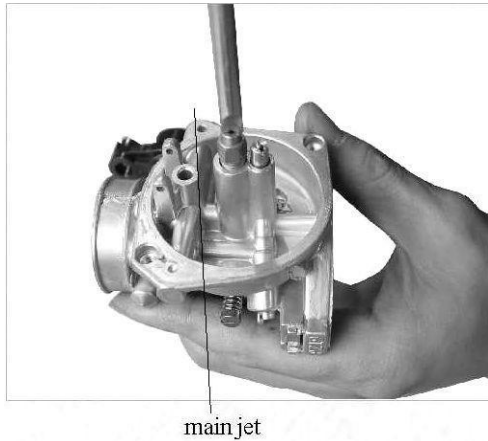

Remove the main nozzle to check whether small hole is clogged. Clean with compressed air if necessary.



Remove the idle jet and check for plugged. Clean the jet with compressed air if necessary.

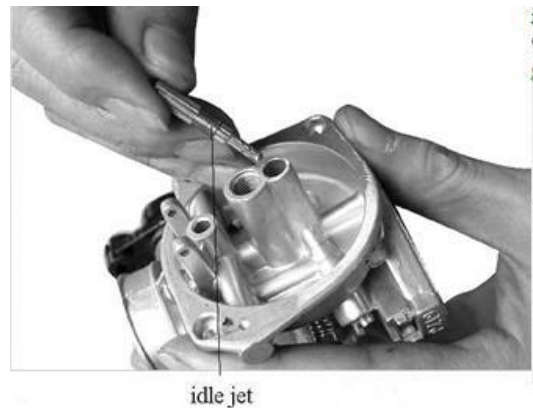

Dismantle the mixture adjustment screw and inspect for worn. Replace if necessary. Adjust mixture screw of carburetor as the following. Standard: Tighten mixture screw, and turn it one And a half turns clockwise.

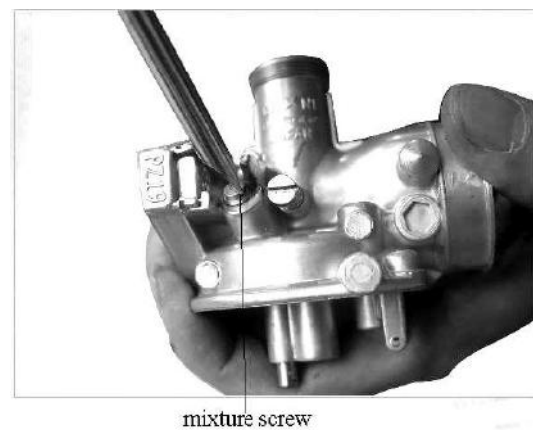

ZHEJIANG KAYO MOTOR CO., LTD.

Measure height of float case to check whether it is distorted or there is oil in the case. If height is incorrect, which indicates carburetor leaks or the oil supply is insufficient.

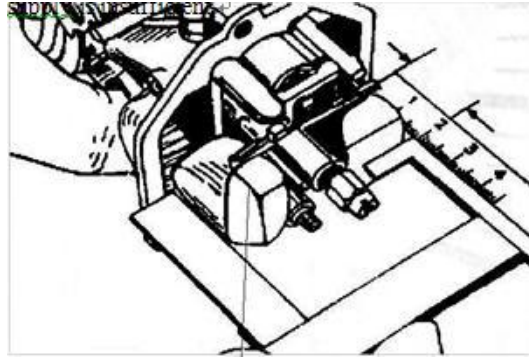

Adjust the oil needle to the third tier. If the clip rises, concentration of mixture becomes dilute and if falls it becomes thick.

6.7 Maintenance of Intake/Exhaust System

6.7.1 Disassemble, assemble and maintain intake system

Remove the air filter snap ring, then take air filter out.



Remove the air filter to remove dust from the housing and remove the air filter for cleaning. The element of air filter is paper, it can't clean, so replace a new one.

For the troubleshooting of the air cleaner, please refer to the following table.

Description	Damage form	Trouble	Cause	Correction
-------------	-------------	---------	-------	------------

ZHEJIANG KAYO MOTOR CO., LTD.

Air filter	Too much dust on the filter core	Engine start difficulty or starting failure. Insufficient engine output; The engine performed poorly at idle. Excessive fuel consumption. Exhaust muffler pipe smoke is strong (black).	The engine starts hard or fails to start. Insufficient engine output; poor performance of engine during idle run. Excessive fuel consumption. The exhaust muffler pipe fumes	Clean the filter element
	The filter core is fractured or chapped.		Engine air suction noise is too loud	Replace the filter element

6.8 Disassemble, assemble and maintain exhaust system

Dismantle lock nut of muffler

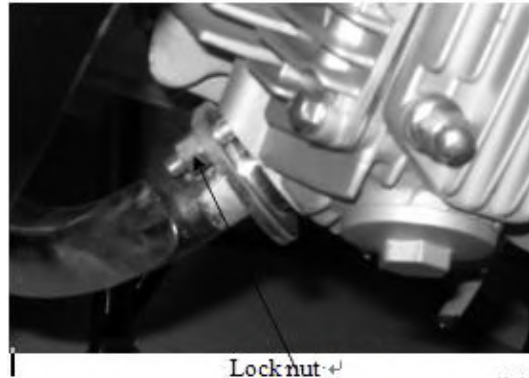

Dismantle suspension bolt of muffler to check whether the suspension support is damaged. Repair or or replace if necessary.



Remove the muffler to inspect for broken and damage. Replace or repair if necessary.



Remove the washer of muffler to inspect for damage. Replace if necessary.



Washer

For the troubleshooting or the exhaust muffler, please refer to the following table.

Description	Damage form	Trouble	Cause	Correction
Exhaust pipe gasket	The gasket is broken	Exhaust pipe leakage	Engine exhaust noise is too loud.	Replace exhaust pipe gasket
Exhaust muffler	enclosure broken	The muffler enclosure is broken	Engine exhaust noise is too loud.	Replace exhaust muffler.

6.9 Disassemble, assemble maintain the environmental protection

Maintenance of Exhaust Muffler

valve

Inspect the lock nut for tightness and tighten as necessary.



Inspect the connecting circlip of air pump for tightness. Tighten if necessary.



Dismantle the fixing bolt of air pump and check the state of air pump. Replace the air pump if it is worn or if reuse is questionable.



Remove the secondary inlet air cleaner and inspect for wear and damage. Clean and replace if necessary.

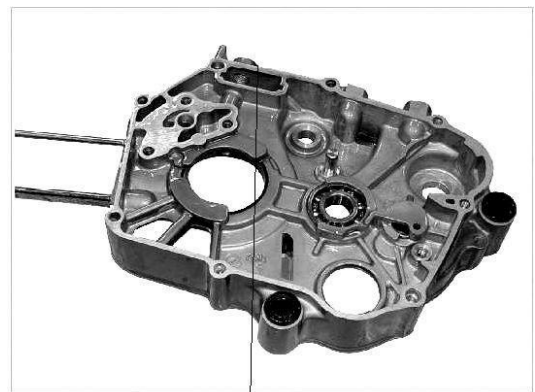

air cleaner

For the troubleshooting of environment protection valve, please refer to the following table.

Maintenance of environment protection valve

Parts	Damage form	Trouble	Cause	Correction
air cleaner	air cleaner damaged or plugged	defective air cleaner	Emission fails to meet	Replace
connecting hose	connecting hose get loose	noise is too loud	Emission fails to meet	Replace
Gasket	large noise from	air leaks form secondary inlet	Emission fails to meet	Replace
muffler exhaust	too much carbon deposit on muffler	Poor combustion	Emission fails to meet	Remove and clean

6.10 Disassemble, assemble, maintain and manage motor starter

Remove the fixing bolt from left crankcase cover.



bolt

Dismount gear indicator fixing bolt, remove gear indicator to check the wear or damage condition, replace it if necessary.



gear indicator

Remove left crankcase cover



left crankcase cover

Remove gasket to check it's condition. If the gasket is wearied or reusable, please replace it.



gasket

Remove fixing bolts of stator and trigger .



fixing bolt



fixing bolt



stator

Check stator status with multimeter. If wear and tear or re-use problems, please replace the new accessories



stator

Remove rotor fixing nut



fixing nut

Remove rotor by special tools



special tool

Remove rotor to check magnetism, necessary replace it if it.



rotor

Remove overrunning clutch fixing bolt.

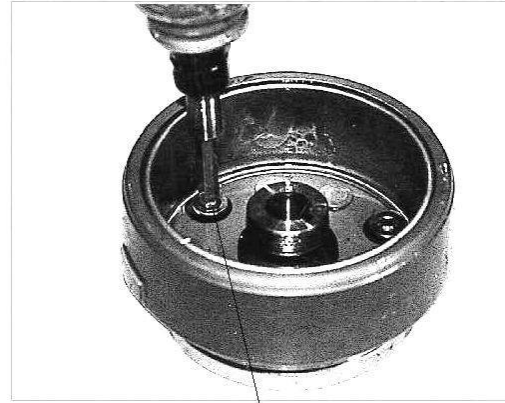

fixing bolt

Remove clutch to check the weary and damage condition of clutch seat, pulley and spring. If it necessary replace it.

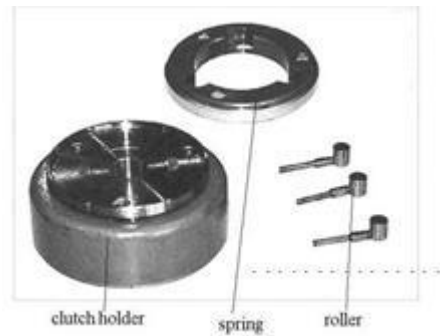

clutch holder

spring

roller

Check the weary damage condition of drive sprocket and transmission gear. If it necessary replace it.

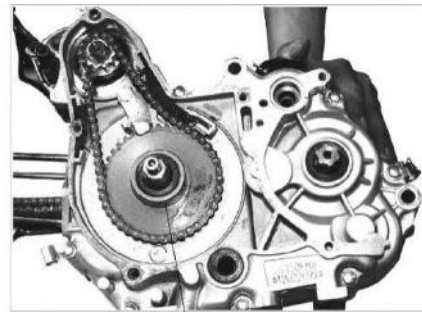

driving gear

Disassemble start sprocket press board



pressing plate

Dismount tension band of clutch and check the condition. If it wearied or reused, replace it.

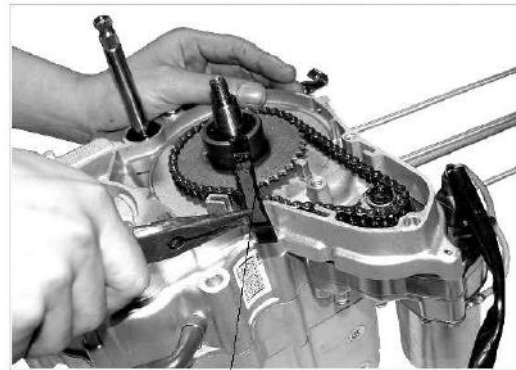

tension strip

Remove the snap ring from start motor sprocket.

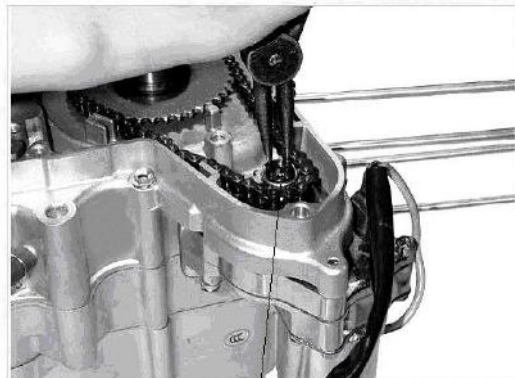

sprocket circlip

Disassemble the drive sprocket and chain.

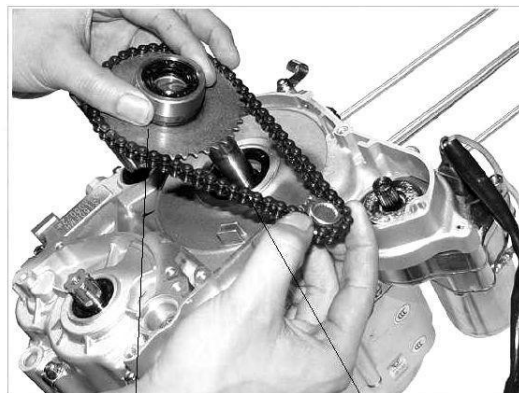

driving sprocket

driving chain

Dismount the fixing bolt of start motor.

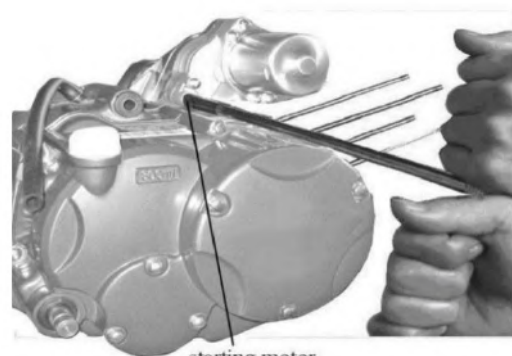

starting motor

Disassemble start motor.

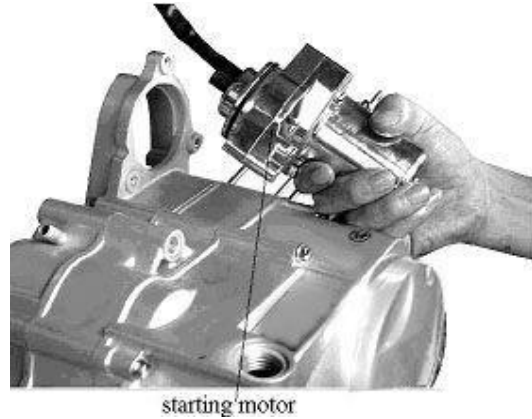

starting motor

Check the start motor winding, if it necessary replace it.



starting motor

Disassemble the oil separation disc and check the condition, if it necessary replace it.

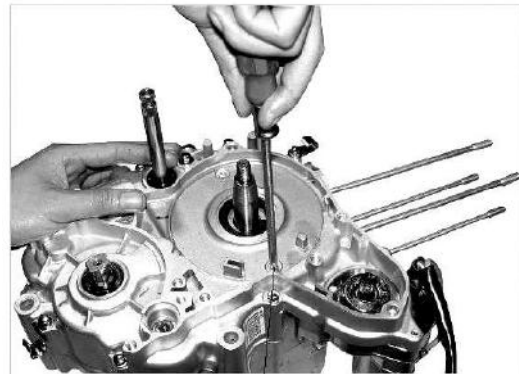

fixing
bolt

Check oil seal edges for wear.
Replace as necessary.

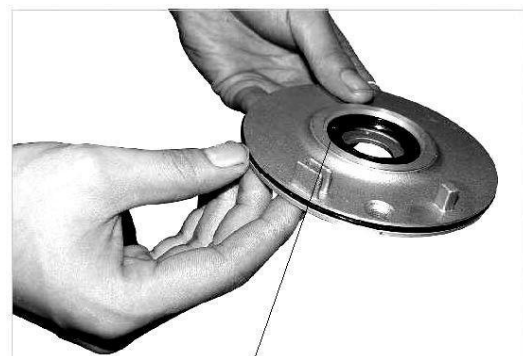

oil seal

ZHEJIANG KAYO MOTOR CO., LTD.

Remove the seal and check the oil ring condition, if it wearied, replace it.

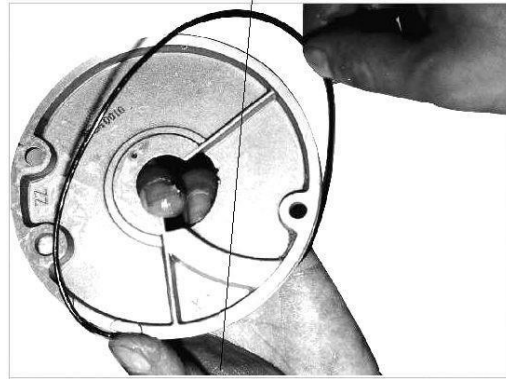

For troubleshooting of engine electric starter, please refer to the following table

Maintenance of Electric Starter

Description	Damage form	Trouble	Cause	Correction
Starter motor	Carbon brush is over worn. The carbon brush		Starter motor has insufficient rotation force or it is out of	Replace carbon brush
	fractured or has insufficient elastic force.		Starter motor has insufficient rotation force	Replace carbon brush spring
	Armature commutator surface is fouled		Starter motor has insufficient rotation force	Clean the commutator surface with gasoline or alcohol
	Armature commutator surface is spotted, burnt or damaged.		Starter motor has insufficient rotation force.	Polish the surface against the commutator with fine abrasive Paper. Make the cut on the mica Plate between each commutator Piece with broken saw bit 0.5~0.8mm deeper than the commutator surface. Remove the chip and Burr between each commutator.
Armature commutator surface is ablation or over worn.		Starter motor has insufficient rotation force or is out of work.	Replace starter motor	

Circuit diagram

